



TAYANA YACHTS

OWNER'S MANUAL TAYANA-48



STANDARD

CONTENT

I . INTRODUCTION.....	4
1.1 Introduction.....	4
1.2 Degree of dangers.....	6
1.3 Design category.....	7
1.4 Principal particulars.....	8
1.5 Propulsion system.....	9
1.6 Shaft & Propeller.....	13
1.7 Electrical system.....	17
1.8 Fuel system.....	25
1.9 Bilge & drain water system.....	29
1.10 Fresh water system.....	31
1.11 Toilet shower/sump/common drain system.....	35
1.12 Salt water system/ seacock and through-hull.....	38
1.13 Steering system.....	42
1.14 Sails & rigging.....	45
1.15 Safety equipment.....	48
II . MAINTENANCE.....	52
2.1 General hull maintenance.....	52
2.2 Gel coat.....	52
2.3 Fiberglass/Gel coat stains & scratches.....	53
2.4 Fiberglass/Gel coat special care for boats be moored.....	53
2.5 Bottom paint care.....	54
2.6 Plexiglas.....	54
2.7 The deck & deck fittings.....	55
2.8 Interior wood.....	56
2.9 Exterior vinyl care.....	56
2.10 Daily checks.....	59
2.11 Battery electrolyte.....	59
2.12 Corrosion protection.....	60
2.13 Mechanical.....	61

2.14	Propeller shaft.....	61
2.15	Propeller.....	62
2.16	Fresh water pump strainers.....	64
2.17	Shower drain pump.....	64
2.18	Boat Exterior.....	64
2.19	Cleaning of the fiberglass.....	65
2.20	Teak Decking.....	66
2.21	Anti-fouling & Marine growth.....	67
2.22	Care & clean of acrylic parts.....	68
2.23	Upholstery etc.....	69
2.24	Light fittings.....	71
2.25	Metal fittings.....	72
2.26	Cold water precautions.....	72
2.27	Appendices.....	73

III. OPERATING INSTRUCTION.....74

3.1	Useful hints before each journey.....	74
3.2	Pre-start checks.....	74
3.3	Starting the engine.....	75
3.4	Cold starting.....	76
3.5	After the engine have started.....	77
3.6	Running in.....	77
3.7	Maximum engine speed.....	77
3.8	Casting off.....	78
3.9	Docking.....	78
3.10	Shutting down.....	79
3.11	Safety equipment.....	79
3.12	Etiquette.....	81
3.13	Useful information.....	81
3.14	Instrument.....	82
3.15	Tachometer.....	82
3.16	Temperature gauge.....	83
3.17	Oil pressure gauge.....	83
3.18	Gear box oil pressure.....	83
3.19	Hour meter.....	83

3.20 Alarm system.....	84
3.21 Ammeter.....	84
3.22 Voltmeter.....	84
3.23 Troubles shooting.....	84
IV.ENVIRONMENT.....	106

INTRODUCTION

1.1 Introduction

Your TAYANA48 is built to a very high specification using the most modern, advanced and reliable materials and techniques. The hull is constructed in high-impact, multi-axial laminate fiberglass. All components and fittings have been chosen to the highest standards.

To enjoy your quality boat to the fullest it is important that you become thoroughly familiar with every aspect of its operation and care. This user handbook has been designed to provide you with all the information you may require. Always keep it in a handy place for ready reference.

This handbook is divided into sections covering everything and includes hints and tips on driving and safety, as well as how to take good care of your valuable investment.

Your TAYANA48 has been designed to give the highest standards seaworthiness and rugged durability. In order to preserve these qualities, it is important to follow the user care instructions, which have been prepared in order that all aspects of high performance, good looks and reliability might be maintained over the years.

With reasonable care and attention your TAYANA48 will give you many years of pleasure and safe boating. This owner's manual has therefore been specially prepared to guide you in keeping your boat in tiptop condition.

Note

This manual is intended to be a general guide to the maintenance and operation of this TAYANA48 and equipment installed. Most of the equipment supplied from other

manufacturers includes owner's or operator's manual. We urge that you read those manuals carefully.

The operation of this vessel or any sailboat can be dangerous if operated in an unsafe manner. This manual is not intended to be a substitute for training or experience in the safe operation of this vessel.

We urge each owner not familiar and experienced in the safe operation of motorized vessel to seek training from an appropriate organization.

1.2 DEGREE OF DANGERS

In this manual and on board the craft, warning sign are placed at where special precaution has to be taken. Those warning sign denotes the following degree of danger as the following.

DANGER!

Denotes an extreme intrinsic hazard exists which would result in high probability of death or irreparable injury if proper precautions are not taken.

WARNING!

Denotes a hazard exists which can result in injury or death if proper precaution is not taken.

CAUTION!

Denotes a reminder of safety practices or directs attention to unsafe practices which could result in personal injury or damage to the craft of components.

1.3 DESIGN CATEGORY

This vessel is design to Design Category A according to CE/ISO requirement.

Category A – “Ocean” :

This craft is designed for operate in winds that may exceed wind force 8 (Beaufort scale) and in significant wave heights of 4 m and above (see Note 1 below), and is largely self-sufficient. Abnormal conditions such as hurricanes are excluded. Such conditions may be encountered on extended voyages, for example across oceans, or inshore when unsheltered from the wind and waves for several hundred nautical miles.

CAUTION!

Please keep this manual in a secure place, and hand it over to the new owner when you sell the craft.

1.4 PRINCIPAL PARTICULARS

TAYANA48-DECK SALOON

Maximum Length	Lmax	14.60	m
Length of the Waterline	LWL	12.63	m
Maximum Beam	Bmax	4.40	m
Maximum Hull Depth	Dmax	3.04	m
Draft		1.87	.m
Ballast		5.3	t
Displacement		15.9	t
Sail Area		1,048	sq.ft.
Fuel Capacity	560 (145)		liters (gal)
Fresh Water Capacity	964 (250)		liters (gal)
Holding Tank	82 (22)		liters (gal)
Engine Model	YANMAR-4JH4-HTE		
Engine Power	73.6 KW (100 HP)	3800rpm	
Gear Box Model	KANZAKI-KM4A1	2.63:1	
Gen Set Model	WESTERBEKE 7.6BTD		
Gen Set Kw		5.7KW/50Hz	
AC Voltage	220 V		
DC Voltage	12 VDC		
Battery	225Amp/hr x 5	160Amp/hr x 1	
Design Category	A		
Maximum Number of People	8	Person	
Maximum Loaded	3.5	t	

1.5 PROPULSION SYSTEM

The power generated by the engine is transmitted to the propellers via the transmission, shaft coupling and propeller shaft assembly. The propeller shaft is supported and aligned with the engine by a through-hull shaft log and an outside strut.

Your propulsion system is manufactured from high quality materials. Your system's performance and life span very much depends on the care you give it. To maintain its reliability and ensure the long life for all the components, your system demands your careful attention, treatment and a consistent program of preventive maintenance.

Main Engine

This manual does not contain detail information about main engines. Necessary information concerning the main engine is in the "Engine Owner's Manual". It is important that you read the "Engine Owner's Manual" carefully for maintenance and warrant.

Your boat is powered by one diesel engine. All the operation, specification and maintenance information is contained in the engine owner's manual. Please familiarize yourself with it. The engine is the heart of your boat and following manufacturer's recommendations will provide you with continued boating pleasure.

CAUTION!

Totally familiar with the safe and proper service procedure. Always consult qualified mechanics for repair and service of the engines.

NOTE :

It is important that you :

- (1) Check the engine lubrication oil level coolant level and air cleaner before you start the engine.



Gear Oil Checking Level

- (2) Check the transmission lubrication oil level according to the engine operation manual.



Gear Oil Checking Level

Cooling System

Each engine is cooled by salt water entering the boat through a sea-cock. The water enters the engine through the engine water jacket and returned to the sea through the exhaust system.

The cooling system used the incoming salt water to cool a

secondary closed cooling system. The salt water flows through an engine, mounted heat exchanger, cools the closed system coolant and is returned to the sea via the exhaust system.



Sea Water Inlet for Engine

!

THE COOLING SYSTEM STARTS AT THE COOLING WATER SEA COCK, WHICH CAN BE SHUT OFF IF REQUIRED.

MAKE SURE THE SEACOCKS ARE OPEN BEFORE STARTING THE ENGINE. THE ABSENCE OF COOLING WATER WILL CAUSE THE ENGINE TO OVERHEAT AND CAUSE IRREPARABLE DAMAGE.

Alarm System

The engine and transmission are protected by an independent alarm system consisting of an alarm bell mounted on control console.

The alarm system was designed to warn you audibly or visibly in case any of the following possible damaging conditions exist:

- (1) Engine temperature (water temperature) exceeds specified limit.
- (2) Engine oil pressure drops below specified limit.

(3) Transmission oil pressure exceeds specified limit.

(4) Exhaust temperature exceeds a set up limit.

If any of these occurs the alarm bell will sound and the related port or starboard alarm lamp will illuminated.

!

IF THE ENGINE ALARM BELL SOUND AND ANY ENGINE ALARM LIGHT ILLUMINATES INDICATING AN ENGINE OR TRANSMISSION PROBLEM, YOU SHOULD IMMEDIATELY :

(1) THROTTLE THE ENGINE BACK TO IDLE

(2) SHIFT THE ENGINE INTO NEUTRAL

(3) SHUT DOWN THE ENGINE

To test the alarm system, turn the ignition switch to the "ON" position.

Depending upon the engine, the alarm may sound immediately or after a few seconds delay.

Transmission

Through a series of gears the transmission transmits the motive force of the engine to the propeller. The transmission has one forward and one reverse speed. All the operation, specification and maintenance information is contained in the "**KANZAKI-KM4A1** Operating Manual".

This manual dose not contains detail information about transmission gear box. Necessary information concerning the main engine is in the "Transmission Gear Box Owner's Manual". It is important that you read the "Transmission Gear Box Manual" carefully for maintenance and warrant.

CAUTION!

Always check oil level in the transmission according to the Transmission Gear Box Owner's Manual and use the correct type of oil as specified in the manual.

1.6 Shaft & Propeller

Shaft Assembly

Shafts are selected for your TAYANA48-DECK SALON. This assembly makes it possible for the shaft to penetrate the hull bottom without allowing water to enter around the joint. The shaft coupling is the connecting point between the engine and the shaft assembly.

TAYANA48-DECK SALON is fitted with flexible coupling to ensure very smooth and quiet propulsion.

For details of shaft system, please refer to attach DWG. At appendices.

Although the shaft is properly aligned and couple at the factory, Propeller shaft alignment must be again check by your dealer or qualified mechanic during pre-delivery service. Periodic checks of shaft alignment should be made especially if noise or vibration occurs.

CAUTION!

Misalignment can cause damage to shaft bearing, shaft, struts and the engine transmission.

Strut and Bearing

The propeller shaft is supported on the outside of the hull by a strut. The strut with water lubrication plastic bearing allows free rotation of the propeller shaft.

Seasonal inspection of each strut should be made to ensure no damage and the strut bearing is not worn excessively.



The propellers installed on your boat are selected because their diameter and pitch provide the optimum speed and performance under average conditions of load. Propeller selection must be based on upon the ability of the engine to turn the propeller and achieve the manufacturer's recommended RPM at full throttle.

CAUTION!

Frequent inspection of the propeller is suggested, damage to one or more of the blades, though slight, can be a source of annoying vibration.

NOTE :

Variations from average loading, bottom condition and engine condition could call for a propeller change to achieve the performance desired.

**! IMPROPER PROPELLER SELECTION AND INSTALLATION
COULD RESULT IN LOSS OF THE PROPELLER OR
EXCESSIVE STRESS ON THE POWER TRAIN LEADING TO
POWER TRAIN FAILURE. PLEASE CONSULT AND EMPLOY
A SKILLED TECHNICIAN WHEN CONTEMPLATING A
CHANGE.**

Propulsion System – Shaft Seal



PYI Drip less shaft seal

Slight moisture from the seal is common. Please carefully read the information sheet on the seals pertaining to adjustment.

CAUTION!

Never spray lubricants on the drip less shaft assembly black components. Damage will occur.

CAUTION!

**The following document will be ship loosed by your
boat
Regarding the engine layout & operation PLS refer
to
--YANMAR ENGINE OPERATION MANUAL--**

YANMAR MARINE INTERNATIONAL B.V.
www.yanmarmarine.com

JH Turbo-Series



Operation Manual (EN)



- Operation Manual (EN)
- Bedienungsanleitung (D)
- Betjeningsmanual (DK)
- Manual de instrucciones (E)
- Manuel d'utilisation (F)
- Käyttöohje (FIN)
- Εγχειρίδιο λειτουργίας (GR)
- Manuale d'istruzioni (I)
- Driftshåndbok (N)
- Bedieningshandleiding (NL)
- Manual de instruções (P)
- Driftsinstruktion (S)

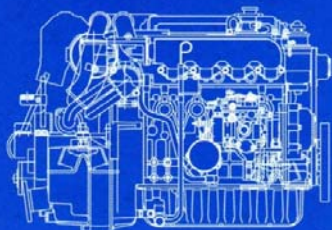

YANMAR MARINE INTERNATIONAL B.V.

49901-20280

1.7 ELECTRICAL SYSTEM

General

The TAYANA48 electric system contain a 12 volt DC circuit serviced by batteries and a 220 volt AC system serviced by either the on board generators or shore support system, for use while facilities exists.

5.7 kW generators are fitted as standard. Refer to the manufacturer's handbooks for details of operation and maintenance.

All installations and cabling are clearly labeled for ease of maintenance. The wiring circuits are split into several looms, bundled together where appropriate, depending on their route through the vessel and their origin and destination. Each cable in each loom is labeled at end with shrink fit containing a code. Please refer to the wire number codes.

D.C. Control

The basic service and starting circuit is 12 volt DC. The electronic equipments are supplied by 12 volt DC and with negative ground. Details of electric circuits can be found on the schematic enclosed with this manual.

On the main DC control panel are switches linked to the circuit breakers controlling power supply to the systems including many the vessel's domestic service, the navigation instruments, lights, gray water and holding tanks' discharge pumps.

Batteries System

There are five 225 AH and one 160AH batteries. The 160 AH battery is dedicated to start the main engine, one of batteries are dedicated to start the generator, two of batteries are dedicated to start the bow thruster and the remaining two to house service.

Your 12V batteries system is powered by marine grade 12 volt, 225-AMP-hour battery. Attention should be given to maintaining the proper level of distilled water. Do not overfill. The batteries location can be found in the salon arrangement layout.

The batteries are provided with a tie-down to prevent tipping over at extreme angles of heel. Be sure these tie-downs are fastened securely.

With proper care, the battery installed will provide long and satisfactory service. Proper care is not difficult, if a few basic points are kept in mind.

CAUTION!

In order to prevent a short circuit between battery terminals, do not store conductive objects near the batteries (e.g. metal tools,...) .

WARNING!

The electrolyte in a battery is a solution of sulfuric acid. If any should enter the eyes, rinse immediately with large amounts of fresh water and seek medical attention. Electrolyte spilled on skin should be rinsed well with fresh water, also. Even a small

amount of electrolyte spilled on clothing will destroy the clothing.

Electrolyte Level

The electrolyte level in a battery should never be allowed to fall low enough to expose the plates. This not only results in a loss of battery capacity while the battery is low, but also causes hardening of the active material on the battery plates. This will result in a permanent loss of battery capacity.

CAUTION!

Use only pure distilled water to replenish electrolyte levels. The water from many city water supply systems is unsatisfactory for battery use.

Discharged State

Leaving a battery in a discharged state for any length of time can also result in a permanent loss of capacity for the battery. Doing so, in cold weather, can destroy the battery, since it will freeze at relatively low temperatures.

Clean Connections

Keep battery connections clean and tight. A cupful of strong baking soda solution and a toothbrush will clean corrosion from the terminals and neutralize any spilled acid. Do not allow any of the solution to enter the battery cells. A coating of petroleum jelly on the battery terminals will inhibit corrosion.

Battery Isolator Switch

There are isolator switches for each bank of batteries. Tie switches are installed between engine starting and generator starting batteries.

Normally the main engine and generator will start by individual battery. In case the battery is low, turn on the parallel switch and parallel both banks of batteries. A legend is located next to the switches for your convenience.

!

DO NOT TURN OFF EITHER ISOLATOR SWITCH WHILE ENGINES ARE RUNNING

Battery Select Switch

! TO AVOID SERIOUS DAMAGE TO THE ALTERNATORS OR LOSS OF CONTROL CIRCUIT FUNCTIONS INCLUDING SHUTDOWN, DO NOT TURN THE BATTERIES MASTER DISCONNECT SWITCH TO THE “OFF” POSITION WHILE THE ENGINE IS RUNNING.

WARNING!

Never work on a live electric fitting.

WARNING!

Never tamper with an electric fitting. Call in a technician qualified in marine electricity. The batteries must be carefully and safely stowed.

WARNING!

Never alter the specifications of the breakers, which protect against overload.

WARNING!

Never fit or replace the electric materials or appliances with components, which exceed the system amperage.

AC 220V Electric System

The Vessel is fitted with a 220V/50Hz system. We advise you to follow these steps in order to avoid the risk of electric shock and fire.

WARNING!

Do not work on a live fitting.

WARNING!

Connect the boat/shore supply cable to the boat before you plug it into the shore supply socket with the breaker off. Turn the breaker on last.

WARNING!

Do not immerse the boat/shore cable socket. Turn off the shore supply switch on board before you plug in or unplug the boat/shore cable.

WARNING!

Do not tamper with the connections of the boat/shore supply cable. Use only compatible connections.

WARNING!

Never swim in a marina around boats connected to shore power. If it's necessary for maintenance unplug the boat being worked on and surrounding boats.

Generator

The generator is fitted in the vessel. Read instruction supplied from the generator manufacturer will explain its operation. This manual doesn't contain detail information about generator. Necessary information concerning the generator is in the " Generator Owner's Manual ". It is important that you read the " Generator Owner's Manual " carefully for maintenance and warranty.

CAUTION!

Do not attempt to service any generator component without being totally familiar with the safe and proper service procedure. Always consult qualified person for repair and service of the engines.

CAUTION!

Do not operate the generator with water intake valve closed. Overheating will result. Also, be sure the water filter strainer in the intake line is kept clear of dirt and debris.

CAUTION!

Be sure to run the engine room blower 5 minutes before starting the generator.

DANGER!

The exhaust fume from generator units contains carbon monoxide with potentially dangerous. Avoid inhaling these fumes.



DC EQUIPMENT PANEL

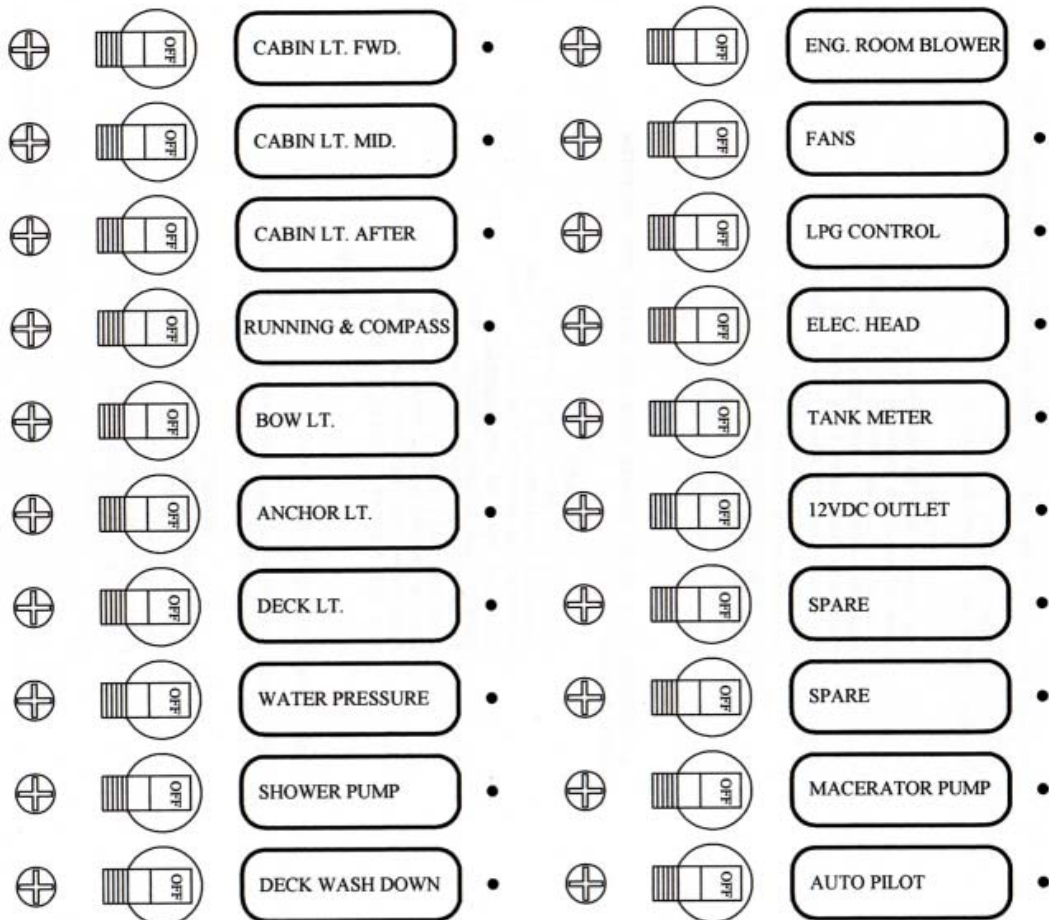

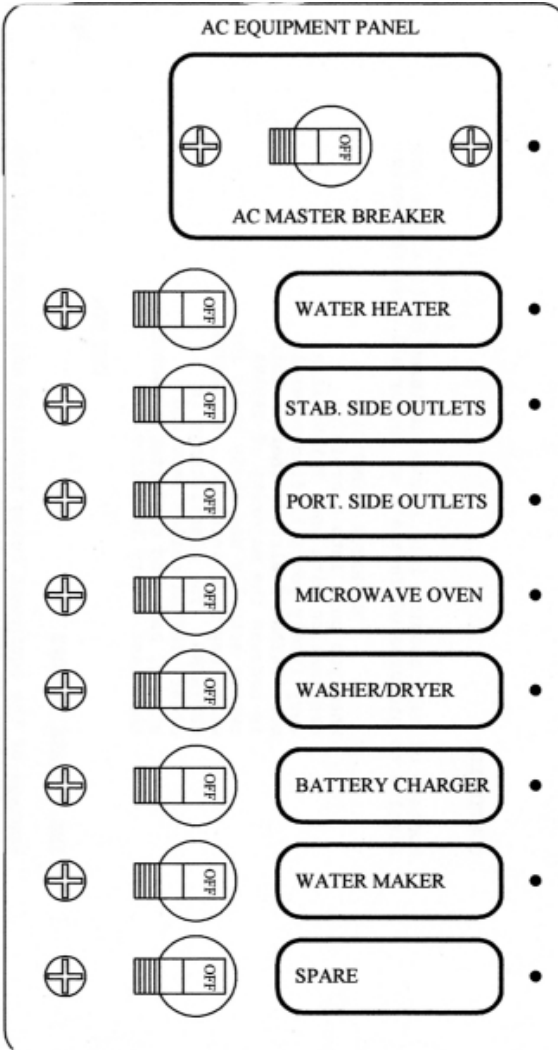
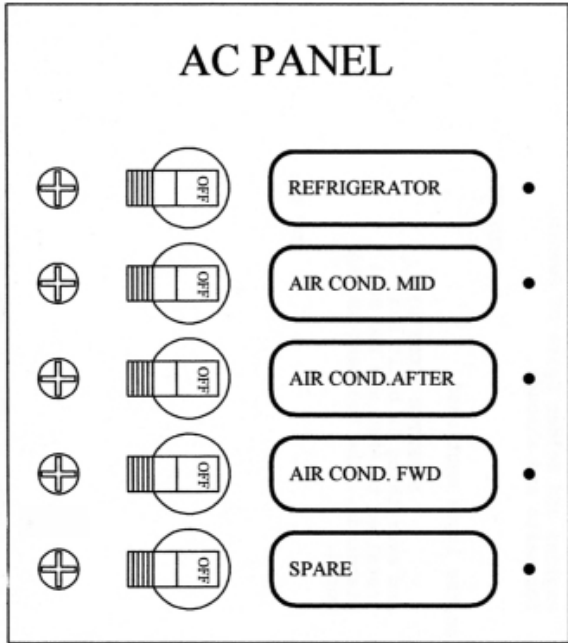

1.8 FUEL SYSTEM

System Description

Diesel Fuel, to power the main engine and generator, is stored in one tank in the after cabin under berth.

The capacity of tank is **560 (145) liters (gal)**

*** Function of the heel, the capacity can not be usable at 100%. A reserve of 20% should be kept.**

Your fuel system consists of:

- (1) One fuel tank
- (2) Fuel Select Valves
- (3) Fuel Lines

Fuel Filling

Extinguish all open flames aboard the yacht before opening the fuel inlet cap. No person should be smoking and all electrical circuit including the main electrical should be turn off. The fuel hose nozzle must be touching the metal deck plate to ground static electricity. After completion of the refueling, close the inlet cap tightly and wash down any spills with fresh water. Open all hatch and operate the blower for at least five minutes.

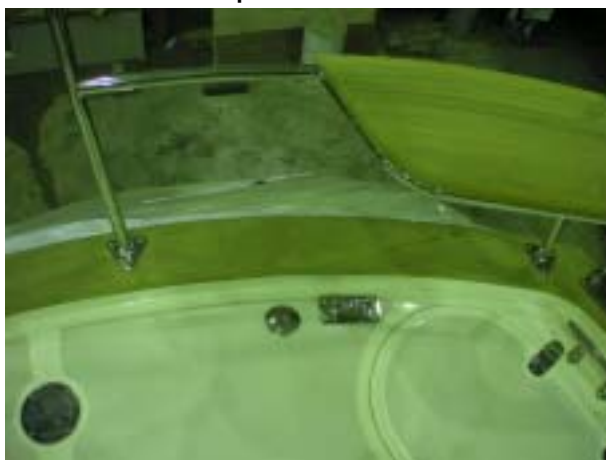

STERN FUEL INLET

Your TAYANA 48DS has one fuel filler. It is flush mounted deck plates, located on stern of starboard side.

NOTE :

When you fill the fuel tank, check carefully to ensure that fuel does overflow through the vent when full. Only use the clean, high quality diesel fuels that are specified in your engine manual. Diesel fuel must be clean and free from contamination. Fuel tank and stored fuel must be inspected regularly for dirt, water and bacteria

Fuel Filters

Each main engine and generator supplied has fuel filter. All of the filters function primarily as water separator trapping moisture that may enter or condense in the fuel tanks.

They should be checked regularly in accordance with the Maintenance Schedule.

NOTE :

Replacement of the filter will require bleeding of the fuel system to vent air, which will enter when the cartridge is removed.



Fuel Filters

The fuel system schematic drawing is shown bellow. Fuel lines are in yellow color code.

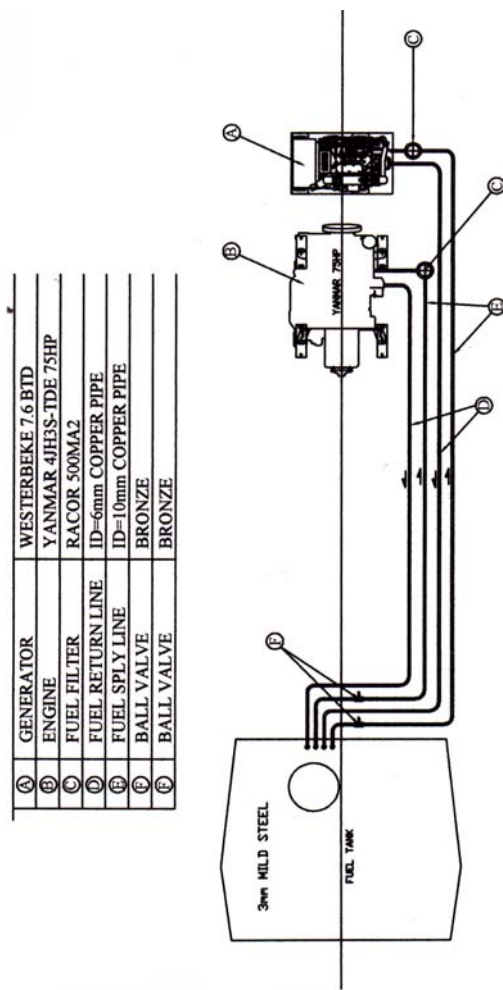

Schematic of Fuel System

Fuel Return System

The fuel pump on a diesel engine supplies more fuel than is actually required for the combustion. The excess fuel is return to the fuel tank through the fuel return system provided. The fuel return should always be valve to the same tank from which the supply is drawn.

CAUTION!

Periodically inspect all connections for leakage and all tubes for damage. Replace as necessary. Clean the fuel filter frequently to ensure an adequate supply of clean fuel to the engine.

DANGER!

Do not drain fuel into the bilge. This could lead to fire, or explosion.

1.9 BILGE & DRAIN WATER SYSTEM

Make sure the Manual & DC bilge pump system is in good working order before you put out to the sea. Acquaint yourself with the way the bilge pump system of your boat works:

- Locate the manual bilge pump and the handle
- Locate the on switch of the electric bilge pump and get to know how the sea cocks work

Please see annex drawing for bilge capacity & system lay out

Bilge



The bilge compartment has one electric bilge pump of RULE1500 GPH and one manual bilge pump. All bilge pumps drain overboard through the common drains.

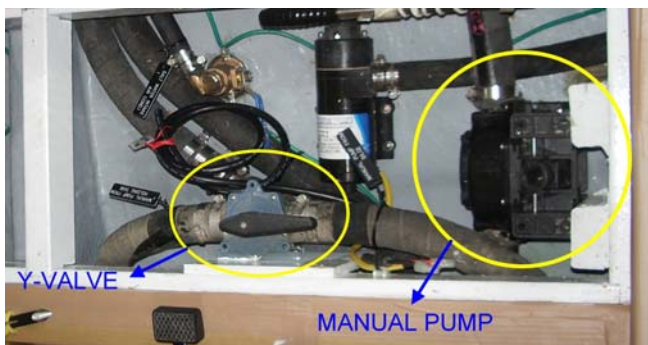



NOTE :

If any or all compartment contains an unusual amount of accumulated water, please check the operation of bilge pump by depressing the relevant switch and check the float switch as well. Clear accumulated water and rectify the fault immediately.

CAUTION!

Make sure that the bilge pump intake strainer is not blocked with dirt. Regularly clean the intake strainer on the sump and the filter of the system.

CAUTION!

Do not expect a manual bilge pump to save your boat if you have a problem. The bilge pump is not intended to enable flooding resulting from hull damage.

1.10 FRESH WATER SYSTEM

The fresh water system supplies the sink in the galley, the wash basin and shower in the head and the transom shower. This system is pressurized by an electric pump. There is a filter between the water tank and the pump. It is necessary to check and clean this filter regularly.

CAUTION!

Never run an electric pump when the tank is empty. It may burn out the pump.

To prevent any over pressure in the system during filling, never force the filling nozzle deep down the filter pipe and keep an eye on the vent hole(s) through which the excess water will be discharged

COLD WATER PIPE



HOT WATER PIPE

CAUTION!

When the system has not been used for a long period of time, the tank and pipe should be cleansed with an acetic acid solution (white vinegar). The water drains out from the sink and washes basins through their own through-hulls. Close them when the water system is not used.

WATER TANK

**WATER PRESSURE
PUMP**

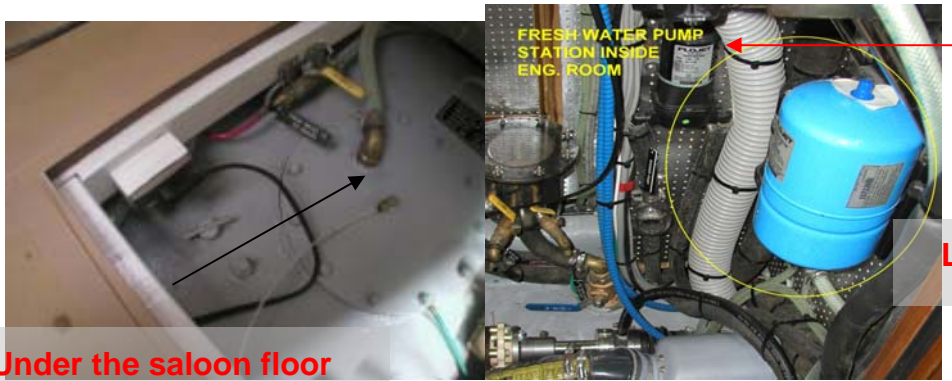

Under the saloon floor

Located in engine room

The fresh water system drawing is attached on appendices, and is serviced by two tanks with totally capacity of **964 liters (250 gallon)** . They located under the floor of main saloon. The tanks are constructed with Stainless Steel #304 and incorporate fore and after anti surge baffles to aid the vessel's stability.

The tanks are filled via decks filler located on deck port and starboard sides, The tank has a breather connected to a skin fitting in the vessel's top side. The breather should be checked and cleaned in accordance with the maintenance schedule, as any obstruction will impede the operation of the fresh water system.

The water tank gauge can verify the water level in the tank. This gauge is at navigation table

The fresh water pump is located in the engine compartment . Rust and dirt, taste and odor filters are fitted between tank and pump. lean or change the filters in accordance with maintenance schedule. The pump is activated automatically on demand by detecting the pressure drop caused by operation of a ta in the hot or cold water system.

The pump is powered through circuit breaker of DC, on nav. station DC control panel.

!

The pump should not be allowed to run dry, Switch off the FRESH WATER PUMP breaker switch on the DC control panel if the tank are empty or if any repairs or modification are being carried out to the fresh water plumbing system. If the system runs dry it will require you to shut off the circuit breaker, refill the tank and restart the system. To assist in reprimand the system open the main galley faucet to relieve the air from system. Reset circuit breaker after 20 seconds.

Cold Water System

Cold fresh water is distributed by pump to all the head's wash basins, showers, galley, transom shower, toilets,

The fillers are located both of the port side and starboard side.



The deck filler of water tank

CAUTION ! DO NOT LEAVE UNATTENDED ! CITY WATER PRESSURES CAN SINK YOUR YACHT IF A FITTING FAILS !

Hot Water System

The hot water system draws fresh water from the cold water System via a non-return valve to the water heaters located under the berth of main stateroom total capacity is 11 US gallons.

The water heaters operate on AC 220 immersion heaters powered by the generator or the shore power.

Hot water is distributed to the washbasins, showers, galley, transom shower.

If the vessel is to be laid up or left unattended in a cold climate, the entire fresh water system, including the pumps filters and water heaters should be drained to prevent Damage.

Please see annex drawing for fresh water system lay out

1.11 Toilet Shower/Sump/Common Drain System

This vessel is fitted with holding tank. Do not over fill the holding tank. Always discharge the swage when the holding tank is half filled.

– Consult the local authority for regulation of discharging swage. Environmental regulation may be difference in some waterways.

CAUTION!

Never run a macerator pump when the holding tank is empty. It may burn out the pump.

Toilet/Holding Tanks System

Manual toilet system is standard for your boat. All toilet waste is collected into FRP holding tank. The tank is located under nav. station floor, total capacity 22gallons (88 liters).

The macerator pump is installed near holding tank. Empty the tank is very simple.

1. Make sure to open the sea-cocks mentioned above, located under the seat cushion port side of salon. **DO NOT TURN PUMPS ON IF SEA-COCKS ARE CLOSED!**
2. Turn on the macerator pump breaker and monitor the level with inside holding tank. Do not let the pump run dry.

Dockside discharge is via cap fitting labeled “WASTE” on the starboard side.

WARNING !

MAKE SURE HOLDING TANK SEA COCKS ARE

CLOSED BEFORE USING A DOCKSIDE PUMPOUT.
FAILURE TO DO SO WILL DAMAGE THE PUMP

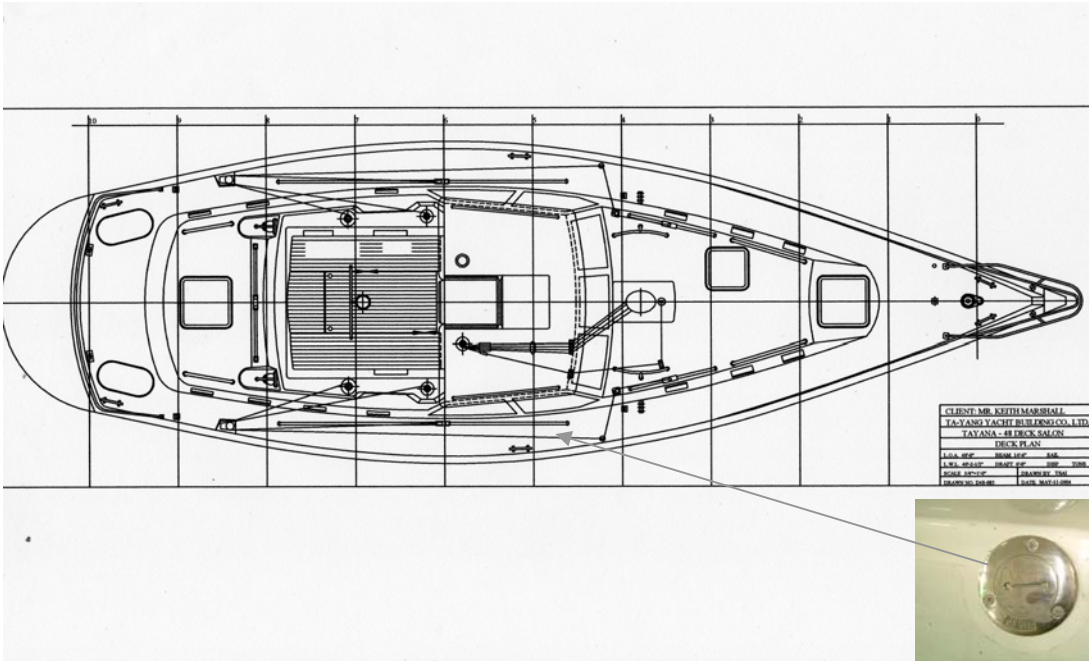

The location of deck pump out filler



HOLDING TANK

Shower/Sump/ Common drains System

The galley sink, and all shower wastes directly drain into the bilge water manifold which located in the stern cabin.

Danger !

Common drains must be cleaned once per year. Failure to maintain them can result in water restriction and water entry into yacht.

NOTE :

Common drains may be blocked by marine growth, such as zebra mussel or barnacles. If the drain is restricted the overflow of water will come out this relief vent and give you warning.



Please see annex drawing for waste water system lay out

1.12 Salt Water System / Seacock and Through-Hull

The salt water system is contained with:

- (1) Sea Water Pump
- (2) Sea Water Strainer
- (3) Check Valve
- (4) Sea-cock
- (5) Deck Side Discharger

Sea-cocks/Valves

Sea-cocks are fitted to all the water intakes below water line, i.e. engine sea water cooling, generator, sea water deck wash down, etc.

We recommend that all sea-cocks be left in the close position except when the system is in use. Sea-cocks should be returned to the off position after use and visually checked regularly for water tightness.

For toilets that is situated bellow the waterline, get into the habit of systematically closing the seacocks after each use.

CAUTION!

Close all the seacocks when you leave the boat. Make sure that all seacocks, which are not used, are closed before you put out to sea.

Opening and Closing of Seacocks



OPEN

CLOSE



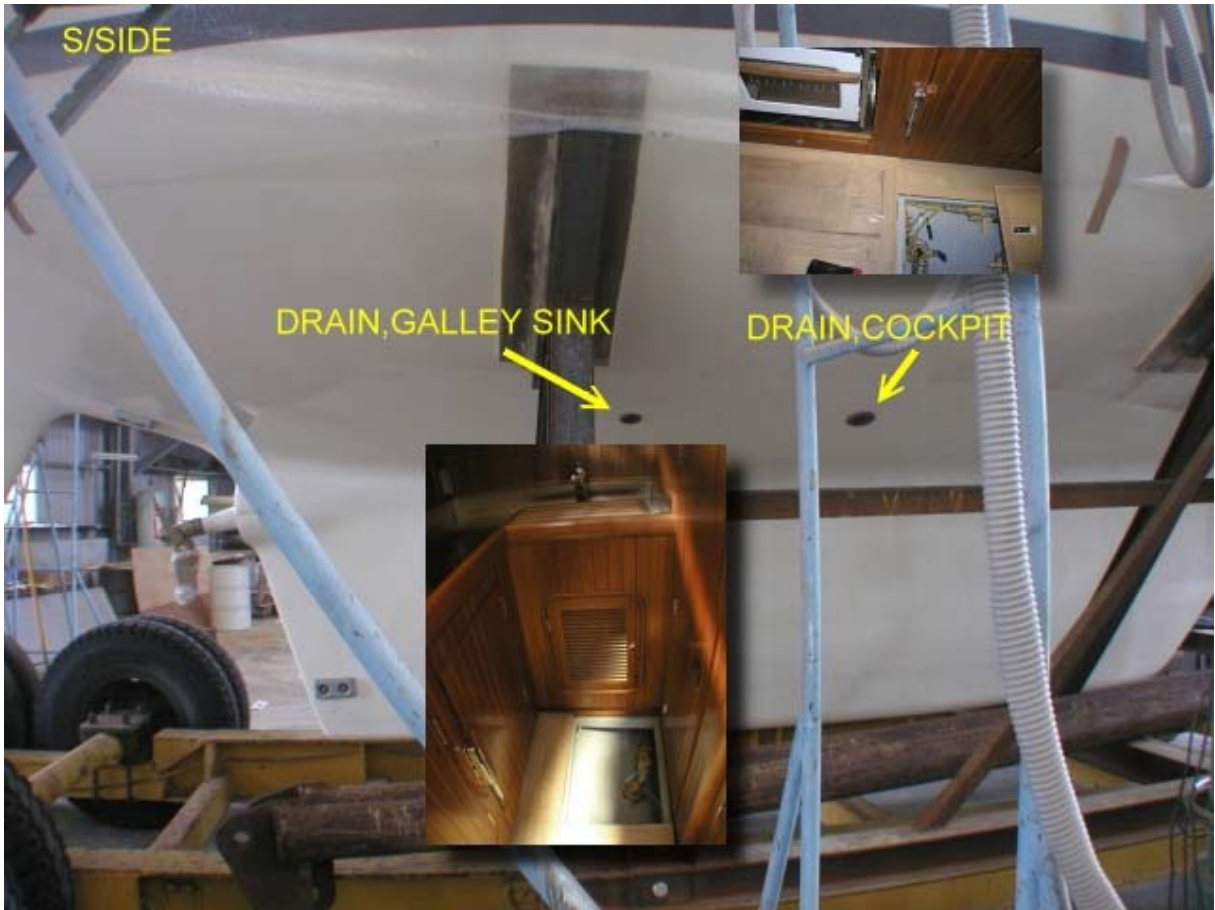



1.13 STEERING SYSTEM

Mechanical Steering System

This sailboat utilizes a mechanical steering system. Necessary information concerning the steering is in the “Mechanical Steering Owner’s Manual”. It is important that you read the manual carefully for maintenance and warranty.

One engine boat has one rudder. Rudder alignment is preset in the shipyard. Further alignment adjustments should not be necessary unless the rudder or steering system incurs damages. The steering system can be mechanizing without power.

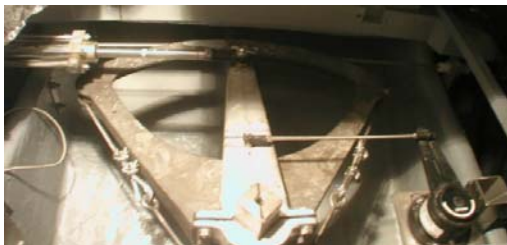

Emergency Steering System

The rudder post is provided with an emergency pin for use of there is a failure in the wheel steering system. Check at least once a year that the steering cables are properly tightened and lubricated.

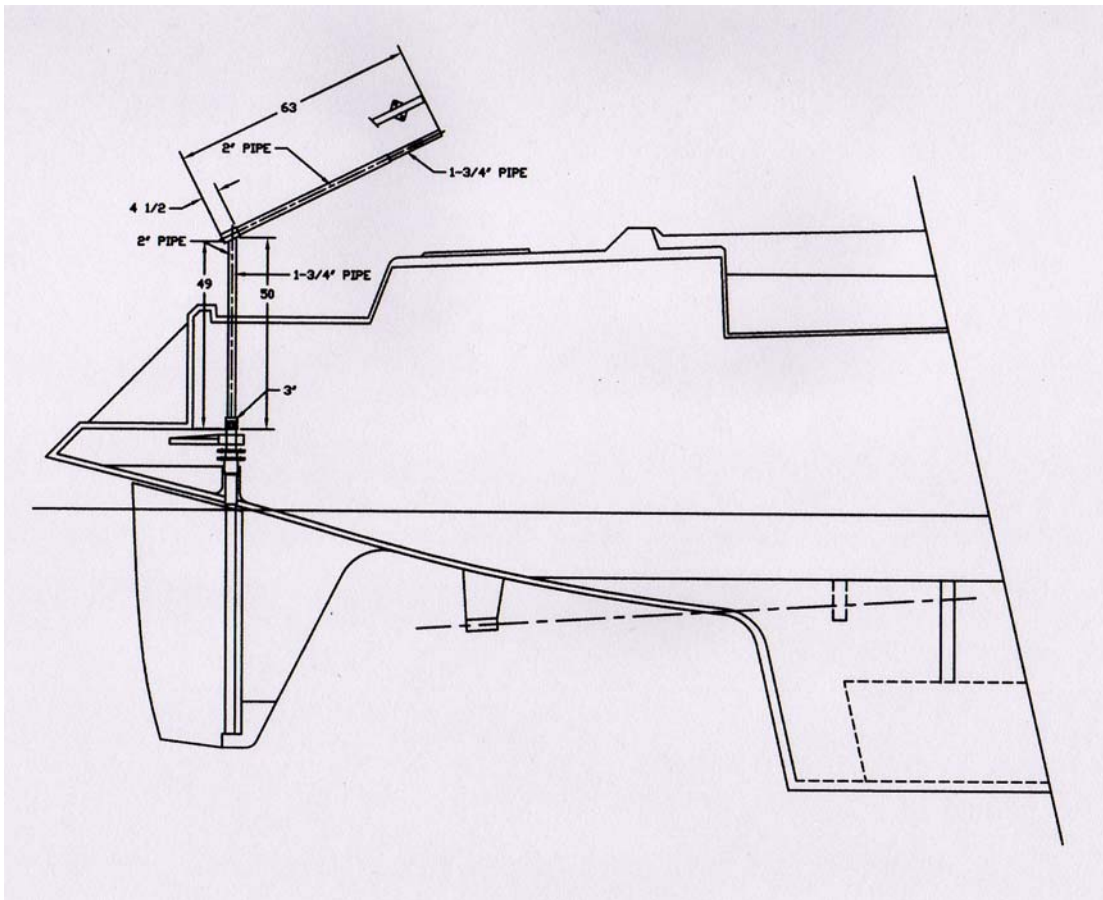

The deck plate of the emergency tiller is located at the after deck as the following photo which showed



The emergency tiller is placed inside the cabinet of the main cabin as the following photo showed.



1.14 SAILS AND RIGGING

Specifications of the Sails:

SAIL	AREA
	Optional Delivery Sails
Total	140.00 SQM
Mainsail	45.12 SQM
Staysail	21.00 SQM
Genoa 135%	73.88 SQM

I	62.00'	18.897M
J	18.75'	5.715M
P	55.50'	16.916M
E	17.50'	5.334M

NO	RIGGING	WIRE	PIN TO PIN LENGTH	PIN HOLD	QU.
#1	HEAD STAY	7/16"	65'-1/2"	3/4"	1
#2	FORSTAY	5/16"	47'-1-1/2"	5/8"	1
#3	UPPER SHROUD	1/2"	61'-4-1/4"	7/8"	2
#4	MIDSHROUD	3/8"	43'-6-3/8"	5/8"	2
#5	LOWER SHROUD	1/2"	24'-10-3/4"	7/8"	2
#6	RUNNING BACK STAY	5/16"	44'-0"	5/8"	2
#7	PERMANENT BACKSTAY	7/16"	40'-0"	3/6"	1
#8	BACKSTAY LEGS	3/8"	27'-9-1/4"	5/8"	2

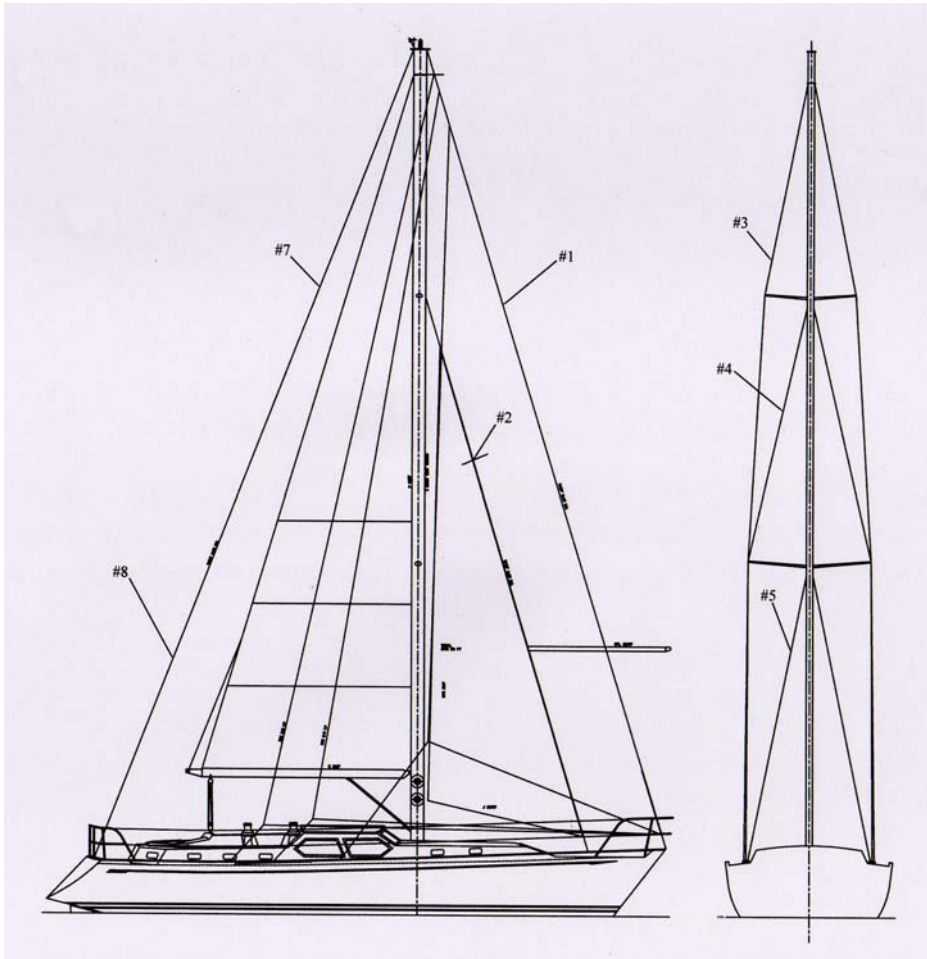

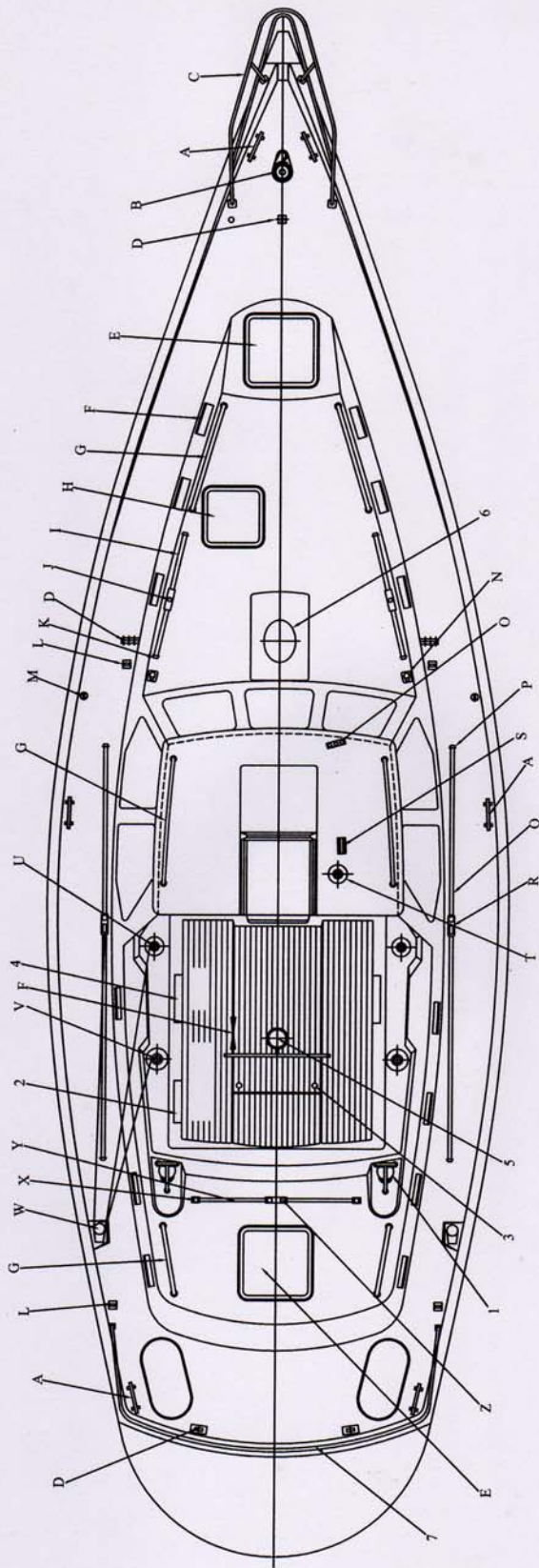

- ④ 12" 316 S.S. CLEAT
- ⑤ MAXWELL VWC 2200 WINDLASS
- ⑥ S.S. STEM PULPIT
- ⑦ S.S. CHAIN PLATE
- ⑧ LEWMAR OCEAN HATCH NO. 39670050
- ⑨ MANSHP S.S. 5"x12" PORT LIGHT
- ⑩ 304 S.S. HAND RAIL
- ⑪ LEWMAR OCEAN HATCH NO. 39650050
- ⑫ LEWMAR TRACK NO. 29162412
- ⑬ LEWMAR TRACKER CAR NO. 29042600
- ⑭ LEWMAR TRACK END NO. 29172040
- ⑮ S.S. PAD-EYE
- ⑯ BLOCK LEWMAR NO. 9317-8310
- ⑰ BLOCK LEWMAR NO. 8314
- ⑱ BLOCK LEWMAR NO. 29139103
- ⑲ LEWMAR TRACK END NO. 29173040
- ⑳ LEWMAR TRACK NO. 29163440
- ㉑ LEWMAR TRAVELER CAR NO. 29043600
- ㉒ LEWMAR D2 ROPE CLUTCH
- ㉓ LEWMAR 44 CEST ELEC. WINCH
- ① ① LEWMAR 44 CST WINCH (P&S)
- ② LEWMAR 34 CST WINCH (P&S)
- ③ LEWMAR SZ-4 NO. 8435 FOOT BLOCK (P&S)
- ④ LEWMAR TRACK END NO. 29173030-29173011 (P&S)
- ⑤ LEWMAR TRACK NO. 29163118
- ⑥ LEWMAR TRAVELER CAR NO. 29033400-29173014
- ⑦ MANSHP 304 S.S. DORADE VENT & 304 S.S. GUARD (P & S)
- ⑧ YANMAR NEW C PANEL
- ⑨ S.S. COCKPIT DRAIN (P & S)
- ⑩ FRP TOOL BOX (P & S)
- ⑪ LEWMAR STEERING
- ⑫ SELDEN MAST 274/185
- ⑬ S.S. STERN PULPIT

1.15 SAFETY EQUIPMENT

Life Vests

Keep a proper amount of approved life vest on board for each crew.

Flares

Your yacht to be equipped with a minimum of three day/night flares.

Medical Kit

A basic medical kit is a wise investment for any boat owner. Suggested items includes: motion sickness pills, aspirin, bandages, etc. We recommend that you personalize your medical supplies for yourself and your crew specific needs. First aid kits are available at most marine stores. Consult your physician for his recommendations, if you are planning a voyage away from medical facilities. A first aid procedure book is a necessity.

Other Tooling

A varied arrangement of tools is, again, a wise investment to have on your boat. Tailor your toolbox for the conditions that you cruise. For local cruising, with professional help just a call away, you only need a small array of tools. However, for long range cruising, a more extensive supply of tools will be needed. Your mechanic may be helpful in suggesting tools required tools required for your particular engine installation.

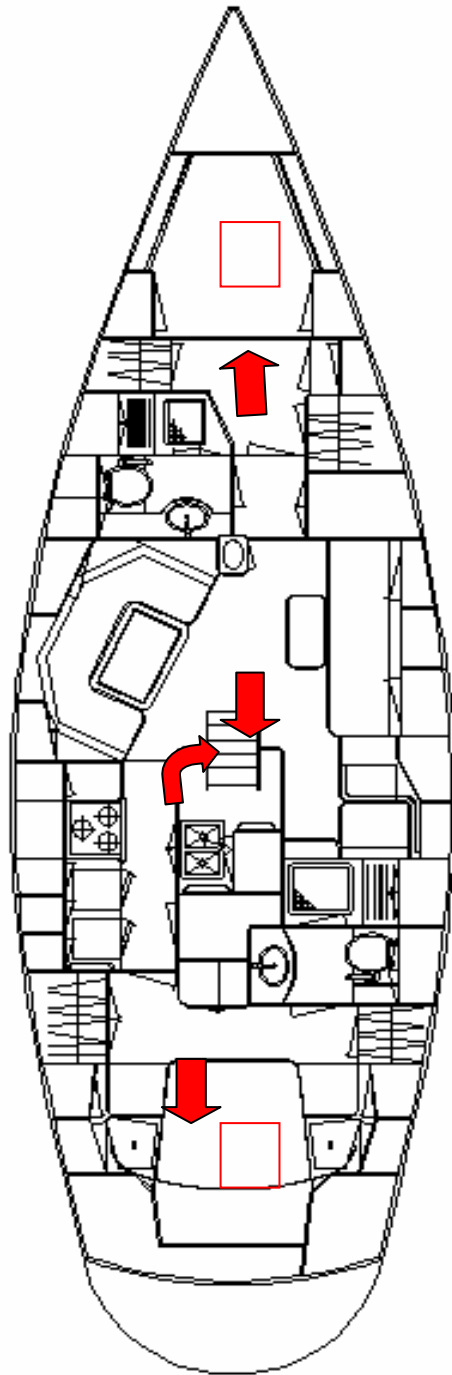

EXIT IN CASE OF FIRE

Man-overboard prevention and recovery :

1. Clause 4.1 working deck area.
2. Clause 16 Description of the means of reboarding.

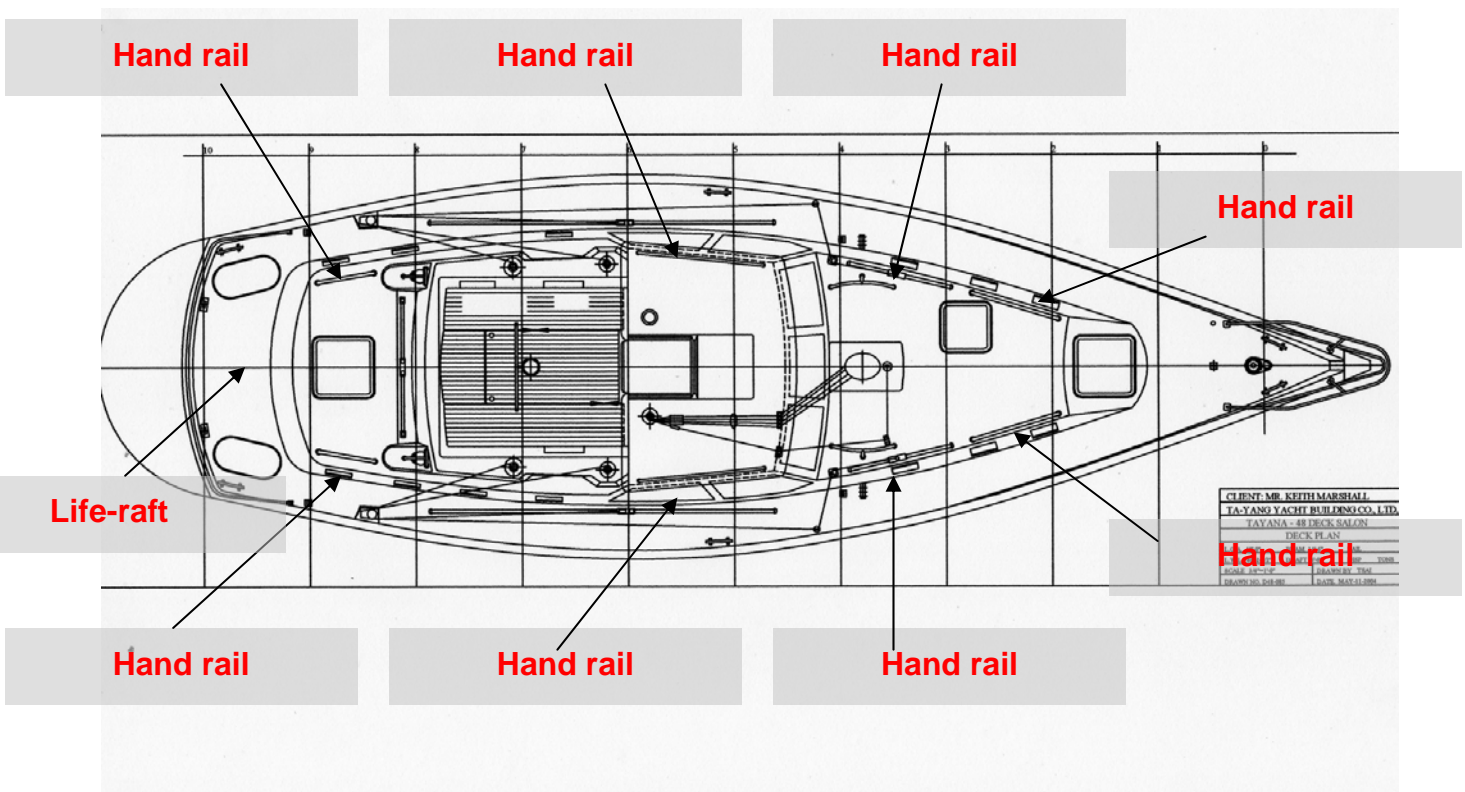

Please see annex drawing (deck plan) for the details of deck

ISO 15085 : 2003

Clause 16 Description of the means of reboarding

The boat has a ladder on transom area for people reboarding and the top surface of the lowest step of the reboarding is 600mm below waterline. (the boat being in minimum sailing condition)



MAINTENANCE

Your boat needs special and regular care safeguarding your investment and looking after your own safety should persuade you of the importance of careful and regular upkeep of your boat. The maintenance suggestions in the following sections will help you with the basics. Always refer to the original manufacturer's manual for specific guideline on individual components.

It is important to clean the bottom of your boat at least two or three times a year.

2.1 General Hull Maintenance

CAUTION!

- Do not sand the hull with coarse sandpaper.
- Do not use solvents clean hull
- Do not wash with pressure machine using water warmer than 21 degree C (70 degree F)
- Do not use pressure exceed of 150 bar when using a high pressure spray wash.
- Do not hold nozzle closer than 10 cm (4 inches) to the surface hull
- Do not machine sand

We believe the above points to be pertinent to all FRP boats.

2.2 Gel Coat

The gel coat is vulnerable to any dents and scratches it may get during maneuvering in harbor and on a mooring. The best way to avoid them is to undertake maneuvering calmly, after thinking out all the relevant factors (such as speed, current, wind, and the layout of harbor). Always have one of the crew

ready to put out a fender at the right place. When bringing in the anchor chain, back off or swing the boat round so as not to rub the chain against the hull. Hold the anchor well clear as you bring it aboard so that it does not scrape the stem: lay it on deck and lash it down at once, if only temporarily. Never use dirty fenders.

2.3 Fiberglass/Gel Coat Stains & Scratches

Gel coat and painted surface are very resistance to deep stains. Common surface stains can be removed with diluted household detergents, providing these detergents do not contain ammonia or chlorine. Porcelain-cleaning powders are too abrasive and often contain chlorine and ammonia, either of which would permanently discolor the Gel Coat and paint. Alcohol or kerosene can be used for difficult stains but should be washed away promptly with a mild detergent and water. Never use acetone or ketone solvents.

Minor scratches and deeper stains without penetrating the Gel Coat may be removed by light sanding and buffing.

2.4 Fiberglass/Gel Coat Special Care For Boats That Are Moored

If permanently moored in salt water or fresh water, your boat will collect marine growth on its bottom. This will detract from the boat's beauty and greatly affect its performance. There are two methods of preventing this:

1. Periodically haul the boat out of the water and scrub the bottom with a bristle brush and a solution of soap and water.
2. Paint the hull below the waterline with a good grade of antifouling paint. DO NOT paint the engine drive surface.

NOTE: There are EPA regulations regarding bottom paint application. Consult your dealer for proper application methods.

2.5 Bottom Paint Care

From time to time, a slight algae or slime formed on all vessels. The bottom painted portion of the hull can be wiped off with a coarse Turkish towel or piece of old rug while the boat is in the water. Do not use a stiff or abrasive material to clean the bottom paint.

The bottom paint should be inspected annually. If it needs repainting, flush the old paint and wash with hot water and laundry detergent. Rinse well and let surface dry completely. Feather any deep scratches with sandpaper and repaint, following the directions on the bottom paint label.

CAUTION!

Fiberglass hulls should never be hauled, painted and re-launched the same day, since this does not allow sufficient time for the moisture, which has been absorbed into the old paint film to completely dry out. Generally, 24 to 36 hours of drying time is required.

2.6 Plexiglas

To clean Plexiglas, first flood it with water to wash off as much dirt as possible. Next, use your bare hand, with plenty of water, to feel and dislodge and caked dirt and mud. A soft, grit-free cloth may then be used with a nonabrasive soap or detergent. A soft sponge, kept clean for this purpose, is excellent. Blot with a clean, dampened chamois.

Grease and oil may be removed from Plexiglas with kerosene, hexane, white (not aviation or ethyl) gasoline or aliphatic naphtha (no aromatic content).

Remove fine scratches with fine automotive acrylic

rubbing and polishing compounds.

CAUTION!

Never use a dry cloth or duster, or glass cleaning solutions, on Plexiglas.

CAUTION!

Do not use solvent such as acetone, silicone spray, benzene, carbon tetrachloride, fire extinguisher fluid, dry cleaning fluid or lacquer thinner on Plexiglas, since they attack the surface.

2.7 The Deck and Deck Fittings

Using a gentle liquid detergent, scrub all nonskid areas to keep them free of dirt. Light-alloy sections can be cleaned in the same manner.

The tiny spots of oxidation pitting that may appear on stainless steel parts are nothing to worry about. Polishing will remove them.

Follow the manufacturer's instruction carefully. When dismantling deck fittings, have a bowl close at hand for putting the parts in, and circle the area with a rolled dishcloth, or the like, so that any screws or springs you drop do not roll overboard. Use the lubricant recommended by the manufacturer before reassembling.

WARNING!

Incorrect reassembly can cause accidents. Note the order in which parts are dismantled, which will make it easier to put them together again later.

Acrylic plastic hatch covers and portholes should be rinsed off with fresh water and rubbed over with a soft cloth soaked in

liquid paraffin.

2.8 Interior Wood

The internal woodwork used in most of our boats is varnished. This should be regularly rinsed off with fresh water and a little liquid detergent, and polished with chamois leather.



Should the woodwork become damaged, gently rub it down with very fine sandpaper and touch it with several coats of the varnish. When this is dry, rub it down with very fine wet-and-dry sandpaper (grade 800 or 1000) and finish off with polish (or a silicone spray) or wax.

2.9 Exterior Vinyl Care

Exterior vinyl requires periodic cleaning to maintain its neat appearance and to prevent the buildup of dirt and contaminants that may permanently stain and reduce the life of the vinyl if they are not removed. The frequency of cleaning depends on the amount of use and environmental conditions to which the vinyl is subjected.

The procedures used for cleaning are dependent upon the end use circumstances.

CAUTION!

Powdered abrasives, cleaners containing abrasives, steel

wool and industrial strength cleaners are not recommended for vinyl.

CAUTION!

Any lacquer solvent will cause immediate, irreparable damage to the vinyl. (Solvents will remove the topcoat on the vinyl, allowing the plasticizers to migrate, causing first a tacky surface and next the surface will become hard and crack with irreparable damage.)

Wax or protectors should never be used on any vinyl upholstery, as it will cause premature embitterment and cracking.

Dilute chlorine bleach before using. Never use at full strength.

If flammable solvents such as alcohol, turpentine or varsol are used for cleaning, only small quantities should be employed in a well-ventilated area. Exercise proper care by advising any personnel in the area and keep away from any ignition source. Always wear protective gloves.

In general, most common stains can be cleaned using warm, soapy water and clear water rinses. Moderate scrubbing with a medium bristle brush will help to loose soiling material from the depressions of embossed surfaces.

CAUTION!

Detergents should never be used on a regular or repeated basis for normal cleaning.

Full strength rubbing alcohol or mineral spirits may be tried cautiously as a last resort on very stubborn stains, if the above suggestions do not work. Indiscriminate use of any solvent or solvent-containing cleaner can severely damage or discolor the vinyl.



2.10 Daily Checks

- (1) Check **engine oil level** (Refer to engine handbook), and make sure that oil level is within the marked limits on the dipstick
- (2) Check the **engine coolant level** is filled to maximum (Refer to engine handbook).
- (3) Operate the engine room **exhaust fans** for few minutes before starting the engines
- (4) Make **a visual check** of the engine room that bilge is dry and everything looks in order. Also check there to be sure there are no fuel fumes present

IT IS ESSENTIAL THESE CHECK ARE CARRIED OUT DAILY BEFORE THE BOAT IS STARTED

Periodic Maintenance

PERIODIC is a term to indicate a time scale based on the actual usage of the boat. For a boat used for only a few weekends during the summer, PERIODIC could mean “ANNUAL” whereas, if the boat is used continually on a daily basis it could mean “WEEKLY”.

2.11 Battery Electrolyte

All batteries installed to TAYANA48DS need to check water level at certain of time.

2.12 Corrosion Protection

(Sacrificial Anodes)

Sacrificial anodes are fitted to the boat to protect this under water metallic parts i.e. propellers, shaft, skin fittings, etc, from corrosion. The main anodes are fitted at transom. The shaft, rudder have anodes fitted as well.

These should be replaced when about half of the anode has been consumed. It can depend very much on the environment in which the boat is moored as to the length of time the anodes will last. It can range from 4 months to 12 months. We recommended that they be inspected every 3 months.

!

IN ANODES ARE ALLOWED TO CORRODE AWAY TOTALLY, THIS COULD RESULT IN SERIOUS PARTS WITH THE POSSIBILITY OF THE BOAT SINKING

Crevice Corrosion

When your vessel is in wet storage, rotate both propeller shafts about once a week to prevent crevice corrosion, which may occur in the area of struts and shaft logs if the shafts stay in the water in the same position over a long period

Electrolysis

If your vessel is idle for extended periods, we recommend that a "Zinc fish" be hung over the side in the water on a heavy wire with a clip at the other end of this wire attached to your vessel's electrical bonding system

The use of “zinc fish” will help control the electrolytic action affecting the components mounted through the hull. When a zinc has greatly distinguished, it should be replaced as it will no longer be effective. “Zinc fish” can be purchased from a marine supply store.

CAUTION!

Remove the zinc from the water before any attempt is made to move the boat under power. Replace the standard transom zincs as required.

Check the engines and generators zinc anodes. Please refer to engine and generator’s Operation Manual.

2.13 Mechanical

Periodically check the control mechanism for looseness and signs of water on moving parts, particularly the cable terminals. Lubricate all moving parts with good quality marine grease. Spraying the engine and mechanical parts with a good quality damp proof lubrication spray such as W.D. 40 will keep the engine free from corrosion.

2.14 Propeller Shaft

- (1) If your boat is idle for extended periods, it should have the shafts rotated about once a week to avoid crevice corrosion. Schedule depends on water condition and temperature. Higher salt content, warmer temperature and water pollution will require more frequent shaft rotation.

- (2) Avoid contact with floating objects and running aground since excessive stress may bend, fracture or initiate a crack, which will ultimately result in a failure when least expected
- (3) Common sense usage of the throttle will help to prevent undue stress on shafts and avoid premature failure
- (4) Zinc anodes generally require replacement about once a year. The need to replace anodes more frequently may indicate a stray current problem within the boat or at the slip or mooring. If zincs do not need replacing after one year, they may not be providing protection or low grade zinc may be the problem

2.15 Propeller

Propeller Installation

Propeller installation completes your vessel's propulsion system. With the engine output converted to vessel movement, mating the shaft to the propeller must be done properly to provide maximum shaft and propeller life. If you must replace either the propeller or the shaft, following these guidelines :

- (1) Each propeller is keyed to shaft with a locating pin extending from the key. Check that the key fits snugly in its slot with the pin in its matching hole in the shaft key way.
- (2) Check the fit of the propeller on the shaft with the key
- (3) If the key does not fit, carefully file the propeller key way using gentle and even file strokes along the hole key way
- (4) Place the propeller on the shaft without the key and seat the propeller on the shaft taper. The fit should be tight with no wobble and no space between the shaft and forward and after ends of the propeller hub

- (5) Mark the location of the propeller on the shaft at forward end of hub with a sharp pencil
- (6) Remove the propeller
- (7) Insert the key into shaft key way and ensuring that the location pin is in its hole in the propeller shaft key way
- (8) Reinstall the propeller
- (9) Ensure that the propeller is fully seated with the forward end of the hub touching the pencil line you made in step 5
- (10) Use a feeler gauge to check for 0.006 and 0.010 inch clearance between the top of the key and the bottom of the key way in the propeller hub
- (11) Remove the propeller
- (12) Coat the bore with any non-graphite waterproof grease
- (13) Reinstall the propeller
- (14) Install the nut
- (15) Torque the nut with a wrench to seat the propeller
- (16) Look both nuts together and install a cotter pin and bend the Legs.

Propeller Maintenance

Inspect the propeller blades, and check the hub for cracks. If there is a significant amount of metal eroded or clipped from propeller, please check the propeller balancing. Making sure all the blades are in the same plane, not bent and in balance.

NOTE :

Apply marine grade grease between shaft and propeller hub when propeller is installed.

2.16 Fresh Water Pump Strainers

Fresh water pumps strainers are located inside eng. room. These should be cleaned periodically, depending on how clean the available fresh water is.

2.17 Shower Drain Sump

This should be cleaned about twice a year. Sump tanks are located underneath master stateroom forward. Lift up the hatches under the bed and washbasin on port side, you will see the plastic covers.

To clean, first remove the plastic cover. Remove any build up of hair around the base of the sump and clean out any dirt from the sump. Run the shower to check that the pump and float switch are operating correctly.

2.18 Boat Exterior

The boat is constructed from fiberglass, or also known as fiber reinforced plastic-FRP. Maintenance consists essentially of keeping the finish in like new condition. A fiberglass boat does not need painting to protect it from deterioration. Paint is applied to above water structures for cosmetic reasons only if preferred. The only recommendation for the exterior is to add anti fouling paint to protect the fiberglass bottom from barnacles and other marine growth

The low maintenance characteristic of fiberglass boats eliminates many time-consuming seasonal maintenance jobs,

reducing the frequency of others and bringing about a change in materials and techniques.

The one-piece construction eliminates seams and the working of the hull with all the attendant maintenance problems. Barring accident, well-built fiberglass hulls stay solid, safe and leak free for many years.

The key to the appearance of a fiberglass boat is the surface finish, which is called gel coat. It is the gel coat that takes all the weathering, dirt, and minor spaces.

2.19 Cleaning of the Fiberglass

Depending on water conditions and use, the boat can pick up a film of dirt. To keep fiberglass looking fresh and clean, wax and buff the surface at least once a year and wash regularly. It is essential that salt deposits are washed off with fresh water before leaving the boat.

For washing, a solution of warm water and mild detergent should be used, followed by thorough hosing with fresh water.

A seasonal buffing and waxing of the gel coat surface helps to prevent soiling and preserve gloss and color. In most cases an ordinary fine grade auto polish or combined polish/cleaner will serve this purpose. However, if the finished has faded or exhibits a chalky film, a fine grade auto -rubbing compound should relieve the condition. Whether a power buffer is used or the polishing is done by hand, it is undesirable to use more than a lightly abrasive and edges, not to cut through the gel coat.

We recommend dark colored hulls be waxed twice per year to maintain their luster. Any high quality wax may be applied after buffing. Generally speaking, treat the finish of the yacht in the same way as the finish of a car keeping in mind that the yacht endures much more harsh conditions, often without shelter.

Color Fading

Some pigments fade somewhat in time, especially when exposed to intense sunlight and salt.

Surface Crazing

The hairline crazing that appears after a time on the surface finish, requires only cosmetic treatment. This crazing goes no deeper than the gel coat. Should this occur or if the surface is scratched in use, this can be simply rectified by someone who is experienced at gel coat repairs.

2.20 Teak Decks

Teak requires very little maintenance. It is possible to leave teak to weather. Cleaning the teak deck at cockpit is basically wearing them away either by abrasion like sanding or by acid or both. To enhance the life of your teak decking and deck seams, please do the following:

- (1) Keep your deck clean but do not over do it.
- (2) Use plenty of fresh water during all stages of cleaning.
- (3) Follow cleaner manufacturer's instruction carefully.
- (4) Use flat scrubbing pads, they will not dig into the grain and wear it evenly.
- (5) Do not use harsh acid based chemical cleaner.
- (6) Do not use stiff brittle brushes on teak deck. They will dig into wood's grain, especially when wet.

!

DO NOT USE DECK CLEANER THAT CONTAIN OXALIC AND PHOSPHORIC ACID. SOAP SOLUTION SHOULD BE USED FOR TEAK DECK CLEANING ONLY. TO ENHANCE THE LIFE OF DECK SEAMS,

DO NOT APPLY STRONG DETERGENT.

2.21 Anti-Fouling & Marine growth

We recommend the bottom of the hull painted with a good quality anti fouling paint to prevent marine growth and barnacles as this will affect the speed of your vessel. Anti fouling paint should be applied per manufacturer's instructions. Before repainting your vessel's bottom, you should check to be sure the brand and type of paint you have chosen are fully compatible with the type presently on the vessel.

NOTE :

- (1) Avoid heavy sanding of the hull bottom**
- (2) Do not paint on zinc. Use only manufacturer's recommended paint on the depth sounder transducer.**
- (3) Some type of anti fouling paints are not compatible unless a primer is used first**

Before Applying Anti-Fouling Paint

When the boat is hauled for painting, it is normally annual Maintenance. Please refer to maintenance schedule and check all the items are necessary. For underwater objects, the following should be inspected :

- (1) Cutlass bearing of rudder and shaft
- (2) Sea cocks
- (3) Propeller and propeller key on each shaft for tightness and

condition. And check the lock nuts and pins.

- (4) Check the condition of all underwater fittings

2.22 Care & Clean of Acrylic Parts

Acrylics are soft and their surface can be scratched easily by improperly cleaning. The scrubbing tools for FRP surface should never be used to clean these parts.

When installing or reinstalling acrylic parts that are fastened with screws, do not use a power screwdriver to run the screws all the way down. Make the last few turns by hand to avoid over tightening and stress cracking the part.

To Clean Acrylic

- (1) Use a mild soap and plenty of warm water with a soft, all cotton cloth and apply only light pressure
- (2) Rinse with clear water and dry by blotting with a damp cloth
- (3) Kerosene may be used to remove some grease or paint

!

WHEN CLEANING ACRYLIC PARTS, DO NOT USE SOLVENT SUCH AS LACQUER THINNER, ACETONE AND DO NOT USE ABRASIVE CLEANERS.

USE MILD DETERGENT WITH WARM WATER AND PURE NATURAL COTTON CLOTH.

TO REMOVE FINE SCRATCHES YOU MAY USE MEGUIARS MIRROR GLAZE #17 BRAND OF POLISHING COMPOUND.

AVOID HIGH TEMPERATURE WHEN POLISHING

ACRYLIC PARTS.

2.23 Upholstery Etc

Cockpit Upholstery

Never store these cushions wet, even through the foam used is closed cell foam. When cleaning, do not hose down the upholstery but wipe down with a damp cloth. Any surface water should also be removed from the seat with a damp cloth.

To Clean Vinyl

A soft cloth and warm soapy water should be used to clean the surface of material. Mild liquid soap or soap flakes are recommended and residual soap should be removed with cold water. The surface should then be dried with a clean soft cloth.

Cabin Upholstery

The cushions in the vessel are made of foam and some of the covers can be zipped off for cleaning

Ultra Leather and Ultra Suede

The interior of boats may be covered with these materials, such as sofa, ceiling, etc. The attractive appearance and soft touch are long lasting and easy to maintain. Any dirt spot should be treated immediately in the following way. Wipe stain from the border of spot to the center to prevent the stain from spreading outward. Use the type of cleaning agent recommended in the list below according to the type of stain. Gently remove any free matter with spoon or table knife and immediately pat the stain with a clean white cloth. When using a solvent do not pour it directly, but sprinkle it on a clean cloth. After applying spot

remover wipe it away with a dry clean cloth. Brush against the nap. Allow the material to dry, do not sit on wet fabric. When dry, remove any residue with vacuum cleaner.

RECOMMENDED CLEANING AGENTS

Type of stain	Cleaning Agent & Action
Liqueur/spirit	Shampoo. Then pat with denatured alcohol
Beer	Pat with a 3% solution of denatured alcohol and warm water max.50C (122F)
Coffee	Shampoo. If necessary pat with 10% solution denatured alcohol or ammonia
Chocolate/sweets	Pat with warm water (max 122F).
Colors	Oil paint, pat with ethyl alcohol and shampoo. Water color, pat with cold water. Spot can be removed if cleaned immediately. If left too long cleaning may be difficult
Cosmetics	Use ethyl alcohol and shampoo
Fruit	Pat with warm water max. 122F and shampoo.
Chewing gum	Pat with acetone
Ink	Remove as much as possible with blotting paper and pat

with a solution of 30% denatured alcohol and 70% water. Then shampoo. Lemon juice also can give good results

Jam	Pat with warm water
Fruit juice	If necessary use ethyl alcohol
Ballpoint pen	Use denatured alcohol
Wine/Soft drinks	Use water and vinegar 50% and shampoo
Fat/Oil	Pat with denatured alcohol and shampoo

2.24 Light Fittings

For taking care of light fittings, you should follow these rules.

- (1) Keep salt water away
- (2) Wash lamps at intervals, using a soft cloth and fresh water. Polish very lightly with soft cloth to avoid scratching the lacquer
- (3) Never use thinner. Thinner may remove the lacquer away.
- (4) Do not polish lacquer with common polishes or abrasives.

To keep your beautiful light fittings for years, you should follow the lamp manufacturer's instruction as follows:

- (1) Treat each lamp with liquid wax once or twice a season. Following the wax makers' instruction. Do not use any wax with abrasive or silicone based.
- (2) Avoid sea spray to brass fittings.

- (3) If the fittings contact with seawater, wipe it and clean immediately and apply wax to protect the surface
- (4) Clean and apply wax on the fittings surface during off season.

2.25 Metal Fittings

Chrome Fittings

Maintenance of chrome fittings is largely the same as Aluminum; normal maintenance involves only occasional washing with household cleaner and periodic waxing. However, you can achieve a really good result by using specialized chrome cleaning such as autosol followed by wax polish.

Stainless Steel Fittings

Stainless steel is not totally as the name describes. For if it is not cleaned regularly, you will find an accumulation of surface staining caused by several difference factors. A good quality chrome cleaner will remove any staining also regularly wash over a solution of mild detergent and warm water will keep it looking in good condition.

As time passes surface impurities caused during manufacture will be removed and staining will decrease.

2.26 Cold Water Precautions

!

FAILURE TO DRAIN ALL THE FRESH WATER CAN

RESULT IN SEVERE AND EXPENSIVE FROST DAMAGE

If you stored your vessel in winter season, please check the following:

- (1) The engine have been prepared for the winter
- (2) The antifreezer has been added to the engine and generator's fresh water cooling system or else drained
- (3) Ensure that the following have been thoroughly drained :
 - (a) The domestic fresh water system, pumps, hot water tanks, sump tanks and pipes.
 - (b) The toilet system, including the pipes and holding tank

2.27 Appendices

- (1) Maintenance Schedule
- (2) Propeller Manufacturer's Certificate
- (3) Vessel profile and related dimension
- (4) Conversion Table
- (5) Safe operation instruction

OPERATING INSTRUCTION

A new boat owner, who lacks operating experience should be accompanied by an experienced operator until he becomes familiar with the control. After learning the fundamental rules of maneuvering, practice will perfect these fundamentals and make him adept in handling the boat.

3.1 Useful Hints Before each Journey

- (1) Check weather to determine if conditions are safe and suitable.
- (2) Check that all safety equipments are located on board and are located where you can get it in a hurry and that the safety equipments are in good conditions.
- (3) Conduct a radio check to make sure the radio is working.
- (4) Check that all navigation lights are in operation
- (5) Include somebody in the group who is able to operate the boat in case something happens to you
- (6) Store and secure all loose gear before you get underway
- (7) Proceed to do the starting checks for engines
- (8) Check the bilge and operation of each bilge pump installed

When embarking on a trip of some length, tell friends or relatives the planned route and expected time of arrival.

3.2 Pre-start Checks

Before starting the engines make sure that you inspect the engine room:

- (1) There is no **fuel leakage**

- (2) There is no **water leakage** from the engine or hull
- (3) There is no **oil leakage**
- (4) There is no **smell of Lp, gas or diesel** in the deep cavities of the boat or elsewhere
- (5) The **oil level** is correct. Please refer to engine handbook.
- (6) Check **cooling water** level in the expansion tanks for the correct amount of fresh water
- (7) There is enough Fuel on board for the planned voyage

!

Ventilate the boat and run the engine room fans before start the engines.

Instruct all passengers and crew on board the working of the boat and where to find the life jackets and the fire extinguisher etc. Also tell them everything else you think necessary from the point of view of safety.

Should something unexpected happen during the voyage, very often it is too late to tell those on board how the safety equipment works.

3.3 Starting the Engine

- (1) Check sea-cocks are open.
- (2) Switch on the main battery switches.
- (3) Turn on the fuel taps.
- (4) Start the engine room fans and allow it to run for a few minutes before starting the engines.
- (5) Make sure there is no obstacle near the propellers. Make sure gears are in neutral position.
- (6) Turn the key switch on and start the engine. Release the switch when the engine has started.

To obtain good operation economy the engine should not be run at maximum speed for long periods. See engine manual for correct maximum speed.

Note that the reduced speed for long cruising is 300-400 rpm less than the normal maximum speed.

Check that the engine temperature is normal within 30-70°C (86-158°F) and the instrument for charging and oil pressure show normal values. If abnormal values are shown the engine must be stopped immediately and investigate it.

If when starting, the engine will only turn over slowly and will not start, operate the battery cross system located in engine room and keep it engaged while starting engine. This links the main battery banks together.

Check the instruments ! Expensive repair bills and unnecessary trouble can be avoided if the instruments are checked frequently, especially when first starting the engine. By keeping a careful watch it is possible to detect a malfunction before any serious damage occurs.

DANGER!

Always start engines with shaft control level in neutral.

Some electronic controls allow starting in gear.

!

Failure to release ignition key after engine starts may damage the starter motor and drive.

Do not operate the starter continuously for more than 30 seconds. Allow starter to cool down at least 2 minutes between starting attempts.

3.4 Cold Starting

In cold weather additional steps may have to be taken. These vary according to the engine maker and model. For details please refer to engine manufacturer's manual.

3.5 After the Engine Have Started

- (1) Allow engines to warm up. Check water temperature gauges to be sure water temperature remains within specified range. If temperature gauge reads abnormally high, STOP ENGINE IMMEDIATELY and determine the problems.
- (2) Check the engine exhaust outlets to make sure water is flowing.
- (3) Check around the boat, to be sure there of no obstructions and it is safe to get underway.
- (4) Check the engine room to ensure there are no oil, fuel or water leakage and all equipment is secured properly.

3.6 Running In

A new engine has to be run in with special care during the first period of operation. Do not run the engine under full load during this period. Oil consumption can be expected to be higher than normal during the running-in period and so it is necessary to check the engine oil level at frequent intervals. Please refer to engine handbook.

3.7 Maximum engine speed

Refer to the engine handbook for exact detail for particular engine fitted.

NOTE :

If the boat has been in the water for some time the

speed and the maximum engine speed can drop as result of weed growth on the hull.

Please refer to Maintenance of “antifouling ”.

3.8 Casting Off

The experienced sailor will check that all equipment is stowed well and safety. In bad weather the side doors and portholes have to be closed. Keep the boat hook and warps within easy reach.

Once the engines are running smoothly, release the mooring lines fore and after, taking care not to let the lines become entangled in the propeller.

Go slowly out of harbor. Once free of the quay and of other boats, pull the fenders aboard and stow them in a place where they are easily accessible.

3.9 Docking

Nowadays it is often necessary to squeeze the boat into a comparatively narrow docking space.

Have the fenders in place along both sides of boat, have the boat hook and mooring lines at hand.

When mooring, handle the boat with extreme caution. Ideally at idle speed, because the momentum of a heavy boat moving can be difficult to stop if the boat is moving quickly.

As described your best maneuverability is provided by using a combination of your gearshifts, steering and thrusters.

To turn within a narrow space, utilize the bow and stern thrusters. It will make it easier to move toward starboard side. However, this operation requires some practice.

3.10 Shutting Down

Before stopping the engine it should be allowed to idle for a minute or two with the control level in neutral.

Switch off the main battery switch (These switches located in engine room)

!

The main battery switches must never be switched off until the engines have stopped.

Should the battery switch be turned off while the engine is running, serious damage to the accelerator can result.

Before leaving the boat check that there is no water leakage. In extreme cold water, if there is risk of icing, drain the cooling water from the engine unless properly protected.

Protect your boat and make theft difficult. Never leave your boat ready for use.

3.11 Safety Equipment

Whether the boat is being used for long cruises or short bathing trips, it should be equipped with safety equipment.

Of course, supplement further according to personal preference. Investigate at regular intervals to ensure that there is safety equipment on board and that it is all in proper working order.

Listed below are for your reference :

Distress Rockets Daytime smoke and night rockets

First aid box Ensure that all personnel know where it is kept

Tools These should be suitable for the type of engine

Anchor & Chain Make sure there is an adequate length of line

Chart Of the area you cruising

On board engine spare parts

Mooring rope

Foghorn

Boat hook

Fenders

Torchlight

Radio

Compass Ensure that this has been corrected also that you have the correction card on board.

Life jacket For all, onboard

Fire extinguisher This must be approved and suitable type. At least one must be fitted & installed in an easily accessible position. Ensure all crew and passengers are familiar with the operating instructions.

3.12 Etiquette

Never throw rubbish or refuse overboard

Always proceed slowly when passing a ship when in crowded waters or when passing equipment where drivers may be working.

Never make a nuisance of yourself with the horn, searchlight or radio and do not pass too close to swimmers.

Recognize elementary distress signals and never pass a ship in distress.

Kept an alert look out. Serious personal injury or damage to a boat can cause through negligence.

3.13 Useful Information

Boat Speed and Engine Efficiency

Speed depends on many variable factors and therefore no catalog or advertised speed can be guaranteed. Some of the factors affecting boat speed are presented below.

(1) Atmospheric Condition

Engines will develop more power when the ambient air and water temperatures are cooled. Power variations due to temperature can be as much as 10% and for this reason greater speed are generally obtained in spring and autumn, rather than in the summer.

(2) Personal Equipment and Accessories

All personal equipment, accessories and extra passengers will tend to decrease the speed. Often the effect of this added weight is not taken into consideration when the performance of the boat.

(3) Marine Growth

In order to obtain maximum speed, the bottom of the boat must be kept free of marine growth, including moss. Any growth on the boat's bottom will significantly increase the resistance of the boat as it move through the water and thus decreased the speed. The use of a good anti fouling paint is advised.

(4) Damage Underwater Equipment

Loss of speed and excessive vibration can result from damaged propellers, shaft or struts. If it occurs have this investigated immediately.

With normal care and maintenance, the engine will maintain peak efficiency. However, if they are neglected, the power will fall off and expensive repairs may become necessary.

3.14 Instrument

Engine Instrument

Your TAYANA48DS has several sets of performance gauges mounted on the instrument panel. These gauges will help you aware of the statue of the engine system. Please refer to "Engine Operation and Maintenance Manual " for detail.

3.15 Tachometer

The tachometer indicates the engine speed in revolutions per minute (RPM). This is the most important instrument fitted to the boat. You should set your running speed with reference to the RPM. You will have a continuous indication of the efficiency of your engines and propellers.

3.16 Temperature Gauge

The temperature gauge indicates the running temperature of the engine, it is important to monitor this instrument as it is quite common for the water intake to draw up an obstruction such as plastic bags etc. Most engines are fitted with an overheat alarm. You must react very quickly, turn engine off immediately and investigate.

(The location of all sensors please refer to “Engine Operation and Maintenance Manual”)

3.17 Oil Pressure Gauge

The oil pressure gauge indicates the oil pressure in the engine, again it is important to monitor this instrument. Most engines are fitted with oil pressure alarms.

Please refer to engine handbook for normal oil pressure information. You must react very quickly, turn engine off immediately and investigate.

3.18 Gear Box Oil Pressure

Abnormal gearbox pressure will damage the gearbox. These should monitor closely as they work to a very high pressure. Please check the specification for correct working pressure. You must react very quickly, turn the engine off immediately and investigate.

3.19 Hour Meter

The hour meter operates only when the engines are running and

records the total running hours. Refer to the engine handbook for service intervals that are given in terms of hours run.

3.20 Alarm System

Located at the control console. The buzzers are audible from almost anywhere on the boat.

3.21 Ammeter

There are AC and DC meters fitted on board. And they are located in AC and DC electrical panels.

3.22 Voltmeter

Voltmeters are fitted in AC and DC 12 volts electric panel. Please refer to attach wiring diagram for details. (Charging system)

3.23 Troubles Shooting

The following chart will assist you in finding and correcting minor mechanical and electrical problems with your boat.

3.23.1 Engine and Power Train

NOTE :

For further trouble shooting information other than given here, please refer to the engine owner's manual.

PROBLEM

Engine will not start.

POSSIBLE CAUSE

- (1) Fuel valves are closed or fuel tanks are empty
- (2) Contaminated fuel
- (3) Stop solenoid energized
- (4) Loose wiring or bad key switch
- (5) Main and, or ignition circuit breaker are OFF

SOLUTION

- (1) Check fuel valves or fill tanks.
- (2) Check fuel for contaminants or water. If fuel is contaminated, drain the tanks and fuel lines, flush with clean fuel and replace fuel filters and bleed the system.
- (3) De energize stop solenoid.
- (4) Look for any loose connections. Contact technicians to replace switch if necessary.
- (5) Turn all breakers and main switch ON.

PROBLEM

Low start speed.

POSSIBLE CAUSE

Weak or bad battery

SOLUTION

Have battery tested or charged.

PROBLEM

Starter will not turn engine crankshaft

POSSIBLE CAUSE

- (1) Corroded battery terminals
- (2) Loose wiring connections
- (3) Weak or discharged battery
- (4) Defective starting switch

SOLUTION

- (1) Clean terminals
- (2) Clean and tighten all wire connections
- (3) Charge battery
- (4) Contact authorized dealer for switch replacement

PROBLEM

Lack of power

POSSIBLE CAUSE

- (1) Throttle not fully open
- (2) Contaminated fuel

SOLUTION

- (1) See authorized dealer for throttle linkage adjustment
- (2) Drain fuel tanks and lines, flush with clean fuel and replace fuel filters

PROBLEM

Erratic engine speed

POSSIBLE CAUSE

- (1) Pinched or clogged fuel lines or vent line
- (2) Contaminated fuel

SOLUTION

- (1) Replace line or remove obstruction
- (2) Drain fuel tanks and lines, flush with oil and replace fuel filtersclean fuel

PROBLEM

Engine overheat

POSSIBLE CAUSE

- (1) Engine cooling water sea cock closed or water pick up is blocked at intake screen
- (2) Leaking or pinched water line
- (3) Low coolant level
- (4) Broken raw water pump or impeller
- (5) Block heat exchanger or transmission oil cooler
- (6) Fault thermostat

SOLUTION

- (1) Open sea cock or remove obstruction
- (2) Repair or replace water lines

- (3) Refill with fresh water check for cause of flow level
- (4) Remove back of pump and inspect, replace if necessary.
Be sure all broken parts are removed
- (5) Remove end plates of heat exchanger and check for foreign matter
- (6) Remove fresh water reservoir and lift out thermostat

PROBLEM

Transmission shifts hard

POSSIBLE CAUSE

Corroded or pinched linkage

SOLUTION

Replace or lubricate linkage as necessary

PROBLEM

Excessive vibration

POSSIBLE CAUSE

- (1) Foreign objects obstructing the propeller
- (2) Bent propeller or shaft
- (3) Engine and shaft are misalignment
- (4) Engine not timing properly or misfiring
- (5) Bent rudder
- (6) Worn strut, engine or transmission bearing
- (7) Engine to shaft coupling out of round or off center

SOLUTION

- (1) Remove objects from propeller, shaft or rudder by reserving propeller or cutting and pulling away obstruction.
- (2) Replace propeller or shaft as necessary
- (3) Check engine and shaft alignment. Alignment must be within 0.003 inch
- (4) Have engine tuned by authorized dealer
- (5) Replace rudder
- (6) Bearing replaced by authorized dealer
- (7) Have coupling checked by an authorized dealer

PROBLEM

Poor performance

POSSIBLE CAUSE

- (1) Boat is overloaded or weight is badly distributed
- (2) Materials wrapped around the propeller
- (3) Damaged or use of wrong propeller
- (4) Boat hull has marine growth on it or hull is damaged
- (5) Excessive bilge water
- (6) Engine is misaligned

SOLUTION

- (1) Reduce overloaded or distribute load evenly
- (2) Run propeller in reverse or cut and pull materials from propeller

- (3) Inspect propeller, replace as necessary
- (4) Clean or repair hull as necessary
- (5) Pump water out and inspect hull for leaks
- (6) Have engine alignment checked by an authorized dealer

3.23.2 Electrical

NOTE :

For any trouble shooting information other than provided here, please refer to the individual components owner's manuals.

!

Never reset a circuit breaker that has been automatically tripped without first location and correcting the problem

PROBLEM

Electrical equipment will not function

POSSIBLE CAUSE

- (1) Circuit breaker in the tripped or Off position
- (2) Weak or discharge battery
- (3) Loose or broken wire connection

SOLUTION

- (1) If breaker is tripped, correct the problem and reset;

otherwise, turn circuit breaker ON

- (2) Charge battery
- (3) Connect or repair wire as necessary

PROBLEM

Lights do not come on or are dim

POSSIBLE CAUSE

- (1) Circuit breaker in the tripped or OFF position
- (2) Weak or discharged battery
- (3) Loose or broken wire connection
- (4) Light bulb burned out

SOLUTION

- (1) If breaker is tripped, correct the problem and reset; otherwise, turn circuit breaker ON
- (2) Charge battery
- (3) Connect or repair wire as necessary
- (4) Replace bulb

PROBLEM

Generator will not start

POSSIBLE CAUSE

DC main switch in OFF position

SOLUTION

Turn main switch ON

PROBLEM

No power at AC outlets

POSSIBLE CAUSE

Ground fault circuit interrupter tripped

SOLUTION

Reset button on outlet and test. If reset button or light does not come on, DO NOT use any outlets. Have circuit checked by qualified technician.

3.23.3 Plumbing

NOTE :

For any trouble shooting information other than provided here, please refer to the individual equipment owner's manual

!

Never reset a circuit breaker that has been automatically tripped without first locating and correcting the problem

PROBLEM

No water at shower or sinks when faucet is turned on

POSSIBLE CAUSE

- (1) Fresh water pump circuit breaker tripped or OFF
- (2) Fresh water tank is empty

- (3) Pump is defective

SOLUTION

- (1) If breaker is tripped, correct the problem and reset; otherwise, turn circuit breaker ON
- (2) Fill fresh water tank
- (3) Have pump serviced

PROBLEM

Low water pressure at all shower and sinks

POSSIBLE CAUSE

- (2) Water system has lost its charged
- (3) Weak or worn pump

SOLUTION

- (1) Check for leaks in water system or air leaks in accumulator
- (2) Have pump serviced

PROBLEM

Low water pressure at only one shower or sink

POSSIBLE CAUSE

Restriction or obstruction in water line

SLUTION

Clean, repair or remove obstruction from water line.

3.23.4 Windlass

!

Stay clear of the windlass while it is being operated

IT IS ADVISABLE TO SWITCH THE MAIN BREAKER SWITCH OFF IF WINDLASS IS NOT IN USE.

IT IS IMPORTANT TO CONNECT A SAFETY LANYARD TO THE ANCHOR WHEN USING THE BOAT AT HIGH SPEED.

PERIODICALLY CHECK THAT THE CLUTCH OF THE WINDLASS IS FULLY TIGHTENED.

To operate the windlass the ON/OFF switch must be on.

Before lowering the anchor first check the suitability of the anchorage. Disconnect the safety lanyard from the anchor. Turn on the main switch and breaker. Normally the amount of chain required is 2-3 times the depth of water below the boat. To raise the anchor reverse the operation, when the anchor returns to the bow roller it will automatically guide itself into its parked position. It is important to connect a safety lanyard to the anchor. Neglecting to do so could result in the anchor running free and causing serious damage to the propellers and under water gear.

If the windlass is overloaded or jammed the main switch will cut out automatically. Be extremely cautious when resetting the breaker, free any obstruction from the windlass.

!

THE SAFE OPERATION OF AN ELECTRIC

WINDLASS REQUIRES EXTREME CAUTION. KEEP CLEAR OF CLEAR OF MOVING PARTS AT ALL TIMES. REFER TO THE MANUFACTURER'S OWNER'S MANUAL FOR INSTRUCTION ON THE SAFE AND PROPER OPERATION OF THE WINDLASS.

!

NEVER HANDLE CHAIN ON THE WINDLASS WITH ELECTRIC POWER SUPPLIED TO THE WINDLASS. TO CLEAR FOULED CHAIN, ALWAYS DISCONNECT ELECTRIC POWER FIRST.

3.23.5 Windlass Maintenance

To maintain your windlass in like new condition, you should rinse liberally with fresh water often. Polish the case and all exterior parts periodically. A fitted canvas cover will help minimize exposure to salt water.

Periodically check the oil level of windlass and fill as needed. Please refer to the manufacturer's owner's manual for complete maintenance guidelines.

3.23.6 Bow Thruster

To operate the bow thruster the ON/OFF switch must be on.

!

Important User Precaution

Ensure that you know the location of the main battery switch that disconnects the thruster from all power source (batteries) so that the thruster can be turn off in case of a malfunction.

Always turn the main power switch off because touching any part of thruster, as an incidental start while touching moving parts can cause **serious injuries**.

Always turn the control device off when the thruster is not in use.

The maximum continued usage time of the electrical thruster is approximately 3 minutes. The electric motor has a built in thermal cut-off switch that will shut off the electric motor if it is overheating and re-engage it when it has cooled down some. This should be considered when planning your maneuvering.

This also means that the thruster will limit its total running time per time period so that you cannot count on thruster to hold you in current and side wind for extensive periods. Depending on the surrounding temperature etc., the thruster will be able to run approximately 10% of the time.

Never use a thruster close to somebody in the water, as the thruster will draw objects close by into tunnel and contact with rotating propeller will cause serious injuries.

Never run a thruster when the boat is not in the water, as this can damage the electric motor seriously. If the thruster stops giving thrust while the electric motor is running, chances are that there is a problem in the drive system. You must then immediately stop trying to run it and turn it off.

Running the electric motor for more than a few seconds without resistance from the propeller, can cause serious damage to the electric motor.

When leaving the boat always turn off the main switch for the thruster.

We advise to always keep the main engines running while using a thruster. This will keep the batteries in a good charge condition.

This will also give better performance to the thruster, as a higher

voltage at the thruster results in a higher torque in the electric motor.

Please note that the performance of a thruster strongly depends on the voltage available at the electric motor. This voltage will decrease by time because aging batteries have reduction of capacity. By installing new batteries the effect of thruster should be back at original level.

Make sure that only one control is used at the same time. If two panels are operated in opposite direction at the same time the thruster will not run at all. If they are operated in the same direction the thruster will run in this direction.

If the thruster is not performing properly or functioning as usual, the cause for this must be found and corrected as soon as possible to avoid causing further damage to the equipment.

You must also turn off the main battery switch immediately in case the problem is electric in origin.

!

How to use a bow thruster

- (1) Turn main power switch for the bow thruster on. (Always turn off the main power switch when not on board)
- (2) Please take some time to exercise thruster usage in open water to avoid damage to your boat.
- (3) Turn the control panel on by pushing both "ON" buttons on the side-power panel simultaneously.

CAUTION !

Power turns off automatically after a time and must be turned on by pushing both on buttons.

- (4) Turn the bow in the desired direction by pushing the red button for port movement or the green button for starboard movement. If you have a joystick control, move it in the direction you wish the bow to move.

- (5) Depending on the sideway speed of the bow, you must disengage the control device shortly before the bow is in the desired direction, as the boat will continue to move after stopping the bow thruster.

!

Maintenance

There must be oil in the oil reservoir. Refill if necessary.

Change the gear oil a minimum of every second year. Check the gear oil quality in the gear house every time the boat is out of the water.

Retighten the bolts holding the gear house to the motor bracket during the first on land service with the specified bolt tightening force. Refer to Bow thruster manual.

Keep the propeller and gear house clean from growth by planning with anti fouling before every season.

The zinc anode, sealing and propeller shafts must absolutely not be painted. Be careful that you do not fill paint in the “tracks” in the gear housing the propeller hub moves in.

Change the zinc anode before every season, or when about half the anode is gone. Always use a sealant on the screw holding the zinc anode to ensure that it does not fall off. Please observe that in some water conditions it can be necessary to install an extra zinc anode to ensure that it lasts for the period between regular services of the boat.

As a part of the season service of your boat and before every season, always check that :

The propeller is securely fastened.

The bolt holding the electric motor to the motor bracket are

tightened correctly.

The area where the thruster is installed is clean and dry. If there are signs of water you must try to find the source and eliminate it.

All electrical connections are clean and fastened firmly.

Make sure that your batteries are in a good condition so that the thruster gets a good voltage. Old or bad batteries will give a reduced performance from the thruster.

Trouble Shooting

PROBLEM

The electric motor runs, but there is no thruster

Check

If the flexible coupling between the motor and drive shaft is not fitted correctly inside the boat.

Solution

Check the flexible coupling and the motor installation to ensure correct connection of the flexible coupling before refitting the electric motor.

Check

Is the propeller in the tunnel fastened correctly on the propeller shaft.

Solution

Re-fasten or replace the propeller or key.

Check

With the motor removed, turn the drive shaft from inside the boat to feel if the gears are engaging and turning the prop shaft.

Solution

In case of a failure inside the gear house, we advise to get a replacement gear house instead of attempting to

repair the internal gear and bearing system.

PROBLEM

The thruster does not start at all or works only in one direction

Check

Check that the voltage of the electric motor is correct for your installation by their labels.

Solution

If wrong, contact your dealer or distributor to obtain parts with the correct voltage.

Check

Check the voltage at the thruster between main minus input and main plus input point.

Solution

The no load voltage should be 12-V system, if below 10.4-V your batteries are not in good charge state or worn out and must be recharged and replaced before trying to run the thruster.

Check

Check the voltage at the thruster while you are trying to run it. Keep main engine running to have continuous charged to the batteries.

Solution

In a 12-V boat the thruster will operate down to approx. 10.5-V, but the performance will be very poor. Find and correct the reason for the low voltage which may be one or more of these points. Main batteries cable connections, battery size and condition, fuse and main power switch performance.

Check

If the main solenoids on the thruster are not trying to engage (click) they are probably not getting a “run” signal from the control system. Try to run the thruster without the panel by directly connecting the red and blue

or the red and gray wires in the control cable contact coming from the thruster.

Solution

If the thruster runs in both directions, try the same in the connector that goes into the back of the control panel. If it also works in this position, check the contact and wires on the back of the panel and try to engage this again by pushing both ON buttons simultaneously. If the panel does not turn on, measure the voltage between the red and black in the contact going into the thruster. If the voltage is good, chances are that the panel is not working. If it works by the thruster and not by the panel there is a bad contact or a broken lead the control cables between these two points.

Measure that you have the correct voltage between the red and all other colors in the contact.

Check

If the thruster does not run at all or only in one direction in the above tests, check the internal wiring on the thruster motor, solenoids and electric motor interface box to be accordance with the wiring diagram and ensure that all connections are clean and tight

Solution

Between main minus and the blue and gray wire connected to the sides of the main solenoids you should have the same voltage as between the main battery cables on the thruster. If not, check that the internal wiring on the solenoid is okay and measure that there is contact through the magnetizing spools of each side of the solenoid (measure between the red and blue on one side and red and gray on the other side with an ohm meter). If there is no contact between these, the solenoid is broken and needs replacing.

PROBLEM

The thruster has an unexpected low performance

Check

Check voltage at thruster when running

Solution

If less than 10.5-V the thruster will not perform at specified effect

Check

Check that all the brush spring sits correctly on the brushes in the electric motor

Solution

If one or more brushes are loose/has no tension from the brush spring, the performance will be low

Check

Check that the propeller, gear house and tunnel is free from growth/barnacles etc.

Solution

If there is growth in the tunnel, this will disturb/block the water flow and especially barnacles on the propeller will greatly reduce performance.

3.23.7 Generator

Generator Operation

The panel controlling generator operation is on the AC electric panel located in the nav. station. Generator starting battery is 12-volt system. Capacity of this battery is 120 AH.

Before Starting the Generator

Before operating generator become familiar with the procedures and instructions in the generator manufacturer's owner's manual

- (1) Follow the pre-start checks as outlined in the generator manual
- (2) Ensure the AC power select switch is not on GEN. Positions
- (3) Check that generator sea cocks are open
- (4) Check the generator lubrication oil level

- (5) Check the fuel supply and fuel return valves are set properly

Starting the Generator

- (1) Set the battery ON/OFF switch to the ON position.
- (2) Press the START/STOP/WARM UP switch down into the STOP/WARM UP position for up to maximum seconds specified by the manufacturer's manual.
- (3) Depress the START switch for maximum number of second specified in the generator operator manual or until the generator starts
- (4) Release the START switch
- (5) Be sure that salt water is flowing from the exhaust outlet on the transom corner. If there is no flow of water, to avoid damaging your generator, immediately shut if off until you solve this problem.

!

If the generator does not start after several tries, its water lift muffler may fill with water. To keep salt water out of the generator exhaust manifold, remove the muffler drain plug to empty the muffler.

!

When starting your generator, do not exceed the maximum seconds of warm up or maximum seconds of cranking specified in the generator manufacturer's operator's manual. Wait 2 to 3 minutes before trying again.

Using Electric Power from your Generator

- (1) Allow the generator to run few minutes before switching to a load.
- (2) Make a visual inspection of generator and listen for any unusual sound.

- (3) Set the select switches to GEN
- (4) Set the circuit breakers for the desired appliances and equipment to ON or OFF

NOTE :

Keep clear of any moving parts or any machinery while it is operating.

NOTE :

Never rotate the select switches under load.

Stopping the Generators

- (1) Turn off all AC breakers
- (2) Rotate AC select switches to the OFF position.
- (3) Press STOP switch and hold until generator stops.

!

AC electric power can be dangerous. Do not attempt to service a system unless you are thoroughly familiar with and experienced in performing such services. Do not forget to turn off all AC power source before attempting repair.

DO NOT FORGET THE INVERTER !

3.23.8 Shore Power

Your TAYANA48DS has two 220-volt AC power inlets, Connecting either shore cords provides your vessel's 220 volt AC power. Each inlet and circuit breaker is rated at 30 amperes.

!

Each shore inlet is rated at 50 Amperes. To protect

your inlet fittings from damage and to prevent the inlet circuit breaker from tripping, do not exceed 30 Amperes current draw.

!

Never rotate the shore power select switch under load.

3.23.9 Battery Charger

The on board AC to DC battery chargers change 220 V AC input into 12V DC and 12 C DC output to charge the battery banks. When the batteries are fully charged, the charger maintain a trickle charge condition. These chargers are sophisticated, multi stage chargers and require little maintenance. Please read the owners manual provided.

It recommends that the chargers normally be left in the ON position with either shore power or the generator supplying the power. Battery charge system schematic is as drawing attached.

ENVIRONMENT

- Do not pour oil overboard; use appropriate waste containers.
 - When you fill up the engine fuel tank, take all the precautions in order to avoid overflowing
 - In the harbor, do not use the heads if they are not flush to the holding tank.
 - The use of detergent contributes to the deterioration of the sea fauna and flora choose entirely biodegradable products for your cleaning operation.
 - Do not throw plastic bags overboard
- You love the sea, just as we do; therefore, help us to protect it and do not pollute it

Maxwell Winches Installation Inspection Form

Name of builder : TA YANG

Date of Inspection : JUNE-06-2007

File #

Name of Inspection :

Boat Size :48FT

Hull # :48-101

Vessel Type : power :

Sail : V

Vessel Displacement:

Beam :

Height at water line :

Maxwell Dealer Name : Mercury Marine Supply Co., Ltd

vessel classification

Address : No.15 Chongshan St . Siaogang District ,

sold to Dealer Name:

Kaohsiung , 812 , Taiwan

Address :

A) Above Deck Installation

Port Windlass

STBD Windlass

Port Capstan

STBD Capstan

VWC2200/12VDC,CW

- 1) Correct size for boat
- 2) Aligned correct
- 3) Footswitches correct location
- 4) Footswitches breather holes clear
- 5) Clutches grease
- 6) Main bearing grease
- 7) Chain stopper/snubber installed
- 8) Correct bow roller for chain
- 9) Chain size and Length
- 10) Chain Type (short or stud)
- 11) Chainwheel Number
- 12) Mooring Line Diameter
- 13) Anchor Weight
- 14) Comments and Recommendations

V

V

V

V

V

V

V

V

3/8"H.T

short

58

B) Below Deck Installation

- 1) Motor clear of chain
- 2) Chain clear of deck and chain pipe
- 3) Wires clear and source
- 4) Chain locker clear of obstructions
- 5) Chain storage sufficient for rod
- 6) Bitter end secured
- 7) Winch Serial Number
- 8) Comments and Recommendations

V

V

V

V

V

V

G7180

Maxwell Winches Installation Inspection Form

C) Control Equipment	Port Windlass	STBD Windlass	Port Capstan	STBD Capstan
1) Voltage / Frequency	_____	_____	_____	_____
2) AC controller	_____	_____	_____	_____
3) Power down control	_____	_____	_____	_____
4) Solenoid control box	V	_____	_____	_____
5) Controls installed in dry location	V	_____	_____	_____
6) Wired correctly	V	_____	_____	_____
7) Breaker isolator	135AMP	_____	_____	_____
8) Isolator correctly located	V	_____	_____	_____
9) Control circuit fuse fitted	V	_____	_____	_____
10) Control fuse accessible and dry	V	_____	_____	_____
11) Motor cables correctly sized	V	_____	_____	_____
12) Control cables correctly sized	V	_____	_____	_____
13) Battery voltage at supply	13.69V	_____	_____	_____
14) Voltage at winch motorwhile running	11.82V	_____	_____	_____
15) Hydraulic pressure	_____	_____	_____	_____
16) Hydraulic flow	_____	_____	_____	_____
17) Hydraulic hose size	_____	_____	_____	_____
18) Comments and Recommendations	_____	_____	_____	_____

D) General

1) Mounting bolts greased and tightened	V	_____	_____	_____
2) Electrical terminals all tight	V	_____	_____	_____
3) Electrical terminals protectively coated	V	_____	_____	_____
4) Cover / protection of windlass	V	_____	_____	_____
5) Windlass operating correctly	V	_____	_____	_____
6) Chrome plating to standard	V	_____	_____	_____
7) Clutch handle	V	_____	_____	_____
8) Owners manual on vessel	V	_____	_____	_____
9) Cover/protection for winch shipping	V	_____	_____	_____
10) Comments and Recommendations	_____	_____	_____	_____

Singed by : *KEVIN LIU*

Singed by :

Mercury Marine Supply Co., Ltd

Builder

華立企業股份有限公司

WAH LEE INDUSTRIAL CORPORATION

高雄市中正四路二三五號十樓

10F.#235.CHUNG CHENG 4 TH ROAD.

KAOHSIUNG. TAIWAN. R.O.C.

YANMAR ENGINE RUN TEST REPORT

CUSTOMER: TA-YANG YACHT BUILDING CO., LTD. (大洋)
BOAT SIZE: D48-101
ENGINE SERIAL NO.: E20218
ENGINE MODEL: 4LH4-HTE X KM4A2 (ratio: 2.63/1) 00346
TEST DATE: 6.JUN.07
RUN TEST TIME: 30 MINETES
SERVICE ENGINEER: LIKY CHANG

A. PREPARATION:

1: LUB OIL IN OIL SUMP: SUFFICIENT
2: FRESH WATER IN HEAT EXCHANGE: SUFFICIENT
3: INSTALLATION OF FLEXIBLE MOUNTS: WELL
4: INSTALLATION OF SUB. TANK: INSTALLED
5: CONTROL CABLE: LAY UP IN GOOD WAY
6: MIXING ELBOW POSITION: BELOW THE WATER LINE EQUIPPED
THE VACUUM VALVE WHICH INSTALLED
THE ELBOW OF THE COOLING WATER LINE

B: START UP:

1: IDEL SPEED: 800 RPM
2: MAX. NO-LOAD SPEED: 3800 RPM
3: COOLING WATER TEMP.: 75 °C
4: LUB OIL PRESSUE: 0.2 MPa
5: TRANSMISSION FUNCTION: WELL

C: REMARK:

1: DURING OPERATION CHECK ENGING NOISE, EXHAUST, TEMP.,
AND VIBRATION ETC, ALL IN GOOD CONDITION.
2: RUN TEST THE ENGING AT TA YANG'S FACTORY, NOT SEA TRIAL.
3: EQUIPMENT IS INSTALLED CORRECTLY, SO WARRANTY APPLIES.

GENERATOR RUNNING TEST & PROPERLY INSTALLATION INSPECTION REPORT

Boat Size & Hull No.: TAYANA-48-101
 Generator Manufacturer: WESTERBEKE CORP.
 Generator Model: J7BTD
 Generator serial No.: J307K
 Generator Model: _____
 Generator serial No.: _____
 Electrical Test: _____

Date: 06/06/07

Unit No.	No load		Fuel Load		Oil Press P.S.I	Water Temps of	Batt Chg Volt	Remote Start & Stop	Fault Shutdown	Running Time
	Volt	Hz	Volt	Hz						
1	220	63			40	170	14.1	OK	OK	22H

Item Generator	No. 1 system	OK/Suggestion	No. 2 system	OK/suggestion
Generator Mounting		OK		
Sound Shield		OK		
Muffler		OK		
Exhaust Line		OK		
Fuel Line		OK		
Water Hose		OK		
Battery Cable		OK		
Wiring		OK		
Grounding		OK		
Ventilation		OK		
Instructions:		OK		

We certify that the above generator have installed correctly and properly as out installation manual instruction and running tested as reported

Inspected and report by qualified engineer inspector:

[Signature]
 Taiwan