

INSTALLATION OF GFO® MARINE SERVICE PACKING IN STERN TUBE AND RUDDER POSTS

Installing GFO® marine service packing is much easier than conventional packing. There are, however, several important tips that will help you get longer, trouble-free service from GFO® marine service packing.

- 1) ***BE SURE PACKING IS PROPER SIZE.*** Oversize will cause packing to burn out, and undersize will leak excessively.
- 2) ***NEVER ROLL OR "HAMMER" GFO® MARINE SERVICE PACKING.*** This damages the fiber and can cause premature failure.
- 3) ***ALWAYS TIGHTEN PACKING SLOWLY.*** Overtightening can cause overheating.
- 4) ***ALWAYS USE HIGH-QUALITY BRAID.*** Three or four track interbraid construction is best.
- 5) ***DO NOT GREASE GFO® MARINE SERVICE PACKING.***

Following these instructions will allow you to get the maximum service life from GFO® marine service packing.

The importance of packing the stuffing box correctly cannot be overemphasized. Many packing failures are due to incorrect installation of the packing. The following steps have been devised to ensure effective installation of packings:

- 1) ***REMOVE ALL THE OLD PACKING FROM THE STUFFING BOX.*** Clean box and shaft thoroughly and examine shaft or sleeve for wear or scoring. Replace shaft or sleeve if wear is excessive.
- 2) ***USE THE CORRECT CROSS-SECTION OF PACKING OR DIE-FORMED RINGS.*** To determine the correct packing size, measure the diameter of the shaft (inside the stuffing box area if possible) and then measure the diameter of the stuffing box (to give the OD of the ring). Subtract the ID measurement from the OD measurement and divide by two. The result is the required size. **CUT -- DON'T WIND.**
- 3) ***WHEN USING COIL OR SPIRAL PACKING, ALWAYS CUT THE PACKING INTO SEPARATE RINGS.*** Never wind a coil of packing into a stuffing box. Rings can be cut with butt (square) or skive (or diagonal) joints, depending on the method used for cutting. The following illustration shows these methods of preparing bulk packaging. The best way to cut packing rings is to cut them on a mandrel with the same diameter as the shaft in the stuffing box area. If there is no shaft wear, rings can be cut on the shaft outside the stuffing box.

Hold the packing tightly on the mandrel, but do not sketch excessively. Cut the ring and insert it into the stuffing box, making certain it fits the packing space properly. Each additional ring should be cut in the same manner.

IMPORTANT:

ALWAYS CUT EACH RING ON A MANDREL IN ORDER TO GET THE PROPER JOINT ANGLE.

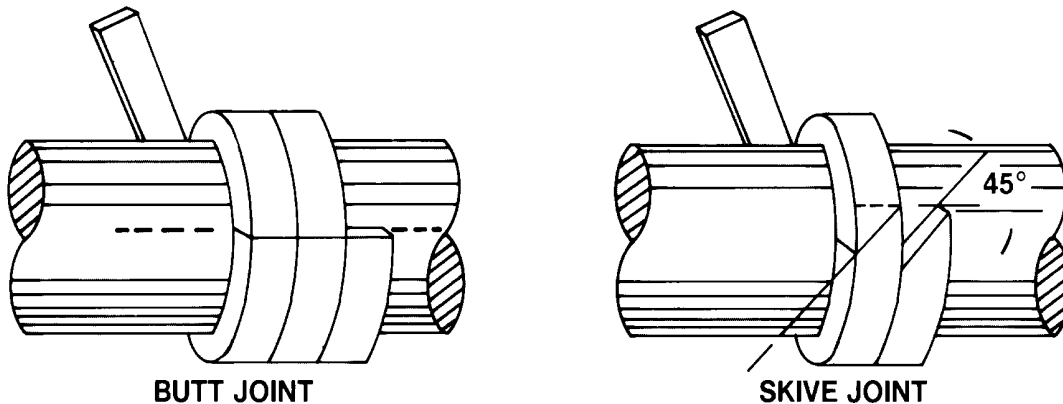

It is necessary that the rings be cut to the correct size and that the joints meet completely.

- 4) ***INSTALL ONE RING AT A TIME.*** Make sure it is clean and has not picked up any dirt in handling.

Seat rings firmly. Joints of successive rings should be staggered and kept at least 90° apart. Each individual ring should be firmly seated with a tamping tool. When enough rings have been individually seated so that the nose of the gland will reach them, individual tamping should be supplemented by the gland.

- 5) ***AFTER THE LAST RING IS INSTALLED,*** take up bolts finger tight. Do not jam the packing into place by excessive gland loading. Make sure gland bolts are taken up evenly. ***STOPPING LEAKAGE ENTIRELY AT THIS POINT WILL CAUSE THE PACKING TO BURN UP.*** Run the vessel for 5-10 hours and readjust packing to get desired leakage.
- 6) Inspect packing on a regular schedule to be sure leakage rate is maintained.