

FLEMING SELF STEERING SYSTEMS

INSTALLATION, OPERATION and MAINTENANCE MANUAL

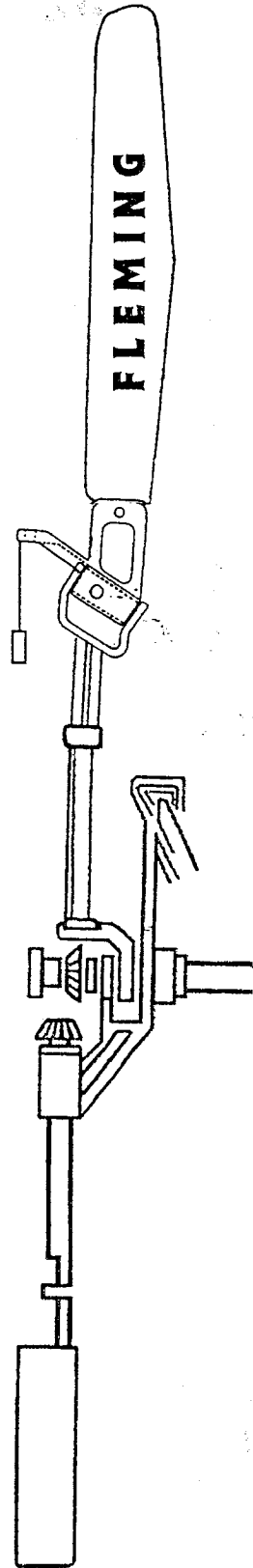

TABLE OF CONTENTS

Section 1	
Introduction	Page 2
Brief History	Page 2
Fleming Servo Pendulum System	Page 3
Fleming Servo Rudder, a Look at Apparent Wind, Diagram A	Page 3-4 Page 5
Section 2	
Sailing and Your Fleming Wind Vane	Page 6
Wind Forces, Diagram B	Page 7
Sailing and Your Fleming Wind Vane continued	Page 8
Yacht Sailing Down Wind, Diagram C	Page 9
Sailing Check List	Page 10
Section 3	
Wind Vane Assembly Instructions	Page 11
Side Elevation of Main Servo Shaft, Diagram D	Page 12
Installing the Unit	Page 13
Installation, Diagram E	Page 14
Installation of Mounting Tubes, Diagram F	Page 15
Section 4	
Installing Control Lines From Unit To Wheel Or Tiller	Page 16
Control Line Installation, Diagram G	Page 17
Mounting and Control Lines, Diagram H	Page 18
Fitting Detail For Wheel Drum To Steering Wheel	Page 19
Photographic Examples of Various Installations	Page 20-21
Section 5	
Mizzen	Page 22
Emergency Rudder Assembly	Page 23
Auto Pilot Add On	Page 24
Appendix	
Construction Details	Page 26
Parts List	Page 27
Part Locations	Page 28-29
Warranty Information	Page 30

INTRODUCTION

Congratulations and thank you for choosing a Fleming Self Steering System. You are about to welcome aboard a fine addition to your crew. It will never get seasick, will always stand watch without complaint, will never invade your quiet space, and can follow you from boat to boat.

It is built Fleming-smart, and Southern Ocean-strong for a lifetime of reliability and service. We have pioneered the use of cast marine grade stainless steel in our units, gaining an enviable reputation for creating the strongest units ever built. Our current design is the third generation. It is the sleekest, strongest and lightest yet. The three-point mounting system ensures that the torque load is distributed evenly across the transom to safely steer vessels as large as 70 feet in length.

Upon delivery, we urge you to take time to learn how it works, carefully noting how best to install it on your boat and the maintenance required. Your full understanding at the onset will ensure that the vane will perform its designed function throughout your cruising lifetime and will eliminate future self steering frustrations. Unfortunately, the Fleming cannot serve coffee, yet, some say it will become one with you. Perhaps it will even become your best friend as you sail the oceans of the world with its uncomplaining, silent assistance.

BRIEF HISTORY OF SELF STEERING

We have confined this summary to the mechanical servo system. The field of modern self steering servo systems is quite new. The very first vanes were used to control model sailing yachts during the 1920's in the United Kingdom. The air foil was attached directly to the rudder and seemed to work well. In the 1930's, the first full size unit was fitted to a motor yacht, that crossed the Atlantic. It was not until the 1950's that people really started building and improving self steering for sailing yachts. Things really moved ahead when the Observer Newspaper announced a challenge for a single-handed race across the Atlantic. This race was known as the OSTAR (Observer Single-handed Trans Atlantic Race). This race did wonders for the development of mechanical self steering in a very short time period. All competitors found the need for such a device. An Englishman, Col. H. G. Hasler, is recognized as the first person to develop the modern servo system. The French, not to be outdone, soon developed a design that incorporated a horizontal axis air foil in contrast with Col. Hasler's vertical axis design. The horizontal axis air foil was a marked improvement as the foil movement was proportional to wind change. Modern units still use gears, gudgeons, cams, push rods, etc., to achieve the steering process. We owe a debt of gratitude to these early pioneers, both manufacturers and clients alike, for their innovative ideas. Today, a self steering unit is considered by many to be the most important piece of equipment for long distance, offshore cruising.

THE FLEMING SERVO PENDULUM SYSTEM HOW IT WORKS

At Fleming, we use the “servo pendulum” mechanical self steering system. It is the most widely used type due to its efficient use of the vessel’s main rudder for steering.. Even though servo systems are the most widely used, they are still the least understood. The casual observer might believe the long servo blade attached to the system is a rudder that directly steers the boat. This, in fact, is not the case. The blade is a servo pendulum, hence the name, “servo pendulum system”

Let’s take a look at servo power. Have you ever rowed a dingy? The oar is quite small compared to the dingy, yet it has enough mechanical advantage to move the dingy along quite nicely with little effort. Even at a very slow speed, if you take one oar and put the blade into the water parallel to the flow of the water (feathered), the flow going past it creates very little drag and the dingy continues to move ahead. However, when the oar is rotated even slightly across the flow of water, the increased drag causes a violent sideways thrust, turning the dingy around the oar. The water flowing past the oar creates hydrodynamic energy. That is what it is all about.

A sailing yacht behaves the same way. The “dingy oar” in our example above is the same as the servo pendulum rudder suspended in the water behind the vessel. When vessel is moving and this rudder is rotated on its vertical axis, drag is created and the servo rudder is pushed violently sideways. This pulls on lines attached to the servo pendulum. These lines are connected to the boat’s steering system and steer the boat through its main rudder. The harder the wind blows the boat has more forward motion through the water creating greater hydrodynamic energy, and more servo power is then developed to steer the yacht.

A LOOK AT THE FLEMING SERVO RUDDER

A small air foil is attached to a submersed servo rudder via a push rod mechanism. The air foil rotates around an inclined horizontal axis providing proportional response to any shift in the apparent wind.

There are two types of wind: “true” and “apparent”. True wind is what one feels on their face when standing still, facing into the wind. Let’s say there are 10 units of wind pressure on your face. If you now walk forward directly into the wind at 4 units of forward velocity, you will feel a total of 14 units of wind pressure (a net increase of 4 units). The total pressure is referred to as apparent wind.

If you now make a right turn across the wind still at 4 units of forward velocity, the wind pressure felt on the left side of your face will be the 10 units of true wind (for simplicity in this example, disregard the effect of rapid forward velocity). When turning with your back to the wind and traveling at 4 units of forward velocity, the wind felt on the back of the head would be 6 units of wind pressure ($10 - 4$), still called apparent wind velocity. It is clear the air foil sees less apparent wind and therefore, less wind pressure sailing across and especially downwind on any given day.

When the vessel deviates off its set course, the direction of the apparent wind also changes and the air foil presents one side to the wind. Refer to Diagram A on Page 5. The resulting wind pressure then pushes the air foil sideways around it's inclined horizontal axis, however this is very low power. This then moves the push rod (up or down), driving the gear mechanism and rotating the servo rudder around it's vertical axis. Add the forward motion of the yacht and the hydrodynamic power developed is substantial. The energy developed by the water flowing past the submerged, rotated servo rudder causes it to deflect sideways (dingy and oar example). The faster the vessel moves, the more power is developed. The servo deflection is transmitted to the main steering rudder via control lines to the wheel or tiller. In this way, the main rudder steers the yacht. When the servo rudder has pulled the yacht back on the original course, the apparent wind will then be back to zero and the air foil will stand upright, reversing the push rod movement. The servo rudder feathers and moves back by its own negative buoyancy to it's central position. The vessel will continue sailing uninterrupted for hundreds of miles if the apparent wind and pressure remain constant. When either one changes, only minor adjustments are required to maintain course.

A hull speed of 2.5 knots will operate the Fleming mechanical servo system. When the vessel is on course, the air foil will quiver upright around its vertical position. Every effort should be made to trim the sails in order to balance the boat. There may be a little bias in the wind vane needed to compensate for normal weather helm.

STEERING TO CHANGES IN APPARENT WIND - Diagram A

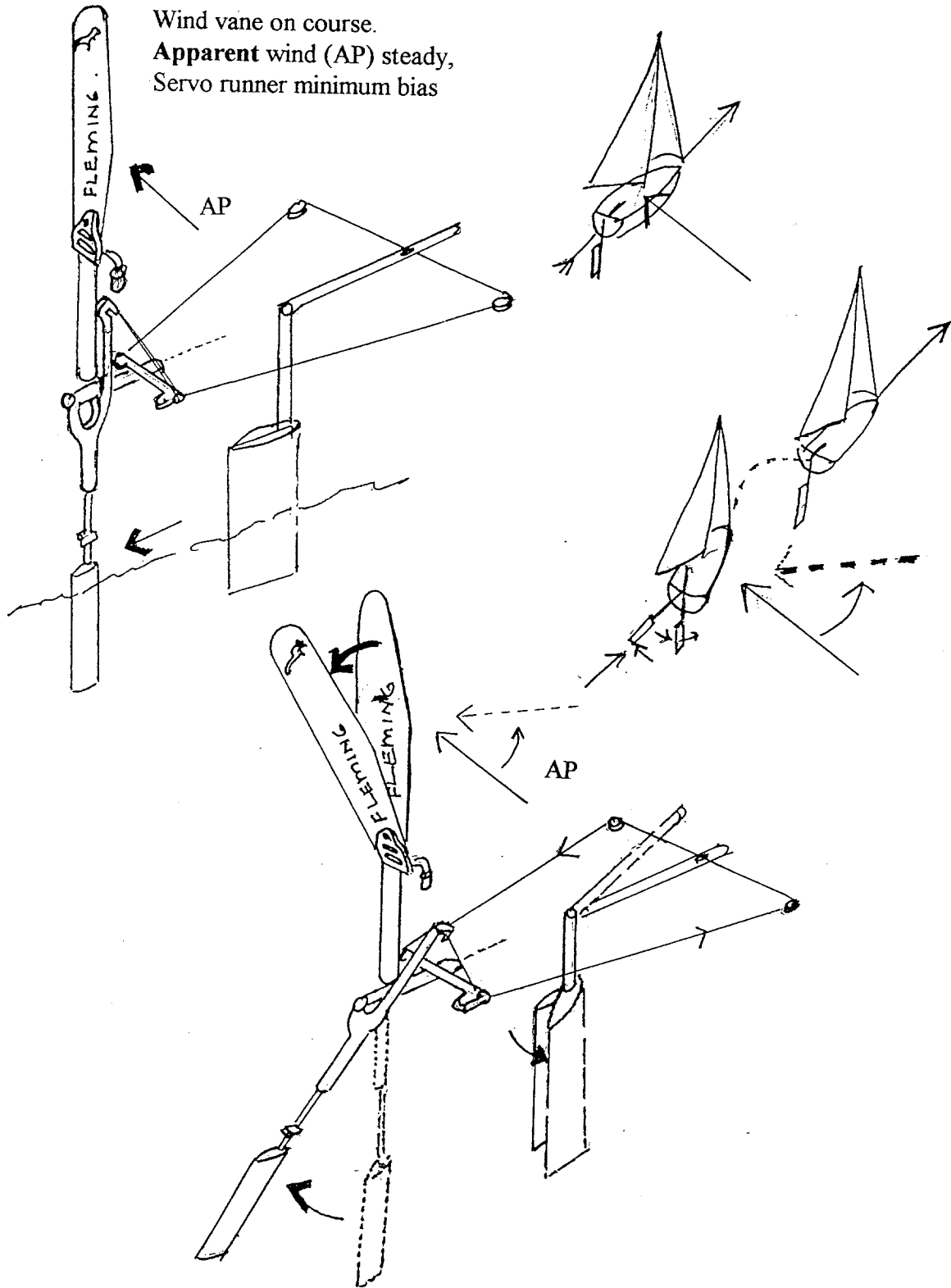

SAILING WITH YOUR FLEMING WIND VANE

Please refer to **Diagram B, the Force Diagrams on Page 7:**

When a yacht moves through the water it is subjected to the following forces, **side slip (leeway)**, **weather helm**, **yawing** and **rolling**. To create a forward motion, a **thrust** (wind pressure on the sails) is required. The hull's **resistance** must equal **thrust** to achieve a steady forward motion. In other words, action equals reaction. As the **wind** pressure increases the relationship between the **thrust** and hull **resistance** remains constant, maintaining a forward motion. However, the **thrust** and hull **resistance** do not act in the same line, so another equal and opposite force is required to keep the vessel sailing on a straight course. The opposite force is the **keel rudder couple** which balances the turning movement of the **thrust resistance couple** allowing the vessel to move ahead with minimum side slip and **rudder** deflection.

As illustrated in the force diagram that if the **wind** pressure increases, an adjustment is required to the **keel rudder couple** to maintain the preset course as the **weather helm** has increased **turning movement** requiring more **rudder deflection**. A better way to reduce the new **turning movement** and maintain the set course without increasing **rudder deflection** is to adjust the sail trim, so the vessel sails more upright. An excessive weather helm is always introduced when driving the vessel too hard. Remember our "go fast" racing days? Rail down, two men on the helm, the rudder stalled and the boat still charged up windward with a mind of its own. In similar circumstances your vane will also lose control.

Therefore when using your new Fleming Wind Vane the following rules apply:

1. When the yacht sails to windward, the sails in the front of the mast tend to push the bow away from the wind direction.
2. When the yacht sails to windward, the sails behind the mast tend to drive the bow up into the wind.
3. When the yacht is running downwind, the same conditions apply but to a lesser extent. As the rudder and keel are nearly in line, with minimal heel, it requires less rudder deflection.
4. Rudder deflection can be further reduced by sailing wing and wing (main and head sail opposite tack), or further improved by using only heads sails to pull the boat through the water. Directional stability is excellent when the rudder is well aft of the sail power, pulling rather than pushing the hull.
5. All vessels behave a little differently; experiment to get the best results from your vane.

FORCE DIAGRAMS - Diagram B

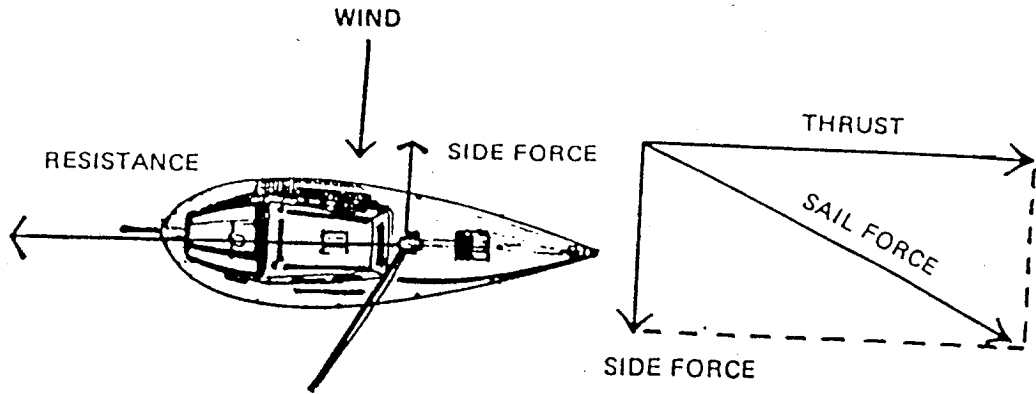

YACHT SAILING WITH UNEQUAL FORCES

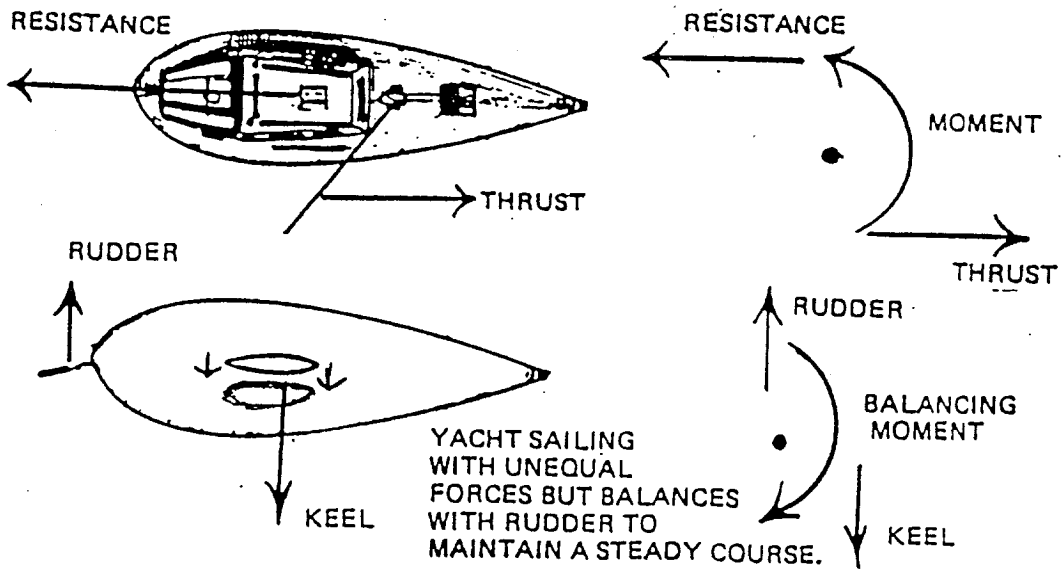

6. Boats with long keels will track well but will pull back on course more slowly. The oscillation across the set course is always a few degrees more for this type of vessel. After hundreds of miles of ocean sailing with the vane controlling the helm, any noticeable track deviation will not be a factor.
7. Vessels with short keels and aft hung rudders track extremely well and react very quickly to the "helmsman" or wind vane signal.
8. Regardless of boat type, continuous sail plan balance is important to enable the vane to steer the boat with minimum heel and rudder deflection.

Running:

See Diagram C on Page 9. There is less apparent wind and therefore wind pressure to the air foil on this point of sale. Since the minimum required hull speed is around 2.5 knots, you will need enough wind to achieve this for your particular vessel. To operate the wind vane, turn the counter weight to face windward (aft), via the course setting line and dial in either the tiller or the wheel drum. Use the correct air foil for your current conditions. Use the light foil in under 20 knots of apparent wind.

Reaching:

On any given day, this point of sail always provides more apparent wind than running. You may find the smaller air foil is sufficient when the larger light air foil may be needed downwind. To operate the system, again turn the counter weight windward, via the course setting line, allowing a little servo bias to compensate for the normal weather helm.

Beating to Weather:

This point of sail provides the highest apparent wind and therefore wind pressure. Most vessels will tack to weather with a well balanced sail plan requiring only minimum of help from the unit. To operate, again turn the counter weight windward, via the course setting line, allowing for a little servo bias to compensate for the normal weather helm.

A common question is::

How much wind is needed to operate the wind vane? A quick way to find out how much wind your vessel needs is to motor slowly along and hold the air foil to one extreme. When the servo starts to deflect, that's your hull speed. Relate this to the amount of wind pressure (just sailing, no engine) to achieve the same hull speed. For your vessel, this is your "starting point."

YACHT SAILING DOWNWIND - Diagram C

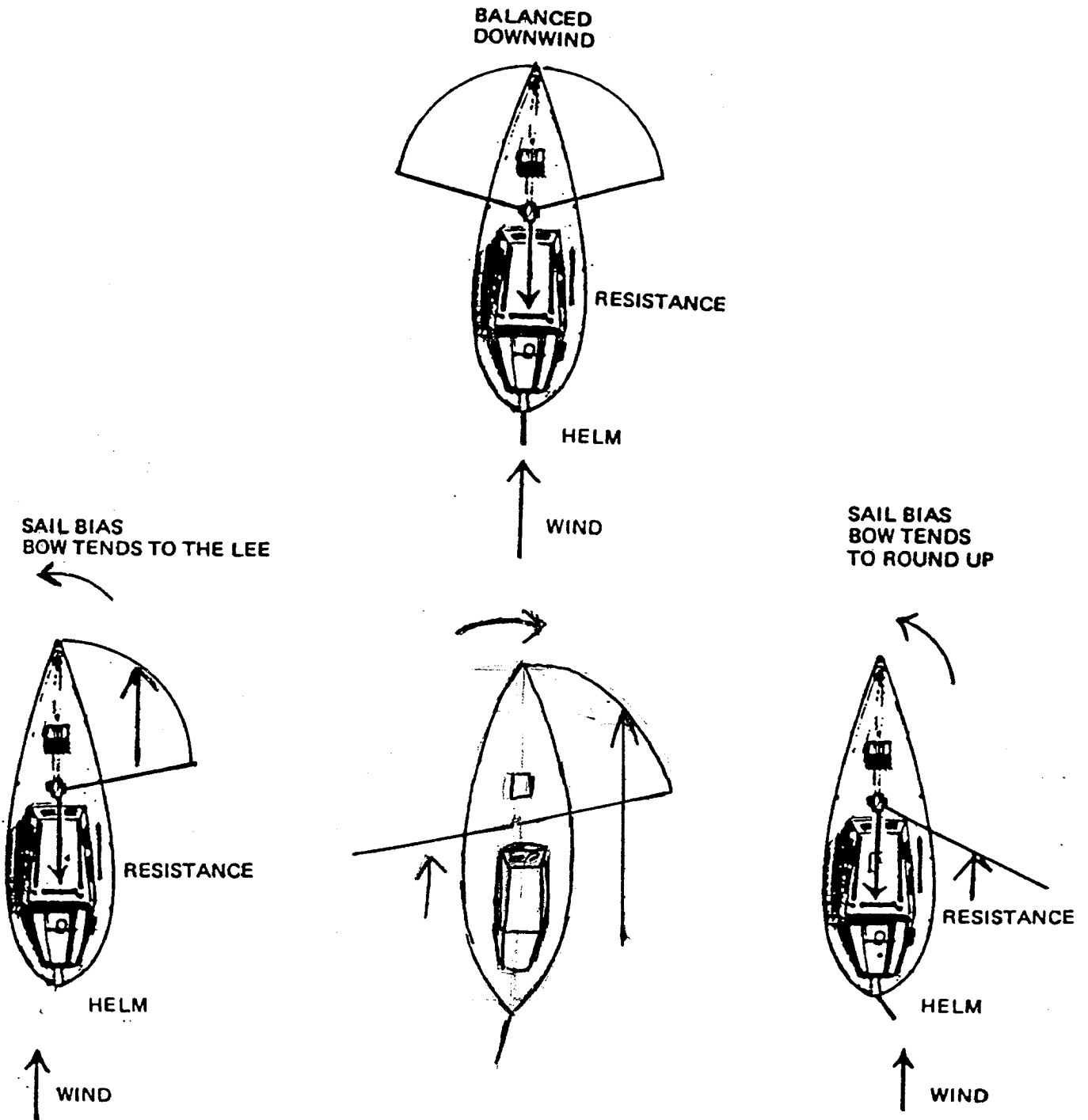

SAILING CHECK LIST

Before you set sail:

1. Are the control lines tight? When you move the wheel slightly, the wind vane servo arm should immediately move without showing any slack in the control lines.
2. Are the control lines run correctly? When the wheel is moved to starboard, the servo rudder should move to port?
3. Is the main steering system friction and wear free? Will it effect the vane's performance in light air? To check for excessive friction in the steering system, stand behind the wheel and place a finger on a spoke at the outer rim. Rotate the wheel without undue pressure or pain on the finger. If this is uncomfortable, the vane will not be as sensitive in light air.
4. Do you have the correct air foil fitted? If it's less then 20 knots true, then use the taller light air foil.
5. Is the vane bolted on correctly? See Installing the Unit on Page 13.
6. Has the thrust washer (split) at the small gear been adjusted? It should hold the small gear snugly into the large gear but without pressure.
7. Checked all the fasteners on the wind vane to make sure they are tight.
8. The vane should correctly aligned with the turret vertical and the control line transfer arm assembly horizontal.

WIND VANE ASSEMBLY INSTRUCTIONS

PLEASE READ ENTIRE INSTRUCTIONS BEFORE BEGINNING

To assemble your new Fleming global 401, 501 system if it is delivered unassembled:

1. Remove all parts from the box and check off parts supplied. Find Diagram B.
2. Lay main shaft on the ground, gear assembly at left end.
3. Slip on inboard thrust washer (A).
4. In the same movement, slip thrust washer (B), main servo casting, and turret holder on at the same time. Juggle the 3 parts to do this. The turret holder will extend out to the front side facing the main shaft as drawn (gears at left end).
5. Bolt turret holder to the shaft, tighten thrust washers A & B.
6. Slip thrust washer (C) and horizontal gear on to shaft (left end). Be careful of the two roller bearings inside the horizontal gear. Fasten on with 1/4" bolt and washers.
7. Push main servo shaft up into servo casting. Bolt on the horizontal gear (spacer under).
8. Move the horizontal gear in to connect with the vertical servo shaft gear. The teeth should fit snugly together.
9. Bolt the air foil holder casting to the top of the turret with bolt supplied. Fit counter weight if not already attached.
10. Fit push rod.
11. Slip on control line transfer casting from right end, refer to drawing. Drive screwdriver into slot to assist this. Bolt on.
12. Bolt on the horizontal support tube and end castings to the main castings. See Diagram A.
13. Fit to the vessel, see instruction manual.
14. When the vane is finally fitted check that the air foil is upright, and the servo is fore-aft, if not then adjust the gears again by removing the split thrust washer and sliding the horizontal gear out of contact with the vertical servo shaft gear. Realign the foil and servo rudder and re-install split thrust washer so that the gears fit snugly but not tight.

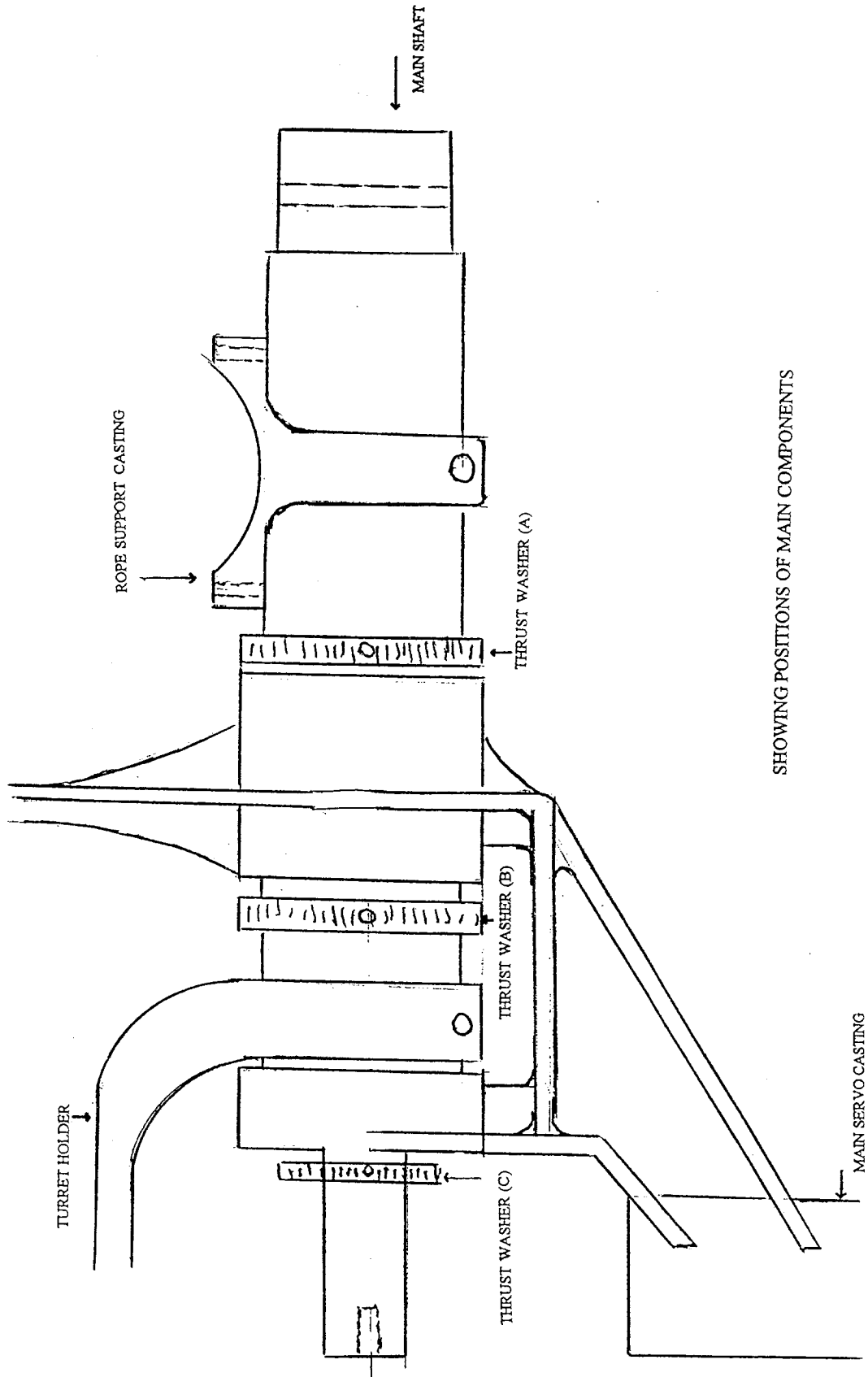

SHOWING POSITIONS OF MAIN COMPONENTS

INSTALLING THE UNIT

1. Mark the center line of the vessel or a position line if the unit is to be mounted off center. Establish the correct vertical height, so that the top of the servo rudder is at or near 4 inches out of water (static position).
3. Measure the length of the top tube (as installed on the main assembly) to ensure that it is long enough so that when the air foil is tilted and when revolved a full 360 degrees, it misses the stern pulpit, and other stern clutter.
2. Drill, seal holes and bolt the center "U" bracket to the hull into chosen position. Seal holes.
4. Drill and bolt the top mounting tube to the center shaft of the vane.
5. Offer the wind vane up to the top hull "U" bracket with the socket slipped on the mounting tube but not fastened. Slip a bolt through the socket and hull "U" bracket to support the vane. Add other supporting lines as required.
6. Step back and make sure the vane is in the final upright, vertical position, then mark and drill the inboard socket to the top mounting tube. Remove vane to do so.
7. Remount the vane and re-tie. **The wind vane horizontal support tube should be mounted with the wings on the cast, end caps pointing aft or outboard.** Attach the angle "L" brackets under the wings and attach a socket. Establish the two lower support positions on the hull. Remembering to take into account a socket on each end and the "U" bracket on the hull, measure and cut these mounting tubes. Don't drill hull yet.
8. Bolt a socket to each tube and bolt this socket to the angle "L" bracket attached to the cast, end caps of the horizontal support tube. Slip the other sockets already bolted to "U" brackets on the lower end of both tubes. Offer both tubes up to the hull. Twist until they are flat against the hull. Mark the socket hole on each tube port and starboard. Drill holes in lower end of mounting tubes.
9. With lower hole drilled, bolt the sockets to the tube and attach the "U" brackets. Offer again up to the hull to mark the final "U" bracket through hull position. Drill, seal and bolt up to the hull.
10. Take your time to position the unit before you drill holes. Stand back and ensure it looks vertical and right for you.

"Good luck and good sailing"

INSTALLATION - Diagram E

This sketch shows the unit tied in position, center bracket secure, no side support.

Bolt unit to center bracket to lower supports.
Ideal: 45 degrees down and 10 to 15 degrees out.
Carefully rope in place vertical and square to the stern.

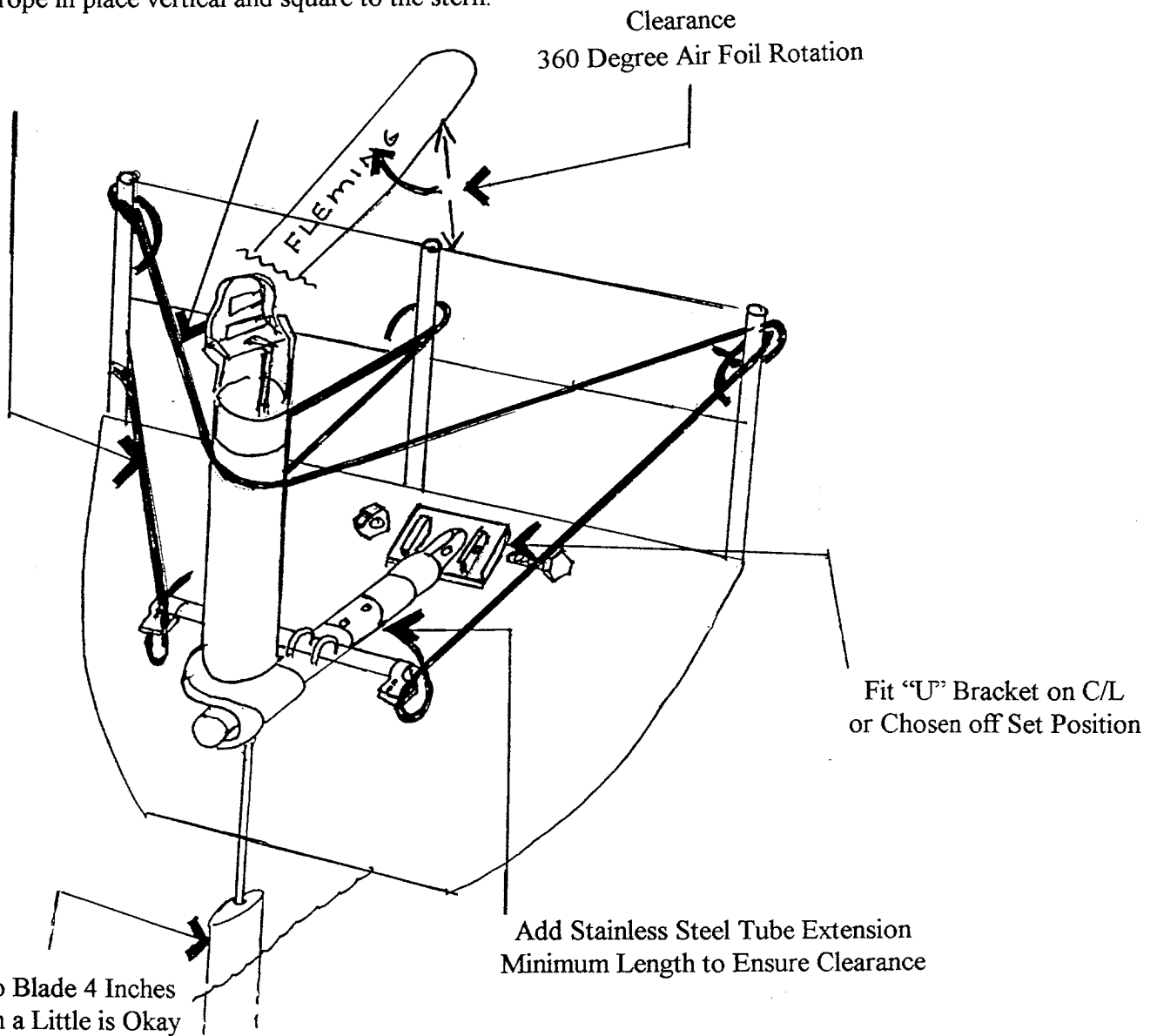

INSTALLATION OF MOUNTING TUBES - Diagram F

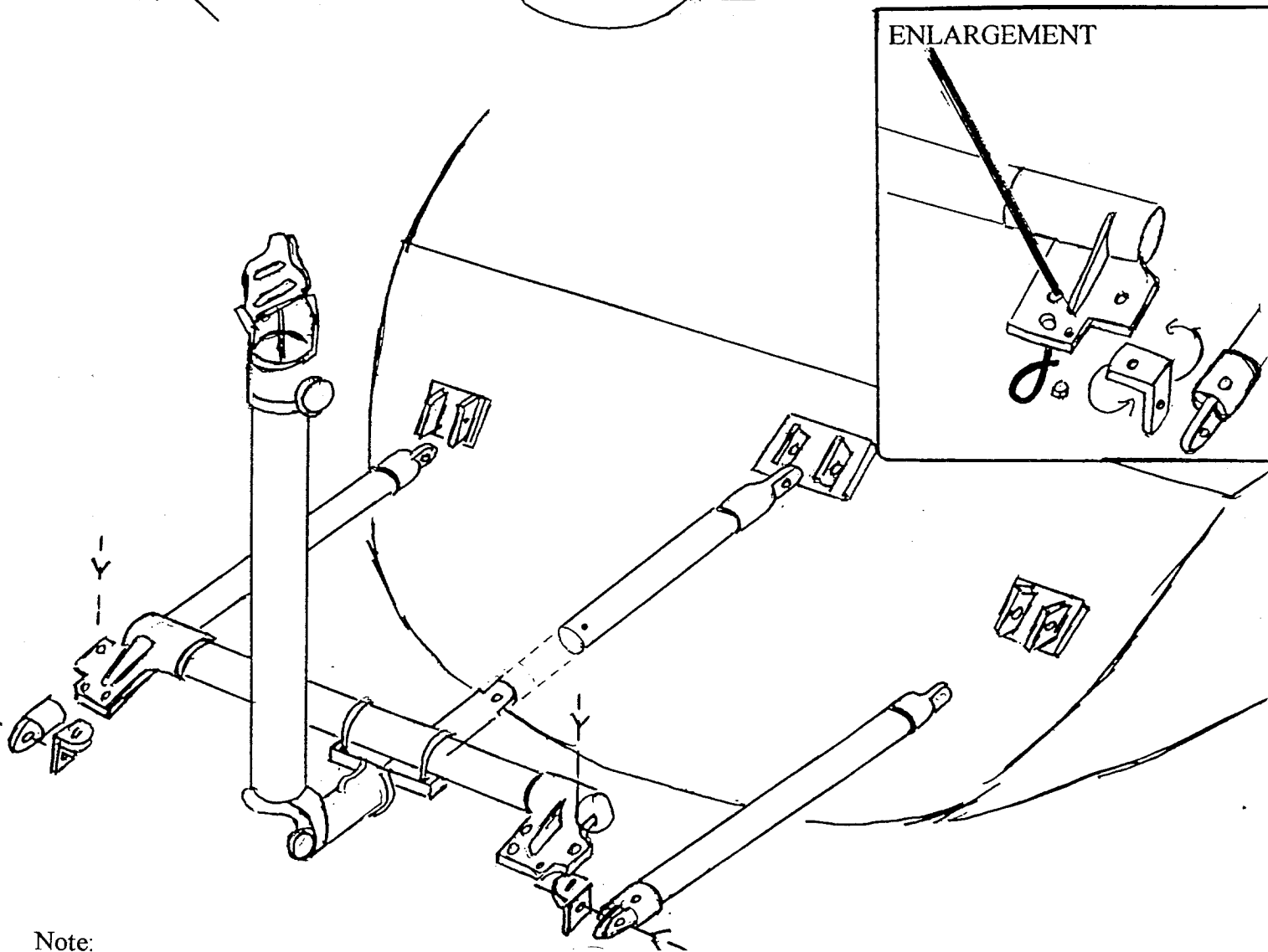
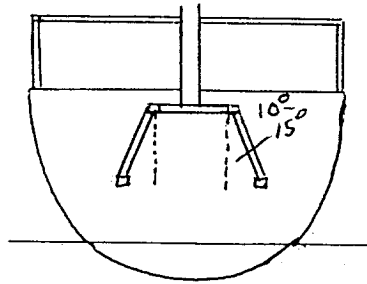
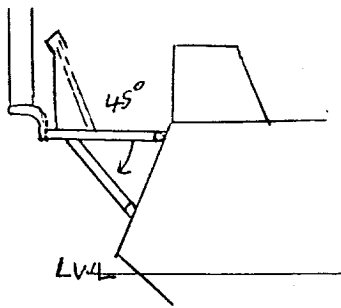

Note:

1. View from Aft.
2. Outboard support tubes down 45 degrees and 10 to 15 degrees out from Main Support Rod.

INSTALLING CONTROL LINES FROM UNIT TO WHEEL OR TILLER

Refer to Diagrams G and H.

1. Use pre-stretched line (30 feet of 3/8" included with vane). We have found over the years that this kind is best.
2. The lines should be run through the pulley sheaves fitted in the servo arm as shown and terminated at the wind vane frame by tying a knot under the through hole (aft hole to aft sheaves; forward hole to forward sheaves). Run the line over the top of the vane servo pulleys, not under and don't cross. From here, it is run to the tiller or wheel using the shortest route possible to minimize friction.
3. If using a wheel with a free wheeling clutch, approximately 5 turns of line should be wound on this clutch and then both ends led back to the wind vane through the required blocks, and then terminated on the wind vane after passing up over the servo arm pulley sheaves. Also suggested is a two line attachment arrangement. This is one line wrapped 5 turns around the clutch and with eyes on both ends. Lines from the wind vane can be attached to the eyes and slack removed.
4. When running control lines, DO NOT use swivel pulleys to change direction of both lines. Use single pulleys or blocks which can be fastened to the hull and do not move.
5. Ensure that the control line is tight, but not overly tight, to ensure vane sensitivity move the wheel slowly side to side removing any line slackness.
6. The course setting line is wrapped around the course setting knob with 1/4" line, through a pulley and spliced into a continuous loop. This leads to the cockpit or is positioned on the vessel to suit the owner's requirements and tensioned with shock cord to the pulley. Worm drive rotates either direction.
7. **It is IMPORTANT that when using a wheel drum, the lines are run around correctly, e.g. wind vane moves to port, wheel moves to starboard and vice versa.**

CONTROL LINE INSTALLATION - Diagram G

Schematic sketch of the control lines and lower support tubes: Global 401 and 501 Models

COCKPIT DISCONNECT ROPE ARRANGEMENT

Attach Line B

Stainless Steel Thimbles

Attach Line A

Vane Rope Layout - Stern View

Rod Rope Joining

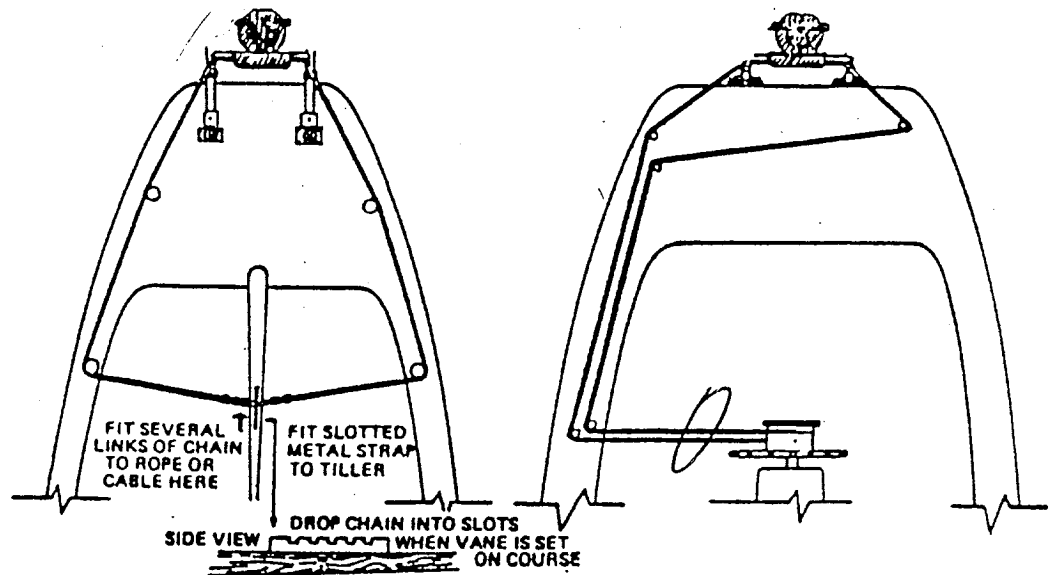

Note: 2 jam cleats work as well

MOUNTING AND CONTROL LINES - Diagram H

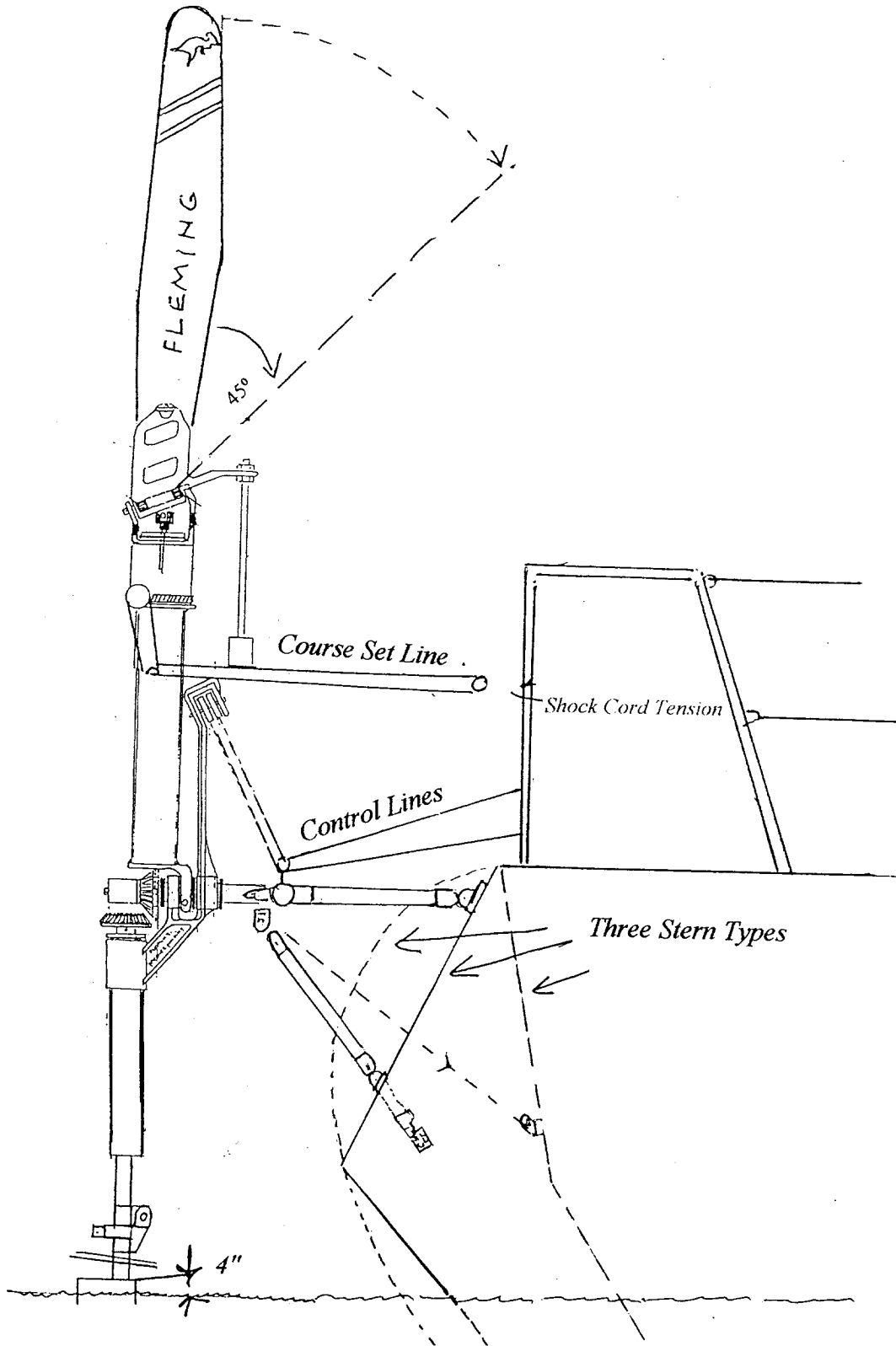

FITTING DETAIL FOR WHEEL DRUM TO STEERING WHEEL

The drum is located on the aft side (rear) of the steering wheel.

The larger flange of the wheel drum fits up against the spokes and is best located to the spokes by "U" bolts with self locking nuts. Due to the varying sizes of spokes, drums are not pre-drilled.

A wooden backing plate may have to be placed behind the drum.

A PCD groove is machined on the back of the drum to facilitate the location of the holes. Use a divider to equally step out the holes, drill 3/16" clearance hole (suit "U" bolt) on the equal spaces.

Then measure spoke width and mark out again the other set of holes. Between the holes you will have the spoke width you require.

Equally tighten the "U" bolts so the clearance between the flange and wheel spokes are the same.

WHEEL DRUM

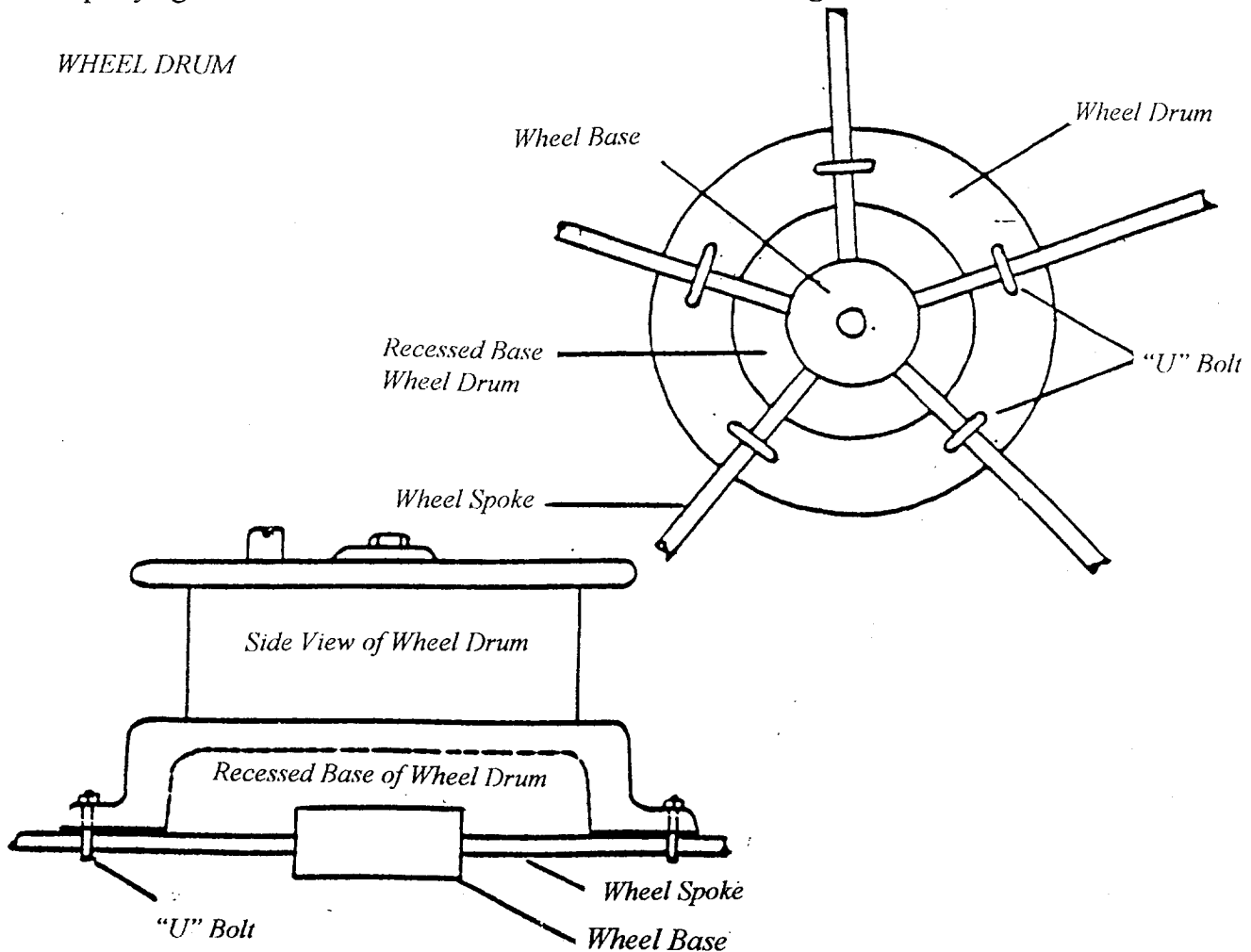

PHOTOGRAPHIC EXAMPLES OF VARIOUS INSTALLATIONS

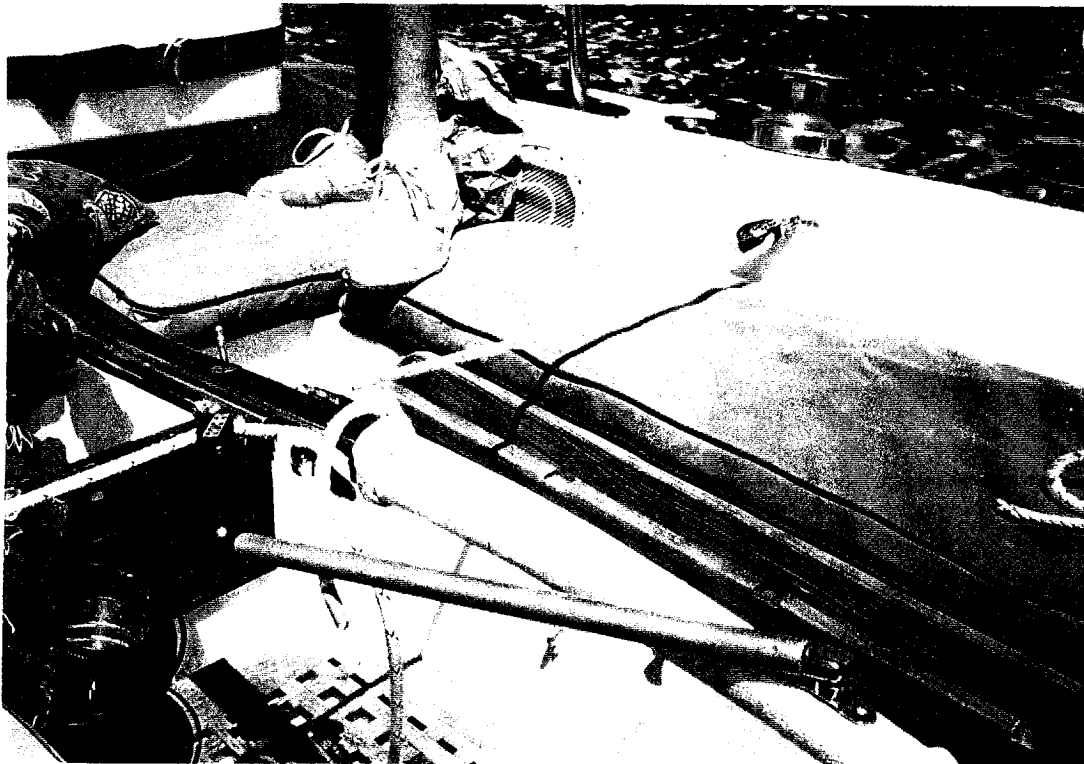
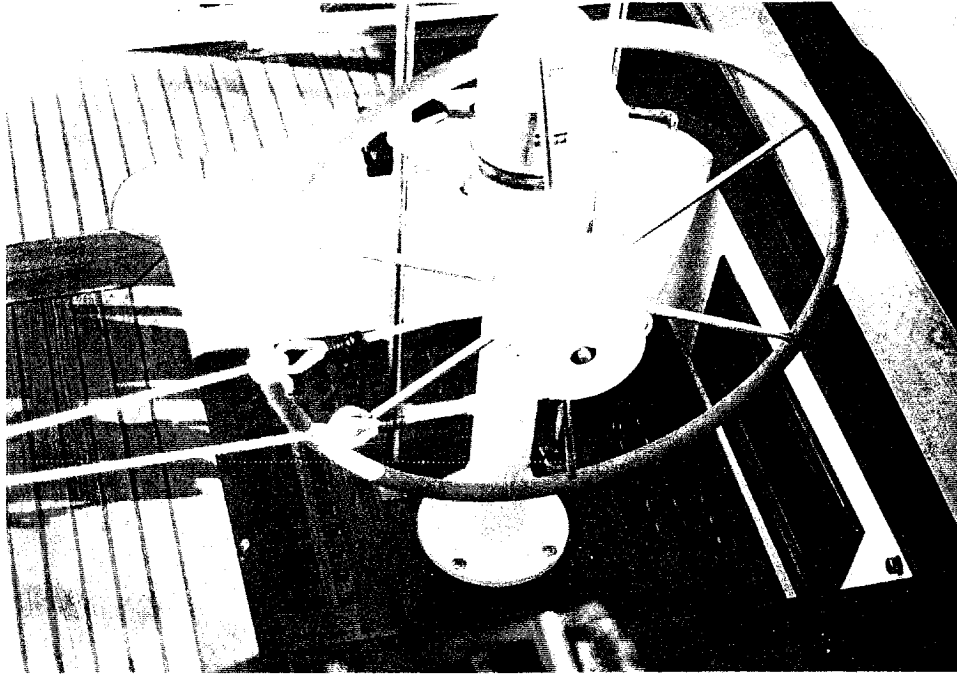

PHOTOGRAPHIC EXAMPLES OF VARIOUS INSTALLATIONS continued

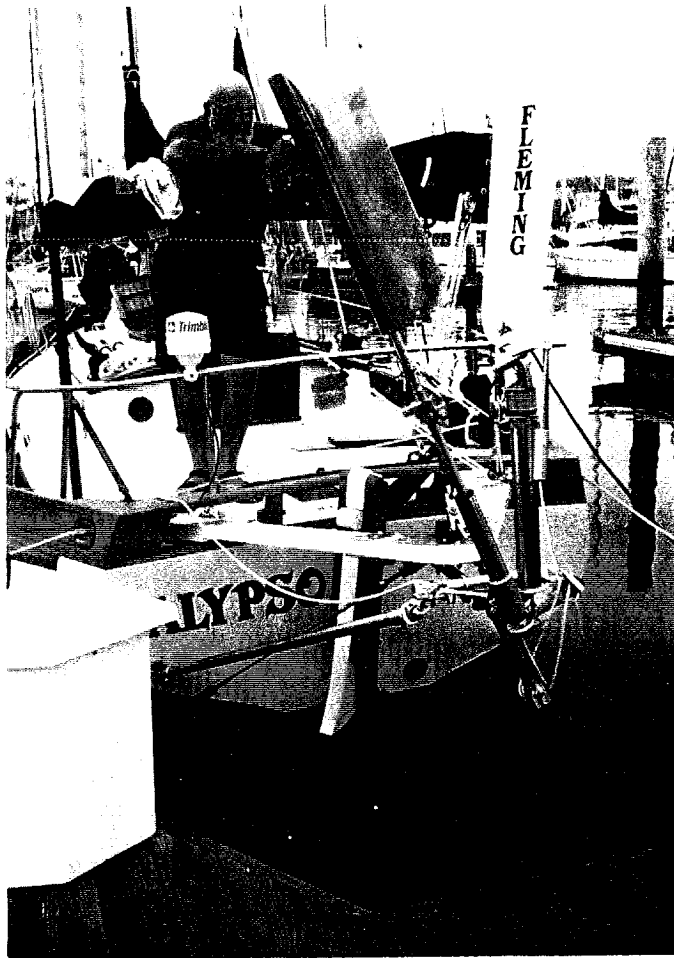

PHOTOGRAPHIC EXAMPLES OF VARIOUS INSTALLATIONS continued

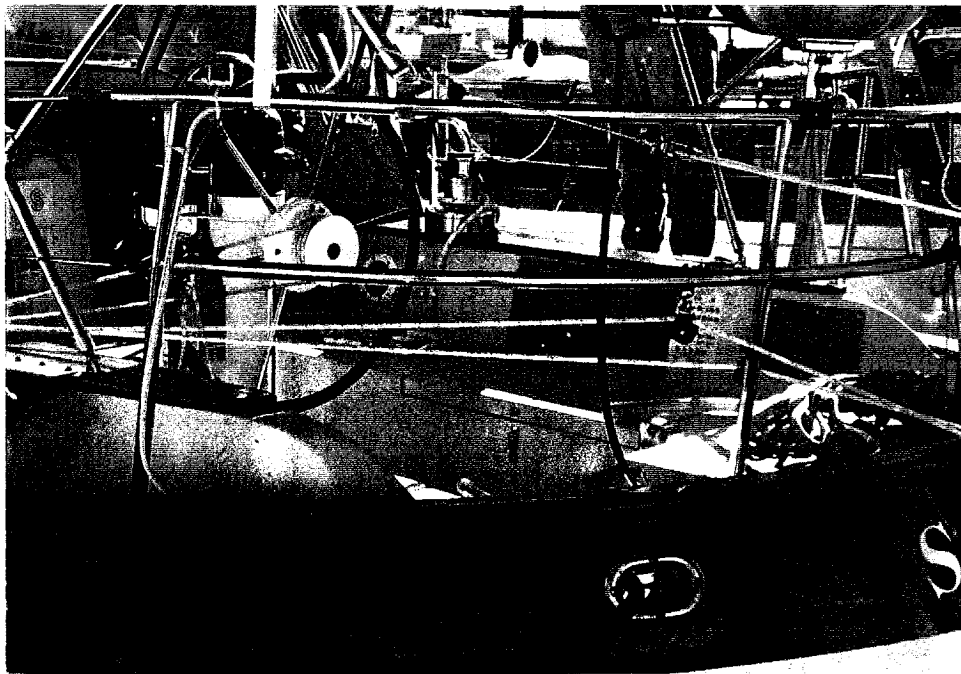
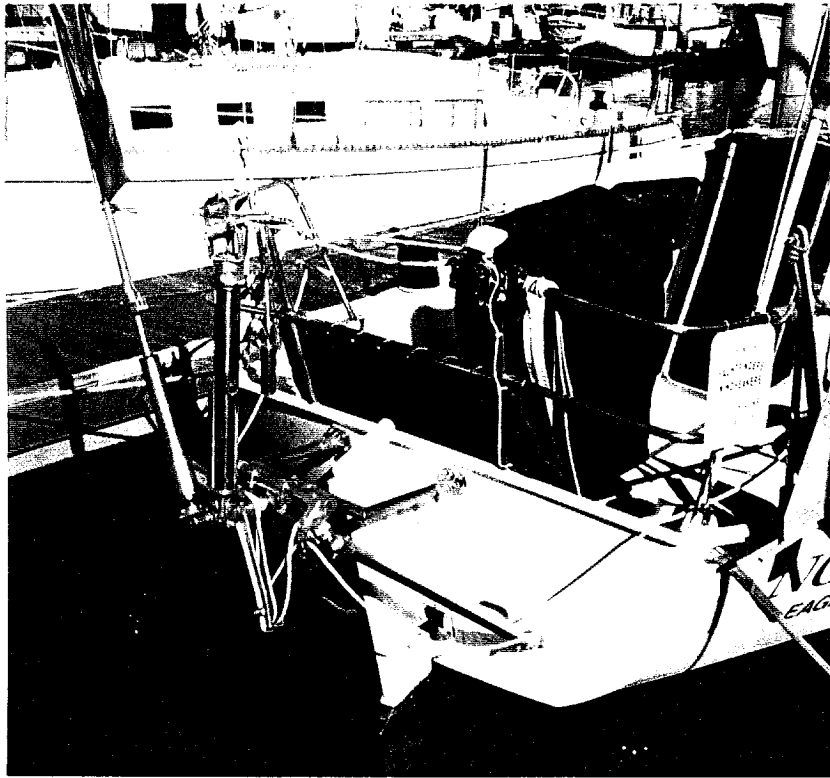

PHOTOGRAPHIC EXAMPLES OF VARIOUS INSTALLATIONS continued

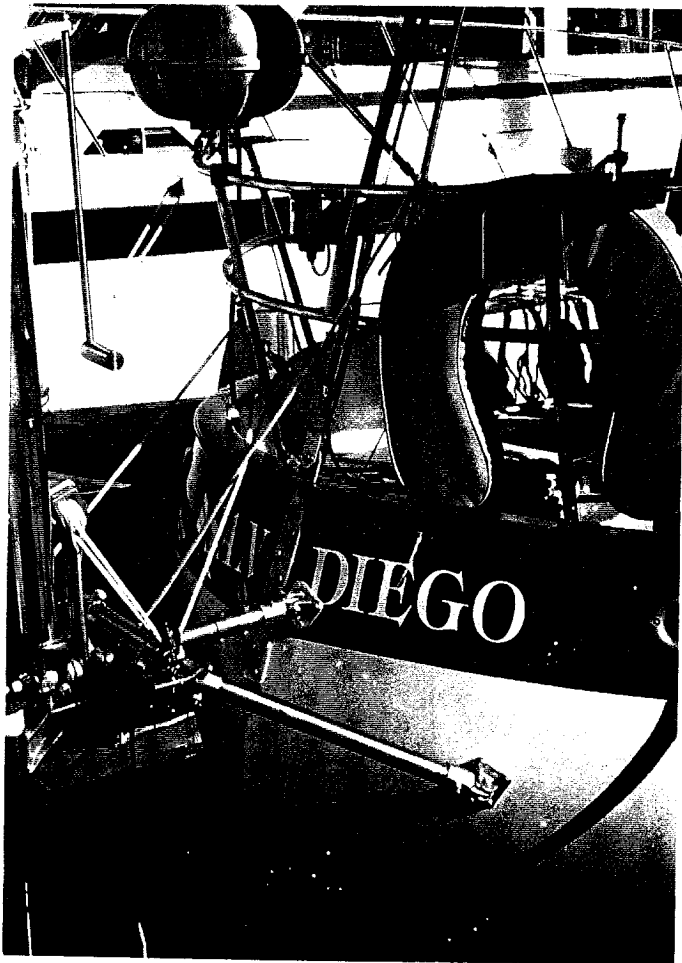

MIZZEN

Very few mizzen booms are high enough to clear the air foil. The problem is aggravated when close hauled, and the mizzen boom sheeted hard to the centerline. Under these conditions the air foil is limited in it's travel before hitting the boom. Because the apparent wind is at its strongest when closed hauled, the air foil may be pivoted aft slightly and out of the way. Slight easing of the mizzen sheets helps. When close hauled, any back winding effects from the mizzen onto the air foil are unnoticeable.

Series II - Global Self-Steering... Technical Data

	GLOBAL 401 20,000 lbs. to 40 feet		GLOBAL 501 To 60 feet Custom Models to 70 feet	
	INCHES	mm	INCHES	mm
A, Standard Foil	24.5	622	24.5	622
A Light Foil	32	812	32	812
B	9	228	9	228
C	3	76	3	76
D	16	406	16	406
E	20	50	20	50
F	13	330	13	330
G	3.5	88	3.5	88
H	16	406	20	508
I	24.5	622	27.5	698
J	11.5	292	16	406
K	2.5	63	2.5	63
L	23	584	29	736
M	36	914	43.5	1104
N	24	609	30	762
O	7	177	7	177
P	6	152	5	127
Q	1.5 (316)	381	1.5 (316)	33.1
R	9.5	241	9.5	241
S	3.5	88	3.5	88
T	13	330	13	330
U	35.5	899	35.5	899
V	16	406	16	406
W	2.5	63	2.5	63
X	2.0	50	2.0	50

NOTE: Measurements
are close approximates.

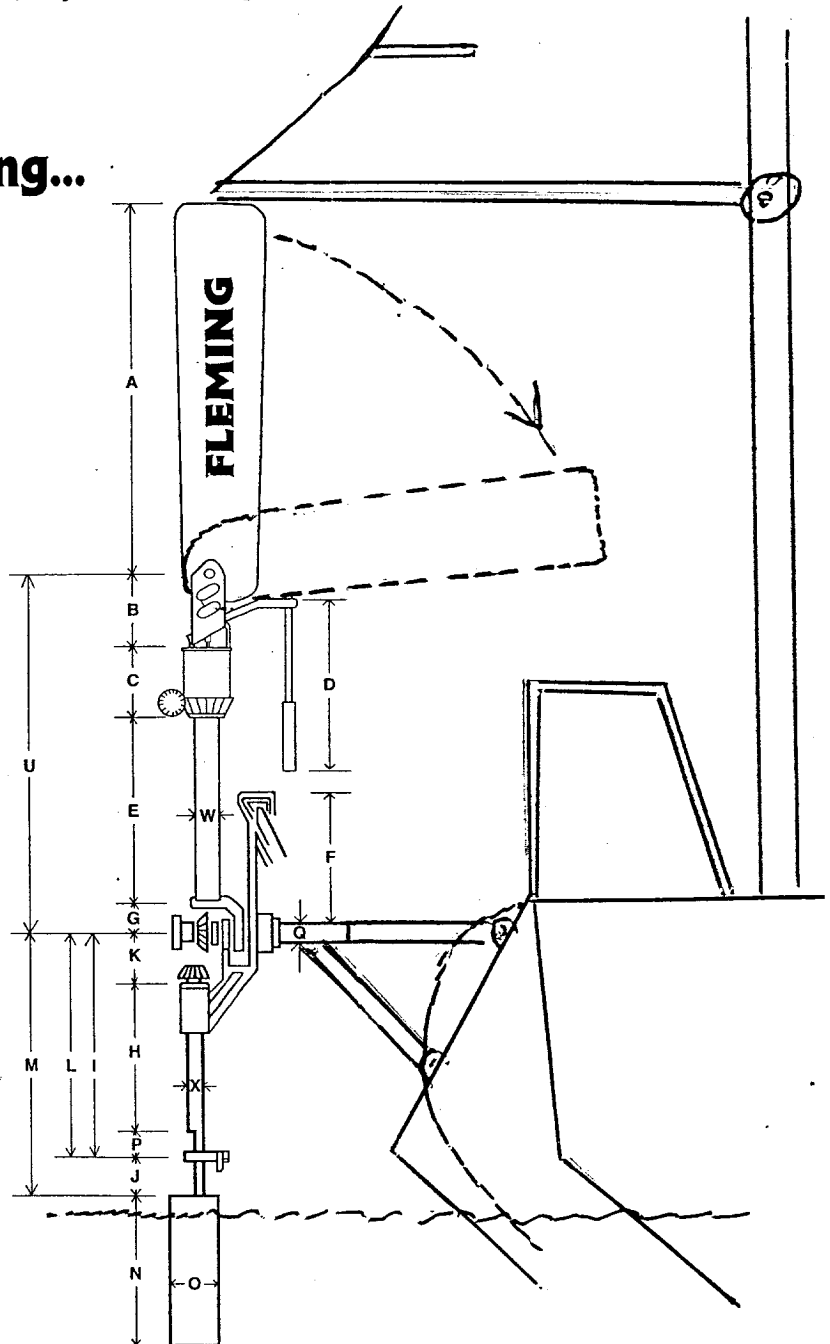

EMERGENCY RUDDER ASSEMBLY

To bring the vessel safely into port, the sails should be trimmed to assist the smaller emergency rudder. Reduce the sail area when necessary, tie the servo arm to hold the servo rudder amidships. The auto pilot can still be used.

To Assemble:

Slip the aluminum add-on section over the aft end of the servo rudder. Place the top and bottom sections over the rudder and the add-on piece. Bolt it together with the stainless steel tubes.

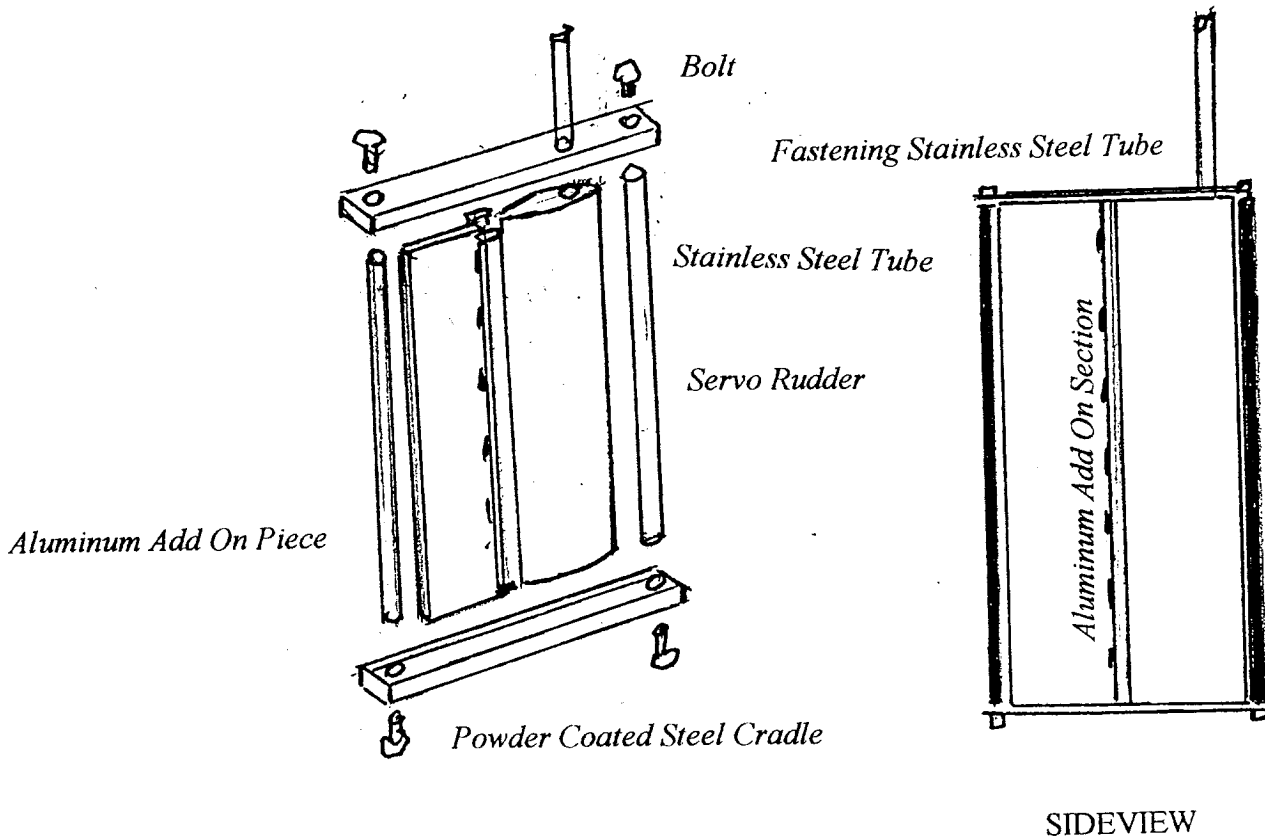

AUTOPILOT ADD ON BRACKET AND INSTALLATION

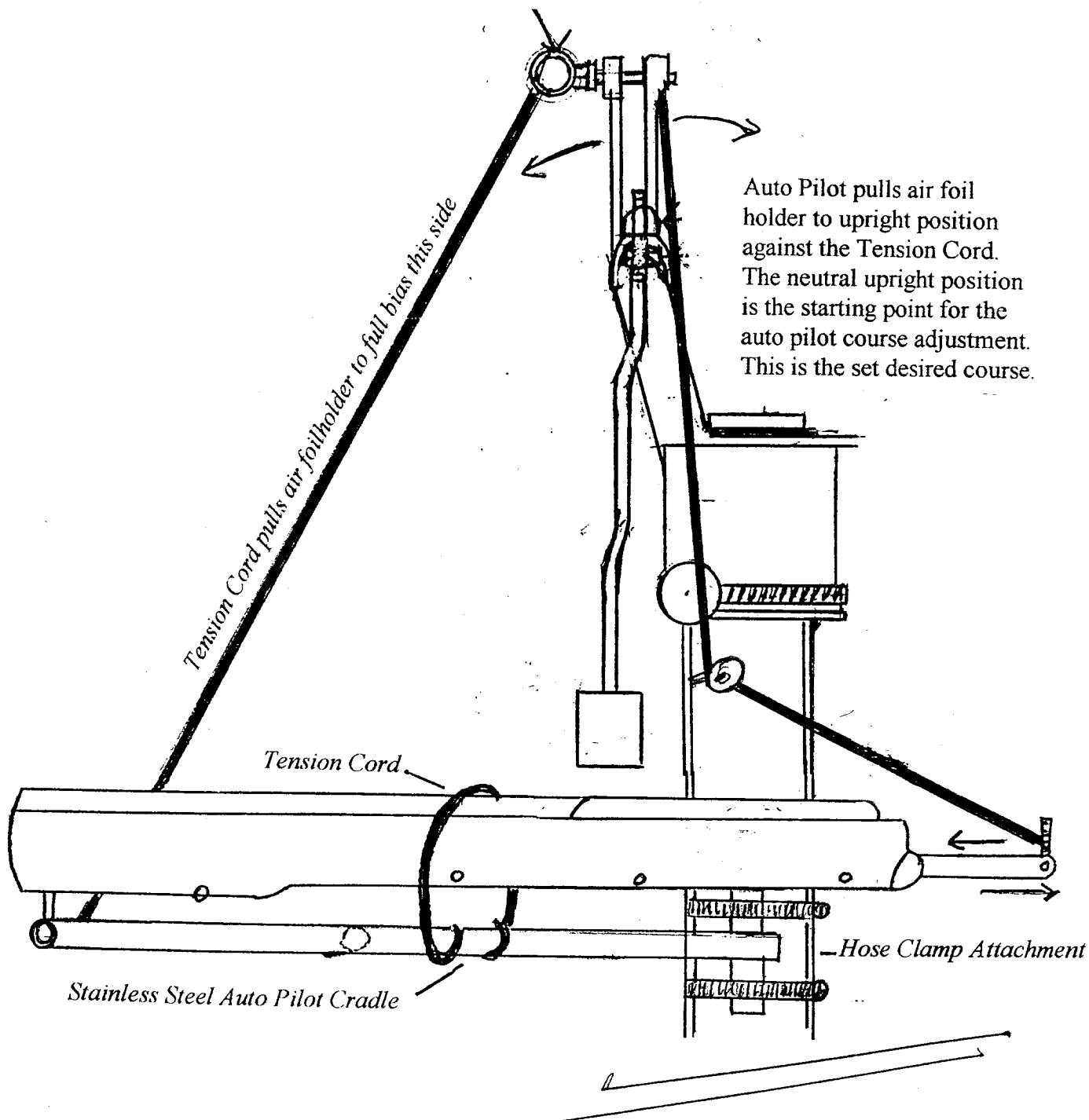

APPENDIX

CONSTRUCTION DETAILS

Type: Mechanically operated wind vane, servo pendulum self steering system.

Description: This third generation design is fitted with two bevel gears incorporating an adjustable thrust washer, revolving around the solid main support shaft at its outer end. A push rod connects the air foil to the servo rudder via the gears. The unit is sleek, stylish and lighter incorporating components cast in duplex stainless alloys which are stronger and more corrosion resistant than previous marine grades. An operating advantage on our units for over 27 years is the main servo arm design. Its built-in mechanical advantage reduces its size while maintaining an excellent line pulling length. The servo swings around the main servo shaft unrestricted, eliminating the need to any athwart ship's overload protection. Aft protection is via a replaceable shear pin.

CONSTRUCTION MATERIALS

- Castings:** The castings are produced in the investment or lost wax method in 2205 duplex alloy stainless steel.
- Shafting:** Either 316 L or 2205 duplex type, the diameter varies with model.
- Fasteners:** 316 L (cir clips 304)
- Tubing:** Wind vane tubing is 316 L
- Main Servo Tube:** Either tube or pipe 16, 12, 10 gauge depending on the model.
- Bearings:** Delrin sleeve or delrin module, sealed with stainless steel rollers, lubricated with Teflon. Maintenance free, however, we recommend they be serviced yearly.
- Air Foil:** Aluminum or birch marine grade plywood, 4 mm thick.
- Servo Rudder:** 316 L, 18 gauge sheet fitted over a solid rod and tube. The servo rudder is a semi balanced air foil section with negative displacement.

PARTS LIST:
Global 401 and 501 Models

1. Air Foil
2. Air Foil Holder
3. 3/8" s/s Nylock Nut
4. 3/8" Nut
5. Counter Weight
6. 3/8" s/s Nylock Nut
7. Roller Bearings (2) Air Foil Holder
8. Push Rod Top U Bracket
9. Push Rod Top Adjust Assembly
10. Push Rod 3/8" s/s Tube
11. Air Foil Top Support Assembly
12. Air Foil Holder Lock Bolt
13. 3/8" s/s Nylock Nut
14. 3/8" Nut
15. Retaining Ring
16. Worm Drive
17. Delrin Bearing
18. Delrin Bearing
19. Course Adjust Pulley
20. Roll Pin
21. 3/8" s/s Nylock Nut
22. 3/8" Bolt
23. Delrin Pulley Rollers (2)
24. Main Servo Arm Casting
25. U Bolts (2)
26. Bolt plus 3/8" s/s Nylock Nut
27. Line Transfer Casting
28. 3/8" s/s Nylock Nut
29. Thrust Washer Main Shaft A
30. Delrin Sleeve Bearing Main Shaft Inboard Side
31. Thrust washer Main Shaft A
32. Delrin Sleeve Bearing Main Shaft Outboard Side
33. Thrust Washer Main Shaft C
34. Spring Washer
35. Flat Washer Gear Cover
36. Roller Bearing
37. Roller Bearing
38. Main Vertical Cast Gear
39. Delrin (ball) Thrust Bearing
40. Roller Bearing (upper)
41. Main Servo Tube
42. Roller Bearing (lower)
43. Servo Arm Shaft
44. 1/2" Nylock Nut
45. 1/2" Bolt (break away)
46. Upper Casting (sheer pin swing assembly)
47. 1/4" Nylock Nut (sheer pin)
48. Sheer Pin 1/4" machine screw
49. Servo Rudder
50. Main Horizontal Cast s/s Gear
51. Horizontal Gear 5/16" Bolt & Nylock Nut
52. 3/8" Bolt Air Foil Holder Swivel
53. Delrin Space Washer
54. Delrin Spacer (Air Foil Holder)
55. Lock Grub Screw (Servo Tube Low End)
56. Course Set Casting
57. Lower Casting (sheer pin swing assembly)
58. Main Shaft (solid rod)

PART LOCATIONS

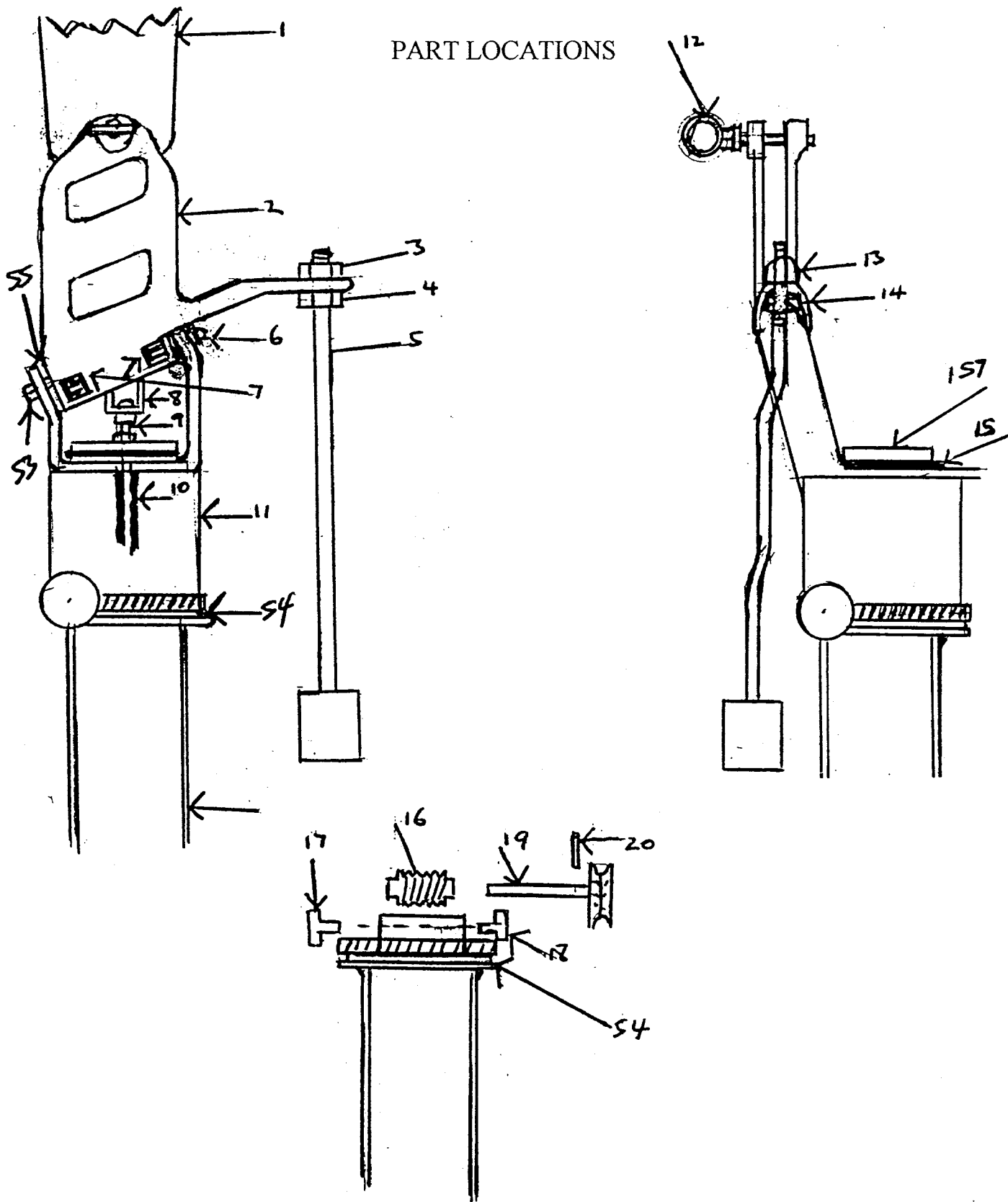

PART LOCATIONS - continued

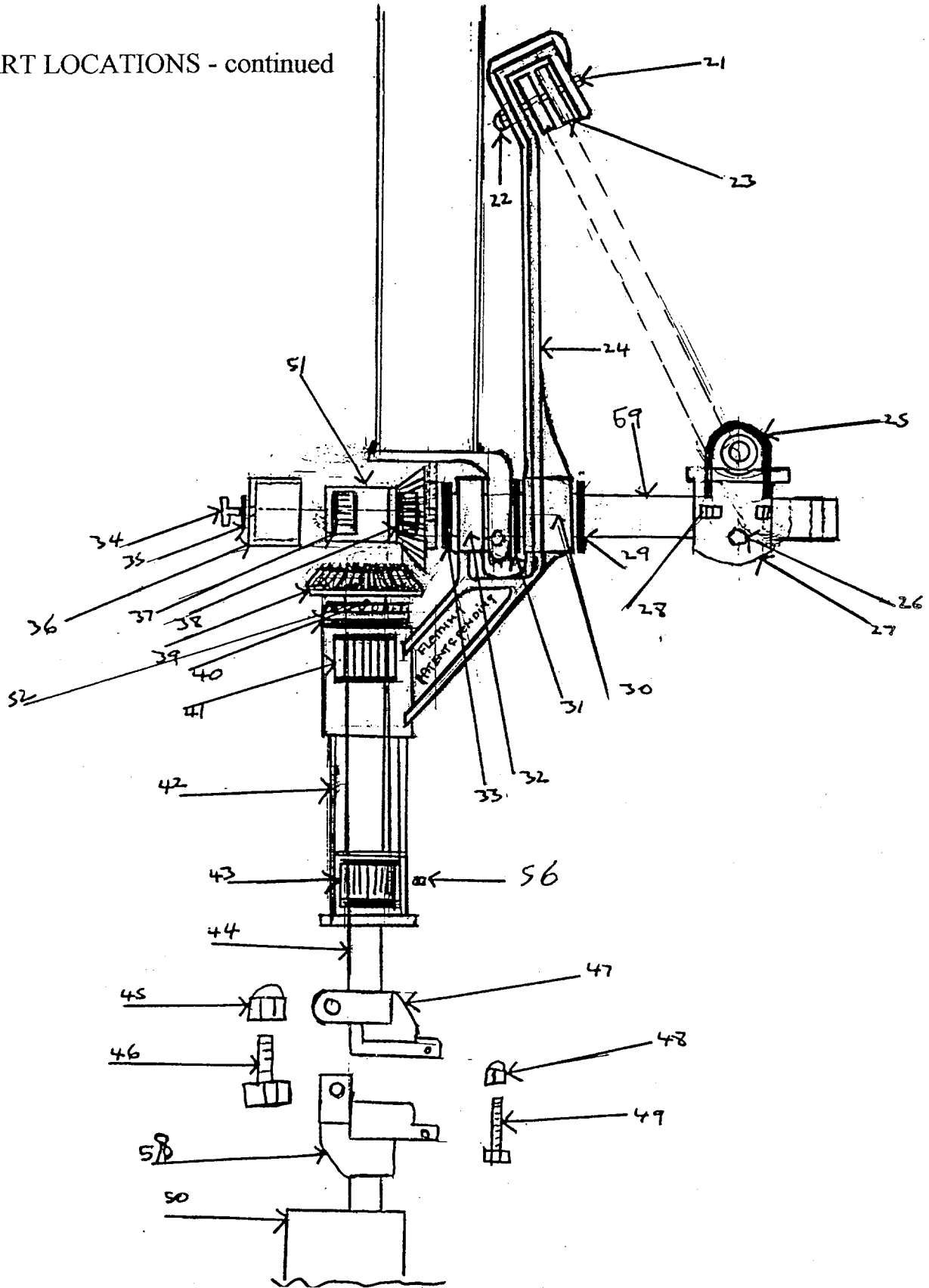

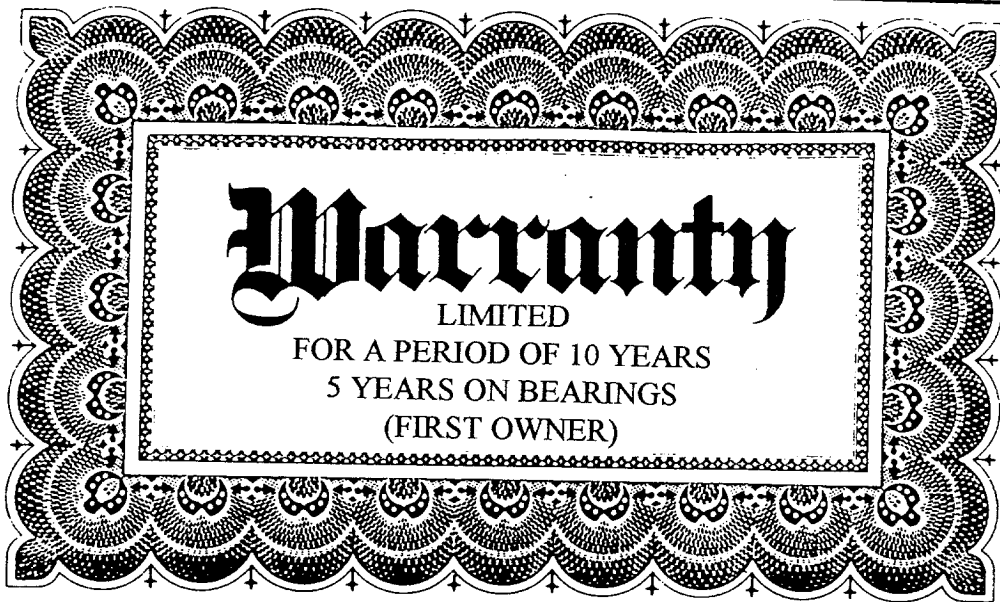

Fleming Wind Vane model: _____ Serial Number: _____

Owner's Name and Address: _____

City: _____ State: _____ Country: _____ Zip: _____

Vessel Name: _____ Document of CF #: _____

Signature: _____ Date: _____

Fleming Self Steering Systems International warrants each Fleming Wind Vane to be free from defects in material and workmanship for a period of 10 years (5 years on the bearings) for the first owner. The warranty shall become effective upon delivery and shall identify the Product so registered by the serial number. This warranty shall remain in effect for a period of 10 years from the date of delivery.

Since this warranty applies to defects in material and workmanship, it does not apply to normal worn parts, or to damage caused by neglect, lack of maintenance, accident, abnormal operation or improper installation or service.

Our obligation under this Warranty shall be limited to repairing a defective part or, at our option, replacing such part or parts as shall be necessary to remedy any malfunction resulting from defects in material or workmanship as covered by this Warranty. We reserve the right to improve the design of any Product without assuming any obligation to modify any Product previously manufactured. All incidental and/or consequential damages are excluded from this Warranty. Implied warranties are limited to the life of this Warranty.