

CHAPTER 3

FUEL INJECTION EQUIPMENT

<u>1</u>	<u>Fuel Supply System</u>	<u>3-1</u>
<u>2</u>	<u>Disassembly Reassembly and Inspection of Governor</u>	<u>3-9</u>
<u>3</u>	<u>Disassembly, Reassembly and Inspection of Fuel Injection Pump</u>	<u>3-18</u>
<u>4</u>	<u>Adjustment of Fuel Injection Pump and Governor</u>	<u>3-28</u>
<u>5</u>	<u>Automatic Advancing Timer</u>	<u>3-34</u>
<u>6</u>	<u>Fuel Feed Pump</u>	<u>3-36</u>
<u>7</u>	<u>Fuel Injection Nozzle</u>	<u>3-38</u>
<u>8</u>	<u>Troubleshooting</u>	<u>3-42</u>
<u>9</u>	<u>Fuel Injection pump Service Data</u>	<u>3-44</u>
<u>10</u>	<u>Tools</u>	<u>3-45</u>
<u>11</u>	<u>Fuel Filter</u>	<u>3-47</u>
<u>12</u>	<u>Fuel Tank (Optional)</u>	<u>3-48</u>
<u>13</u>	<u>Design Change of Fuel Piping Line</u>	<u>3-49</u>

1. Fuel Supply System

The Yanmar fuel injection pump is Bosch cluster type, the cam shaft of which is driven by the engine gears through the timing gear. The feed pump, driven by the cam shaft, pumps fuel oil from the fuel tank to the fuel filter at a pressure of 0.3kg/cm². The filtered fuel is supplied to the reservoir in the pump housing, the plunger increases the pressure, and the fuel goes through the injection pipe to be injected into each cylinder by the fuel injection nozzles.

IMPORTANT:

Automatic timer assembly, fuel injection nozzle assembly and injection pipe differ among engine models. When incorrect parts are installed, engine performance will drop.

Be sure to check the applicable engine model identification marks (I. D. Marks) provided on each part to insure use of the correct part.

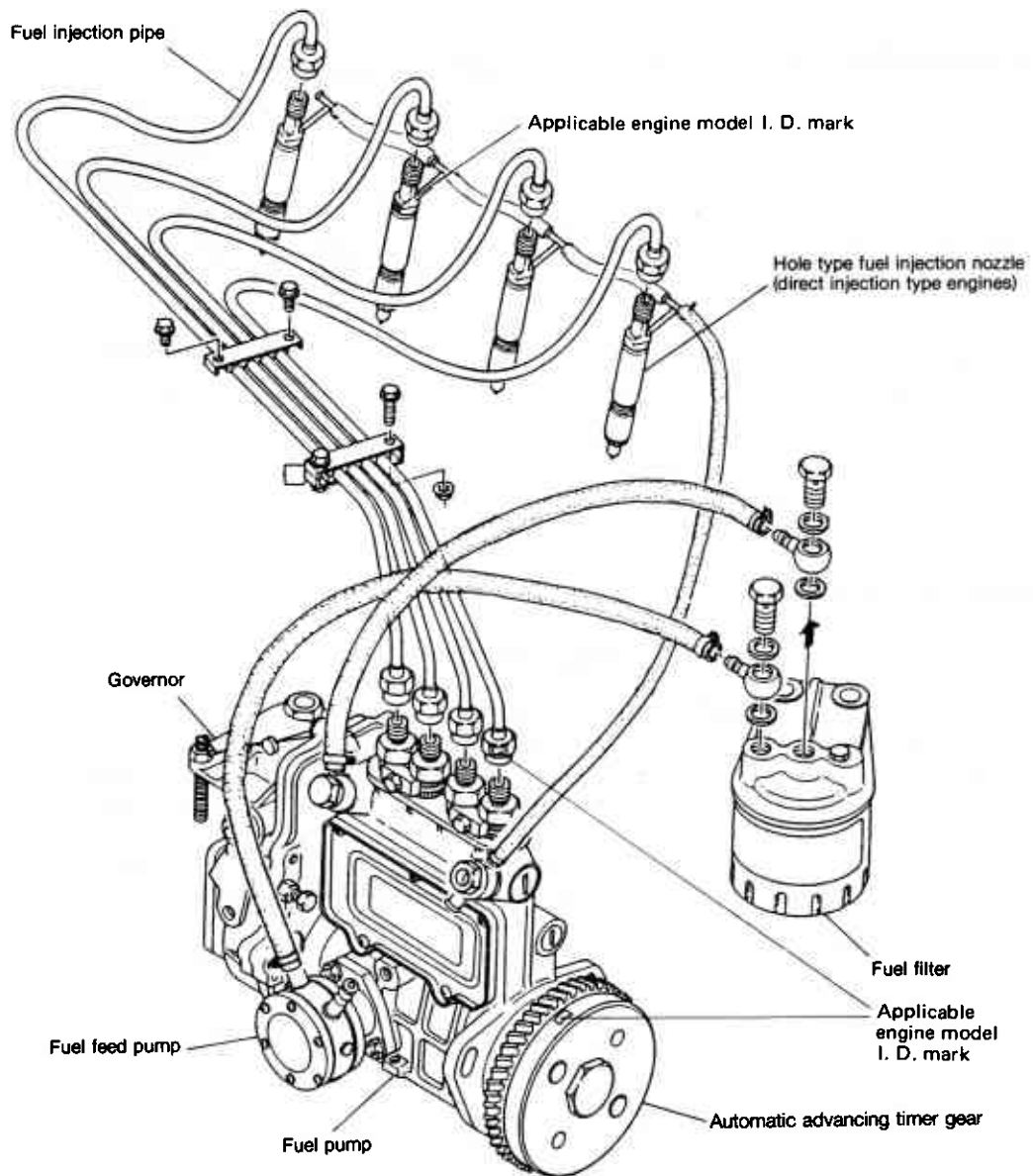

I. D. Marks for Automatic Timer Assembly

Automatic Timer Ass'y (Automatic Advancing Timer)	Old type	I. D. Mark	Applicable Engine Model & E/#	
		JH-A0	4JHE	E/# 00101 ~ 00574
		JH-A1	4JHE	E/# 01000 and before
		JH-B0	4JH-TE	E/# 11000 and before
		JH-C0	4JH-HTE	E/# 21000 and before
	New type	TN-A0	4JHE	E/# 01001 and after
		JH-C0	4JH-TE	E/# 11001 and after
			4JH-HTE	E/# 21001 and after
			4JH-DTE	E/# 30101 and after

I. D. Marks for Fuel Injection Nozzle Assembly and Fuel Injection Pipe

Fuel injection nozzle ass'y	Old type	I. D. Mark	Applicable Engine Model & E/#		Nozzle I. D. Mark
		A	4JHE	E/# 00101 ~ 00574	
		E	4JHE	E/# 01000 and before	155P244J1
		B	4JH-TE	E/# 11000 and before	150P284J0
		D	4JH-HTE	E/# 21000 and before	145P265J1
	New type	F	4JHE	E/# 01001 and after	155P244J2
		G	4JH-TE	E/# 11001 and after	140P255J2
			4JH-HTE	E/# 21001 and after	
			4JH-DTE	E/# 30101 and after	

I. D. Marks for Fuel Injection Pipe

Fuel Injection Pipe (Pump to Nozzle)	Old type	I. D. Mark	Applicable Engine Model & E/#		Pipe Inner Dia
		None	4JHE	E/# 01000 and before	
			4JH-TE	E/# 11000 and before	
		None	4JH-HTE	E/# 21000 and before	φ2.0
	New type	18	4JHE	E/# 01001 and after	φ1.8
4JH-TE			E/# 11001 and after		
20		4JH-HTE	E/# 21001 and after	φ2.0	
		4JH-DTE	E/# 30101 and after		

1-1 Fuel injection pump construction

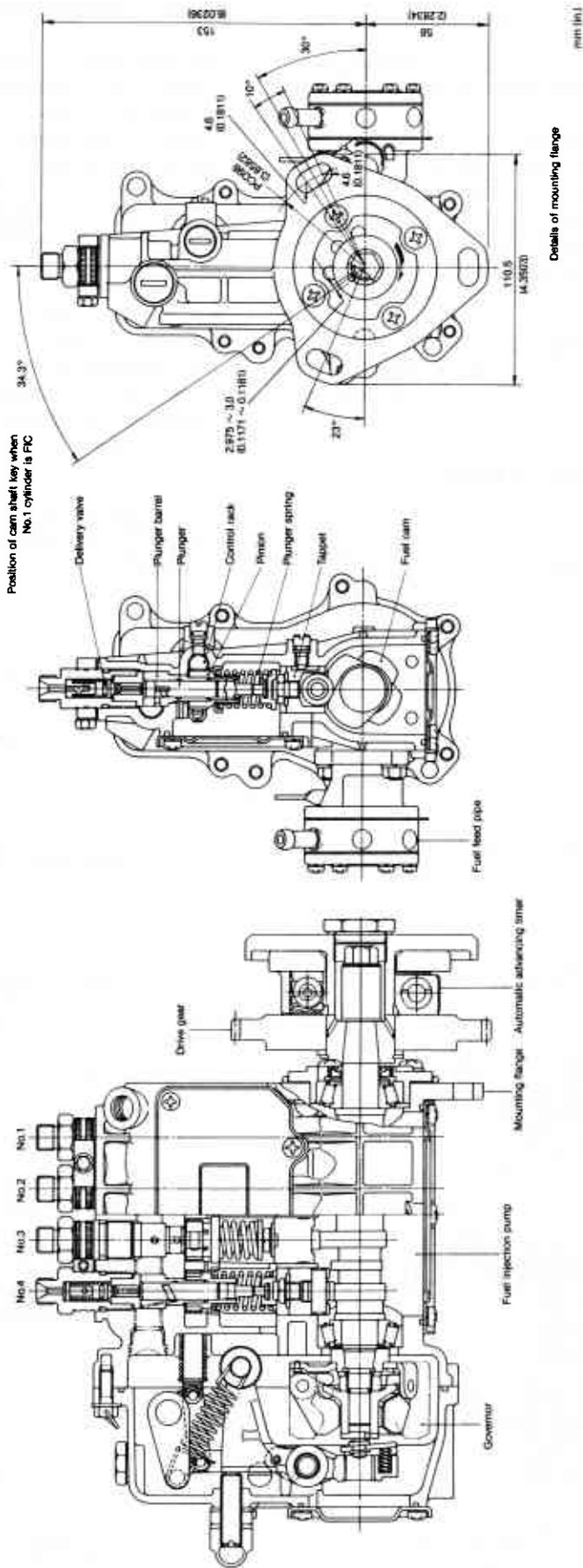

The Yanmar Model YPES Bosch type fuel injection pump is an in-line cluster type pump with a governor and timer incorporated.

A cam shaft is built into the fuel injection pump, which has a drive cam for the fuel supply pump and a tappet drive cam for the plunger. A timing gear and drive gear are mounted on the drive side of the cam shaft, and a governor weight on the opposite side.

As the plunger rises, the fuel oil opens the delivery valve and goes through the high pressure pipe to the fuel injection nozzles.

When the control rack connected to the governor lever moves, the pinion turns the plunger. This changes the fuel discharge and intake positions and in turn controls the amount of fuel injected.

1-2 Fuel injection pump specifications

Type		YPES-CL
No of cylinders		4
Plunger dia.	mm (in.)	8 (0.3149)
Cam lift	mm (in.)	7 (0.2755)
Max. fuel injection volume	mm ³ /st	65 (0.0039)
Max. fuel injection press.	kg/cm ² (lb/in. ²)	450 (6399)
Max. cam shaft	rpm	2200
Direction of revolution		right (looking from drive side)

1-3 Functioning of fuel injection pump

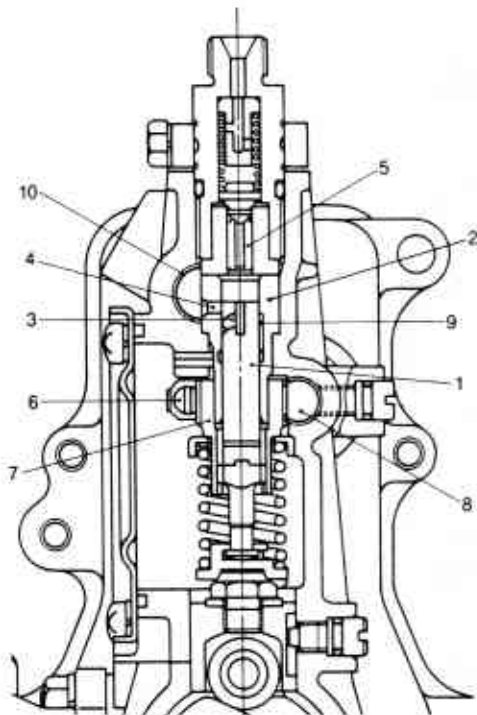

- 1. Plunger
- 2. Plunger barrel
- 3. Lead groove
- 4. Intake port
- 5. Delivery valve
- 6. Control sleeve
- 7. Control pinion
- 8. Control rack
- 9. Fuel leak return groove
- 10. Protector

The fuel injection pump supplies pressurized fuel to the injection nozzles through the action of the plunger. The plunger reciprocates in the plunger barrel through a fixed stroke and is lapped for a precise fit. A lead groove is helically cut in the plunger, and this leads to a connecting groove which goes to the top of the plunger.

There is a port in the plunger barrel which serves as both an intake and discharge port. The fuel comes through this port into the plunger chamber, is pressurized by the plunger, opens the delivery valve, flows to the fuel injection nozzle through the fuel injection pipe and is injected into the combustion chamber. Fuel injection terminates after the pressurized fuel has been discharged. This happens when the lead groove lines up with the discharge groove as the plunger rises and the pressure in the fuel injection pipe drops.

The control sleeve groove is fitted to the plunger flange. The control sleeve is secured to the control pinion and the pinion teeth and rack gear teeth are engaged.

The plunger is controlled by the rack, enabling continuous changing of the volume of fuel injected from zero to maximum. A fuel leak return hole is provided in the plunger barrel. This returns fuel leaking from the gap between the plunger and the barrel to the fuel lines. This prevents dilution of the lubricant in the cam chamber.

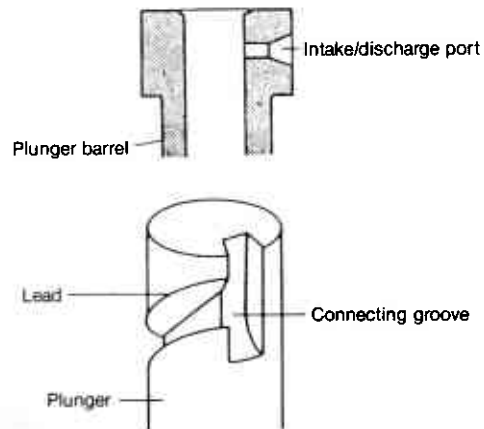

1-4 Injection volume control

(1) Full injection volume position

When the rack is set at the maximum setting, fuel injection starts earlier. It occurs when the widest part of the lead groove on the upper part of plunger lines up with the intake port in the barrel. At this time, the nar-

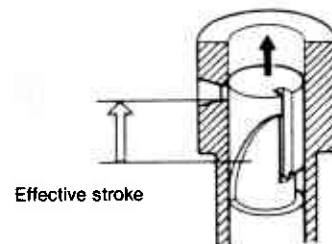

lowest part of the lower lead groove lines up with the discharge port, prolonging the length of injection and increasing the volume of fuel injected.

This setting is normally used for starting and max. output operation.

(2) Half injection volume position

When the rack is returned towards zero from the maximum setting, discharge starts later and ends earlier, decreasing the volume of fuel injected.

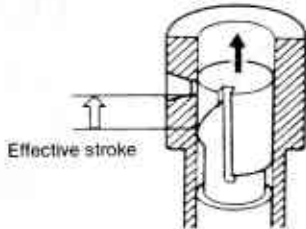

(3) No fuel injection

When the rack is set near zero, the intake/discharge port in the barrel is always open, so no fuel is pressurized (even though the plunger continues to reciprocate).

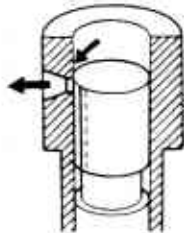

The delivery valve at the top of the plunger prevents fuel in the fuel injection pipe from flowing back to the

plunger and sucks up fuel from the nozzle valve to prevent after drip.

When the plunger lead lines up with the discharge port of the plunger barrel, the injection pressure drops, and the delivery valve is brought down by the delivery valve spring.

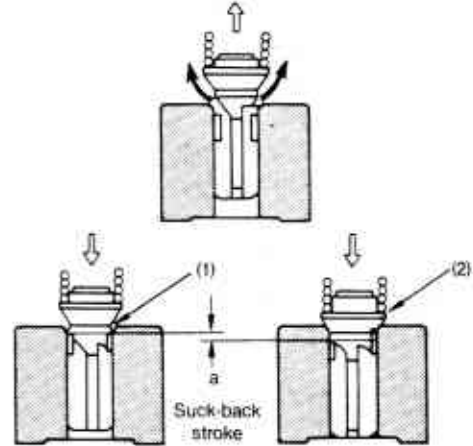

At this time, the suck-back collar (1) blocks off the fuel injection pipe and the delivery chamber, and the valve continues to descend until the seat (2) comes in contact with the barrel. The fuel oil pressure in the fuel injection pipe decreases proportionately with the lowering of the valve (due to increased volume).

This accelerates closing of the nozzle valve, and sucks up fuel from the nozzle to prevent it from dripping.

This increases nozzle life and improves combustion efficiency.

1-5 Governor construction

Usage conditions of diesel engines are extremely varied, with a wide range of loads and rpms. The governor plays an important role in the operation of the engine by quickly adjusting the position of the control rack to control the

amount of fuel injected according to changes in rpm. It also automatically controls the engine to prevent engine rpm from exceeding the maximum, and keeps the engine from stopping.

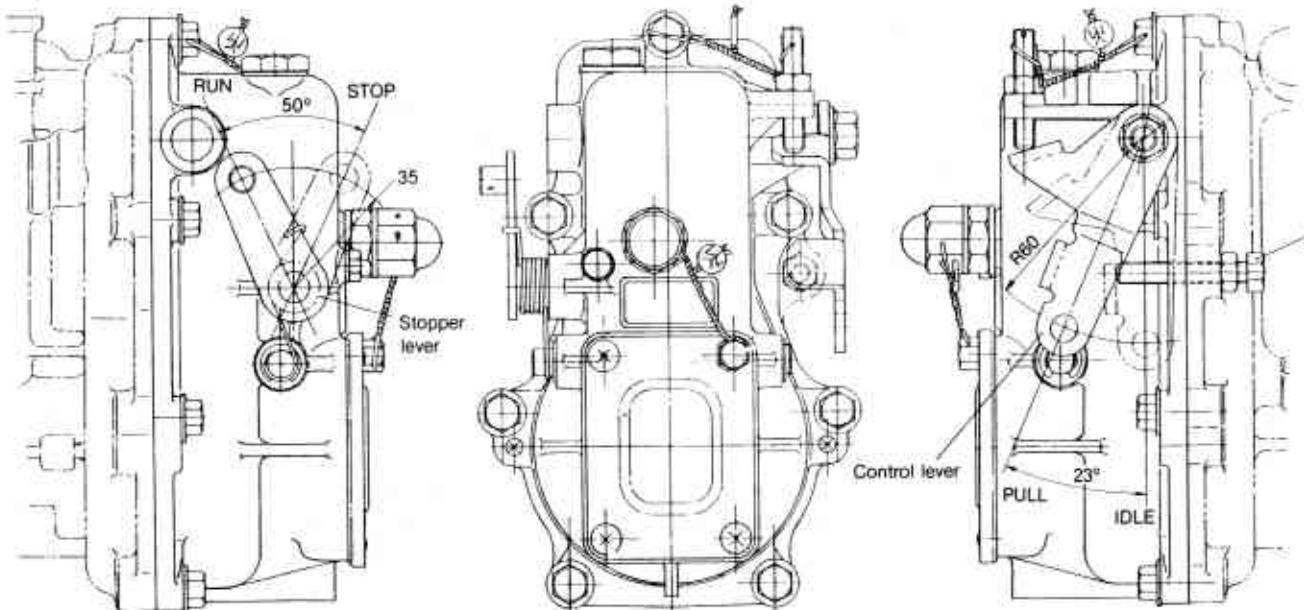

(1) A-type governor (without angleich spring)

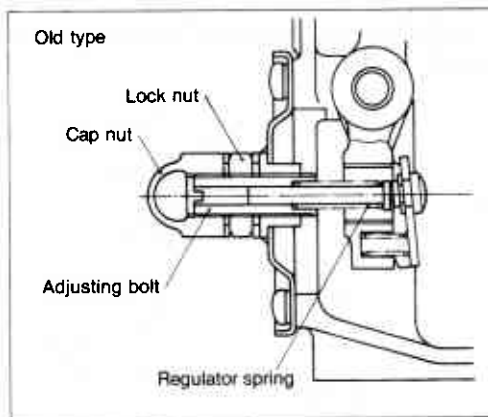
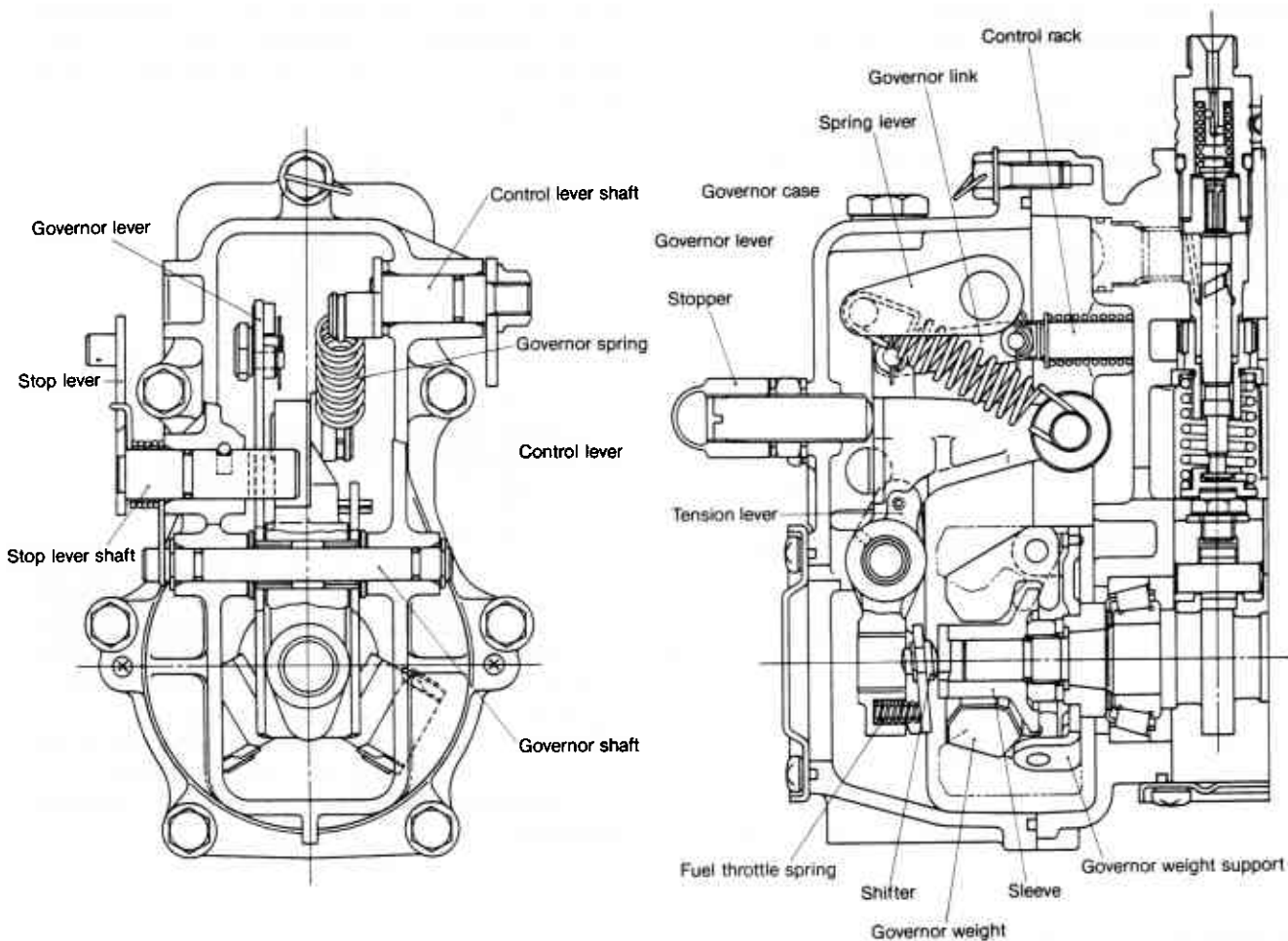

This governor is all-speed, directly connected to the YPES-CL fuel injection pump. The construction will be explained with the cutaway views.

The governor weight mounted on the end of the fuel injection pump cam shaft rotates around the governor support pin, driven by the cam shaft, and is forced outwards by the centrifugal force acting on the weight.

The thrust force acting on the cam shaft due to this centrifugal force acts on the lower part of the tension lever through the sleeve. A starting throttle spring is mounted on the bottom of the tension lever.

One end of the governor spring is hooked to the right upper end of the tension bar, and the other end to the spring lever of the control lever shaft.

As the spring lever and control lever are mounted on the same shaft, when the control lever is turned towards full, the governor spring is pulled and the load gradually increases.

As the lever is turned, the spring force acting on the upper end of the tension lever and the thrust force acting on the lower end of the tension lever come into equilibrium, to obtain the specified rpm.

Since the tension bar can move freely around the governor shaft on the player bearing, as rpm increases and the shifter is pushed to the left, the tension bar rotates clockwise, and when rpm decreases, the tension bar rotates counterclockwise.

The governor lever rotates smoothly on the same governor shaft. The bottom part of this lever is in contact with the sleeve through the shifter, which is in contact with the bottom of the tension lever through the throttle spring. It therefore moves with the tension lever according to increases/decreases in engine rpm.

The top of the governor is connected to the fuel pump control rack by a link. The movement of the lever controls the volume of fuel injected by the pump. When rpm increases the lever rotates clockwise to cause the control rack to reduce fuel, and when rpm decreases the lever rotates counterclockwise to cause the control rack to increase fuel, thus controlling engine rpm.

The top of the tension bar comes in contact with the stopper built into the top of the governor case to limit the maximum fuel injection volume.

**Function of governor
 (on 4JH Series)**

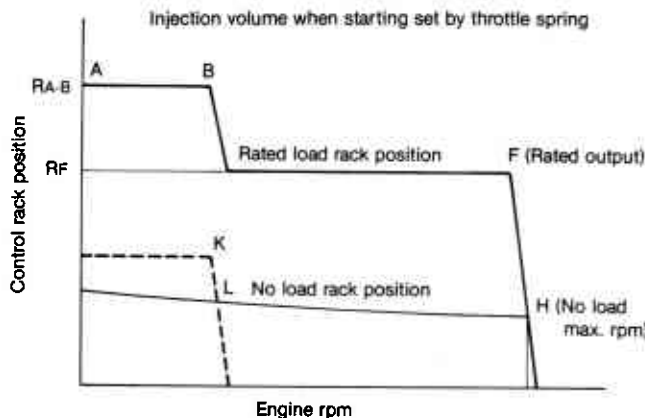

(1) Starting control

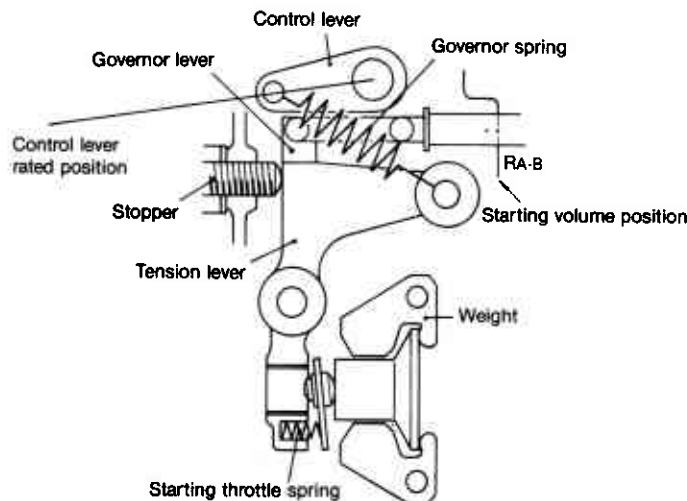

The control lever is set at the max. rpm position. The tension lever connected to the control lever is pulled as far as the stopper. The starting throttle spring mounted inbetween the tension lever and governor lever increases the governor weight thrust load, and the control rack is set at the max. injection volume position, to attain the starting volume.

(2) Idling control

Idling control is effected by the governor spring as this engine is not provided with an idling spring.

When the control lever is returned to the idling position after starting, almost no tension acts on the governor spring. The thrust force of the governor weight, and the starting throttle spring and governor spring load, come into equilibrium, effecting idling speed control.

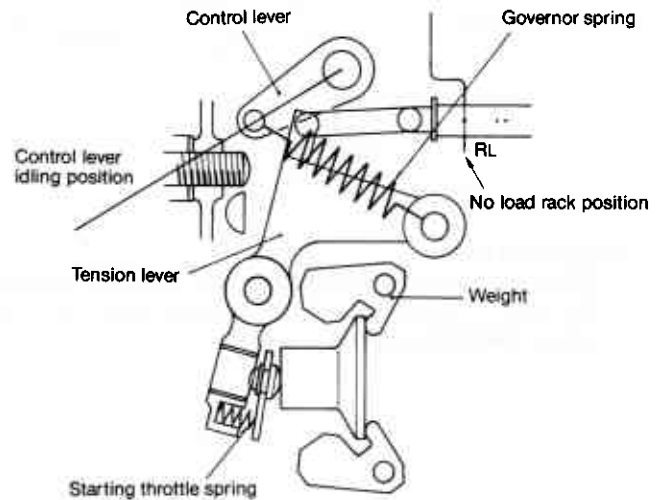

(3) Rated load max. rpm control

At rated load, the thrust load of the governor weight and the governor spring load are in equilibrium. The tension lever and governor lever come together and are limited by the stopper. The control rack is maintained at the position necessary for the rated load.

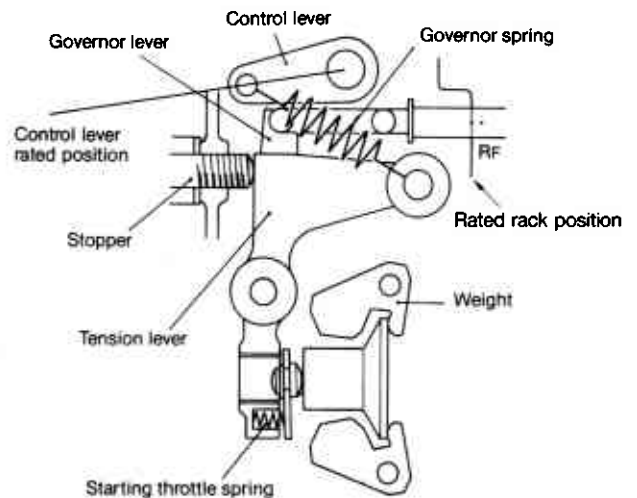

(4) No load max. rpm control

When rpm increases further from the max. load rpm control position, the thrust load of the governor weight exceeds that of the governor spring load, and causes the control rack to decrease injection volume through the tension lever and governor lever.

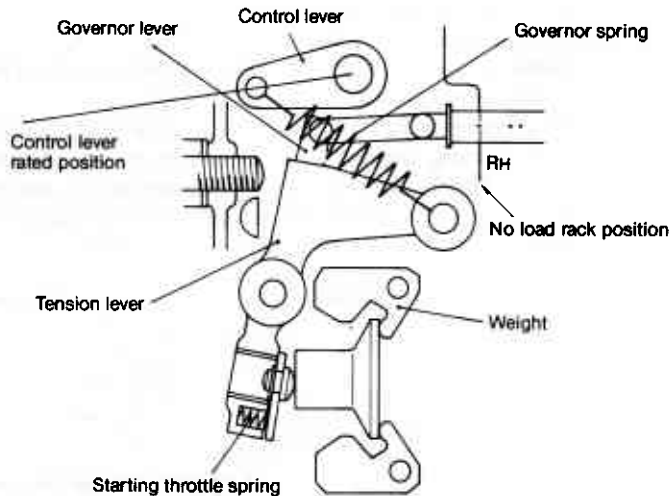

(5) Stopping engine

When you turn the stop handle, the governor causes the rack to decrease injection volume and stop the engine, regardless of the governor spring load.

2. Disassembly, Reassembly and Inspection of Governor

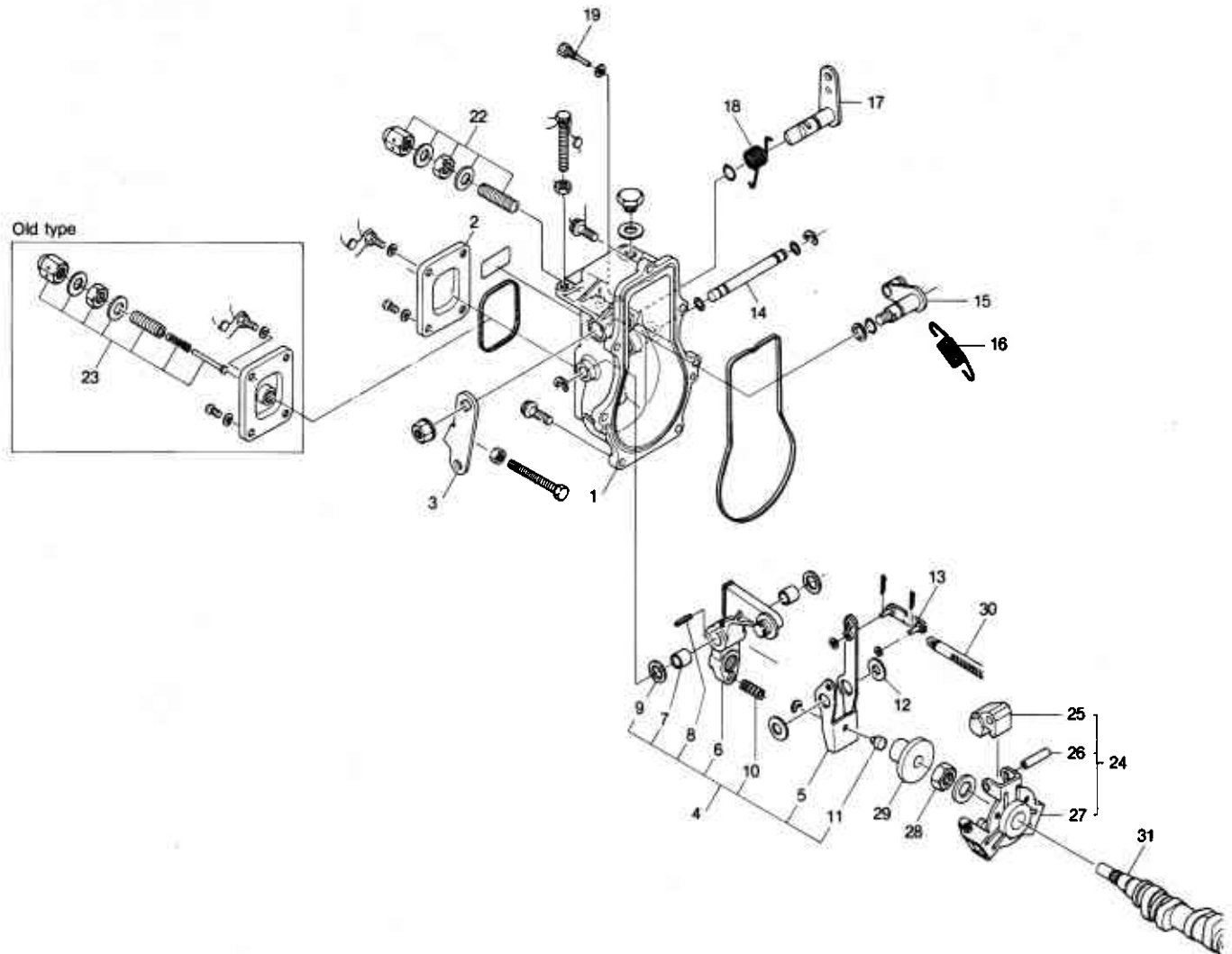

- 1. Governor case
- 2. Governor case cover
- 3. Control lever
- 4. Governor lever assembly
- 5. Governor lever
- 6. Tension lever
- 7. Bushing
- 8. Spring pin
- 9. Shim
- 10. Throttle spring
- 11. Shifter

- 12. Washer
- 13. Governor link
- 14. Governor shaft
- 15. Control lever shaft
- 16. Governor spring
- 17. Stop lever
- 18. Stop lever return spring
- 19. Stop lever stop pin
- 22. Fuel stopper (limit bolt) assembly
- 23. Adjusting spring assembly

- 24. Governor weight
- 25. Governor weight
- 26. Pin
- 27. Governor weight support
- 28. Governor weight nut
- 29. Governor sleeve
- 30. Control rack
- 31. Fuel pump cam shaft

2-1 Governor disassembly

(1) Remove the governor case.

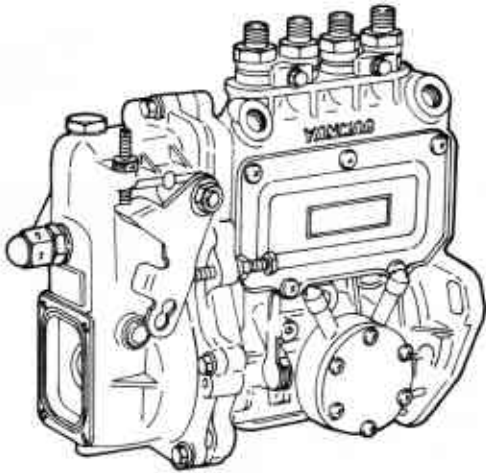

(3) Remove the governor case bolt. Remove the governor case (parallel pin) from the fuel pump unit while lightly tapping the governor case with a wood hammer. Create a gap between the governor case and fuel pump by moving only the moving parts of the governor lever.

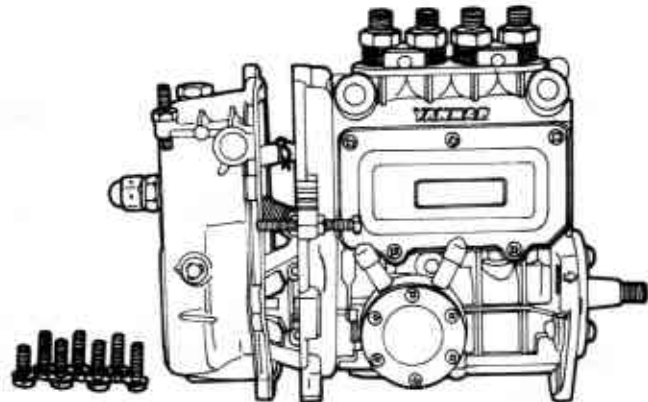

(4) Pull out the governor link snap pin by inserting needle nosed pliers between the fuel pump and governor case.

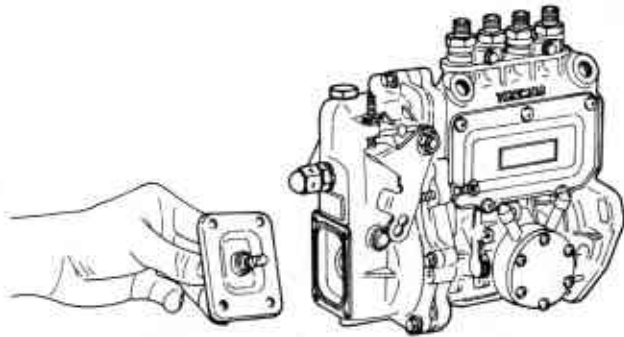

NOTE: Loosen the hex bolt on models with an angleich spring.

(2) Remove the control lever hex nut, and pull out the control lever from the control lever shaft.

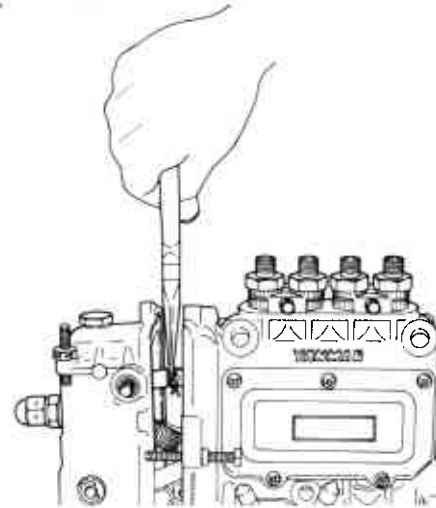

(5) The governor and fuel pump come apart by sliding the governor case and fuel pump apart and pulling out the link pin of the fuel control rack.

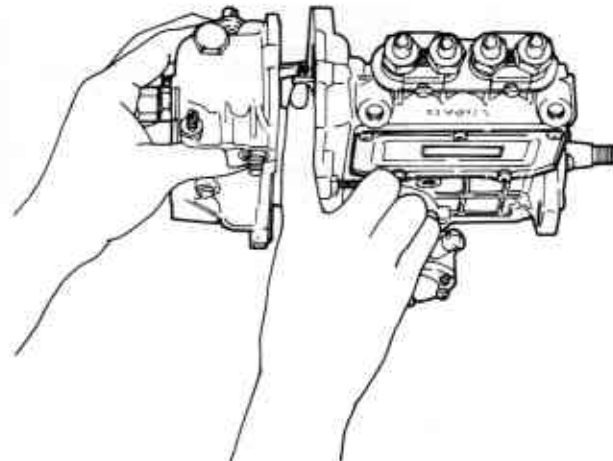
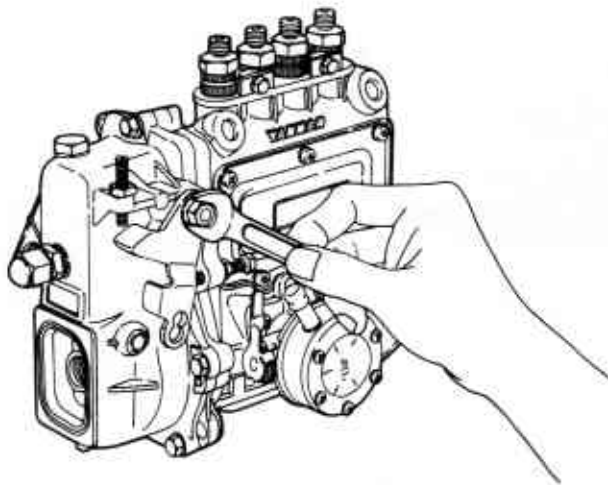

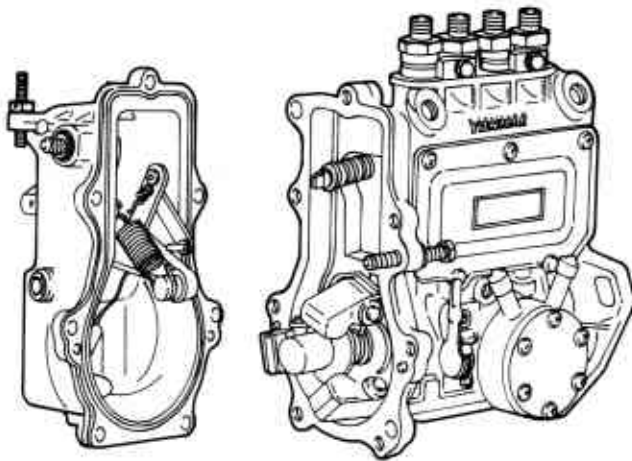

- (6) Remove the stop lever return spring from the governor lever shaft.

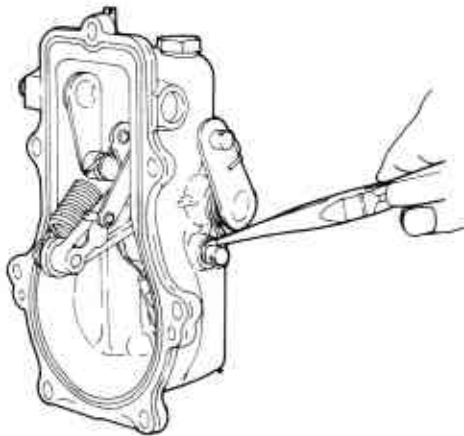

- (7) Use needle nose pliers to unhook the governor spring from the tension lever and control lever shaft.

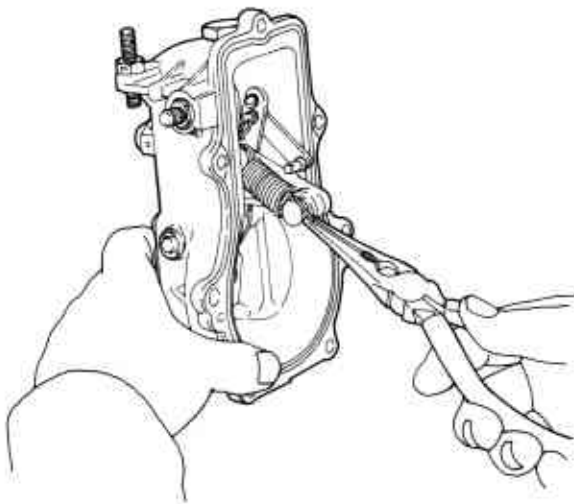

- (8) Remove the snap-rings on both ends of the governor lever shaft.

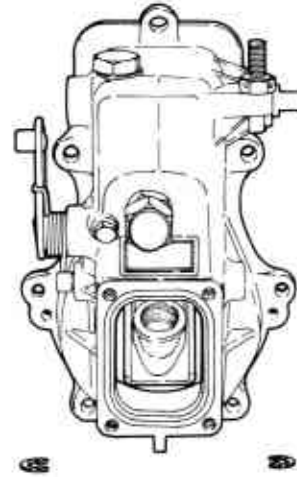

- (9) Put a rod 8mm (0.3150in.) in dia. or less in one end of the governor lever shaft, and tap the governor shaft until the O-ring comes out the other side of the governor case.

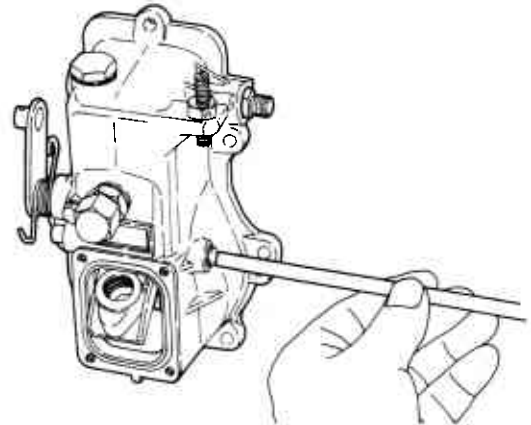

- (10) After you remove the O-ring, lightly tap the end of the shaft that you removed the O-ring from, and remove the governor lever shaft. Then remove the governor shaft assembly and washer.

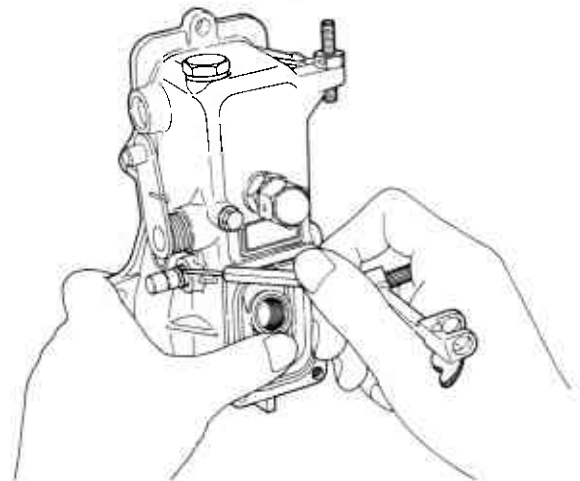

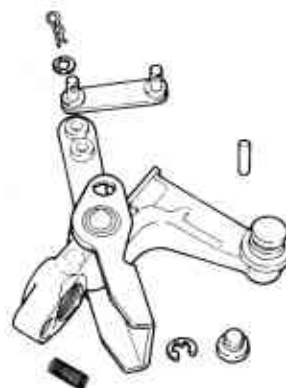
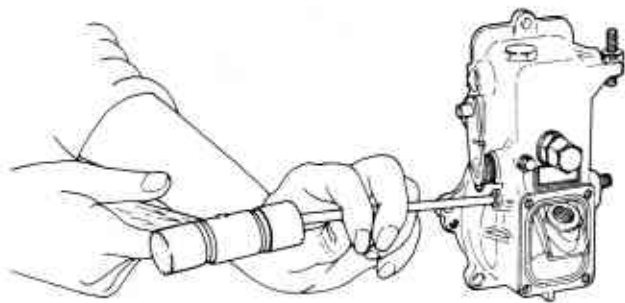

NOTE: The governor assembly consists of the governor lever, tension bar, bushing, throttle spring and shifter, and is normally not disassembled. The spring pin is removed when you replace the shifter or throttle spring.

- (12) When you need to pull out the stop lever, remove the stop lever shaft stop pin, and lightly tap the inside of the governor case.

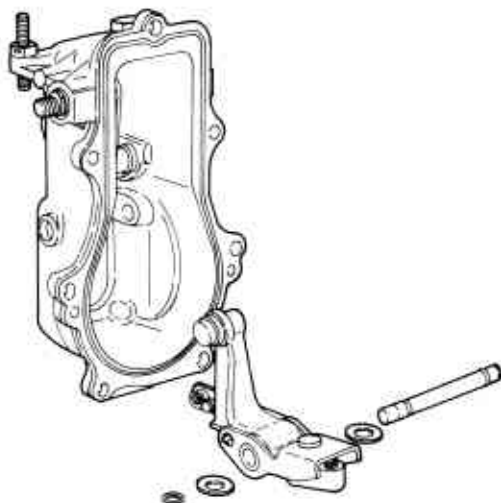

- (11) Remove the governor link from the governor lever.

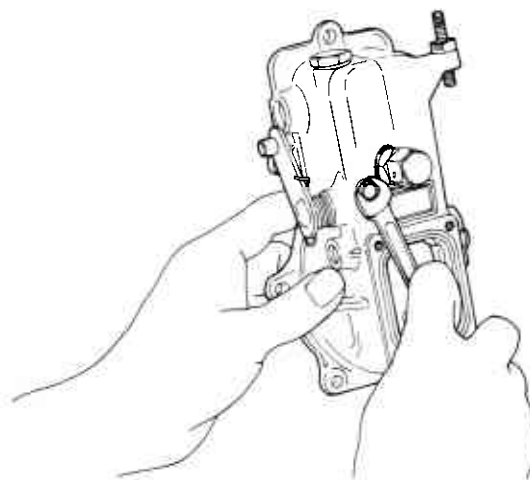

- (13) When you need to pull out the control lever shaft, tap the end of the shaft with a wood hammer.

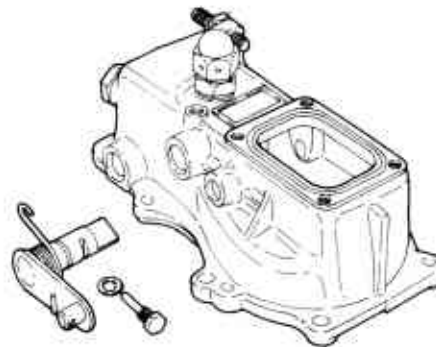
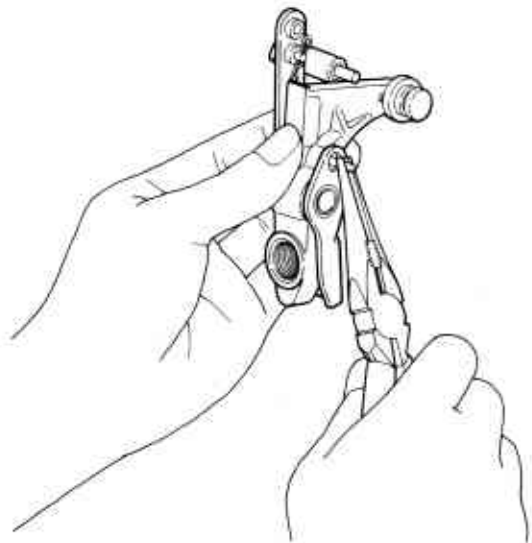

NOTE: 1. Do not remove the fuel limit nut from the governor case unless necessary.

(14) Pull out the governor sleeve on the end of the fuel camshaft by hand.

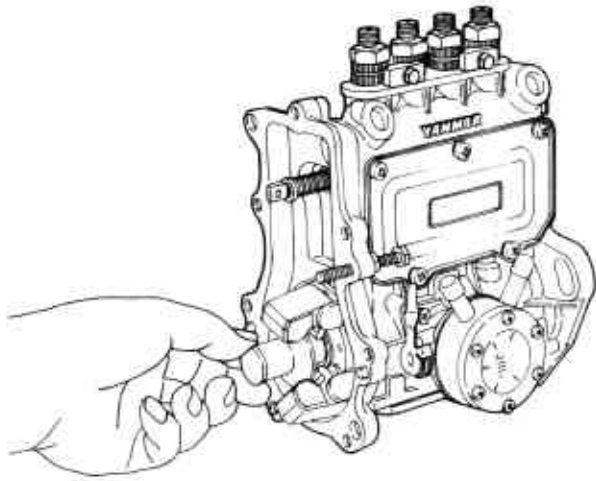

(16) Remove the governor weight assembly from the fuel pump cam using the governor weight pulling tools.

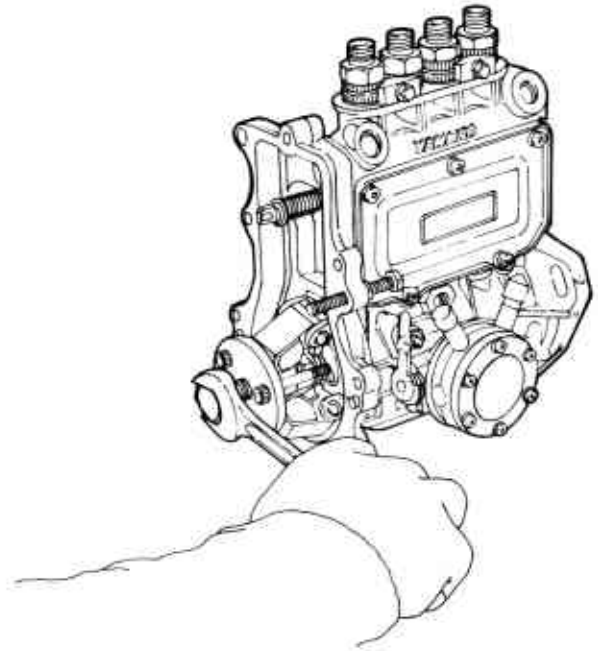

(15) Turn the governor weight with a box spanner two or three times to loosen it, stopping it with the hole in the fuel coupling ring or holding the coupling with a vise.

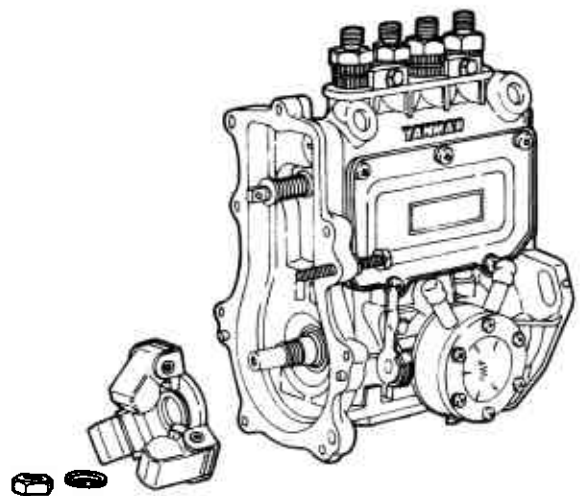
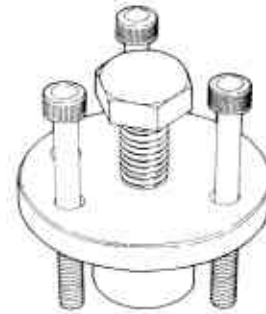
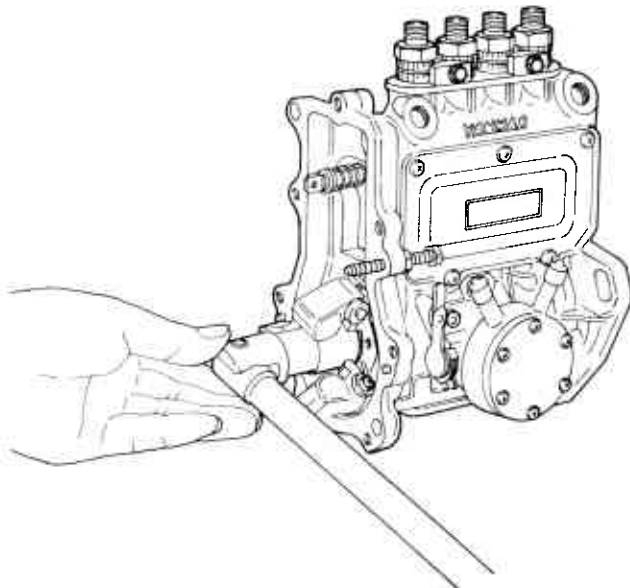

NOTE: When the taper fit comes apart after you have removed the nut, the governor weight may fly out —Be Careful.

NOTE: The governor weight assembly is made up of the governor weight, support and pin. Do not disassemble.

2-2 Inspection of governor

Inspection of governor weight assembly

- (1) Replace the governor weight if it does not open and close smoothly.

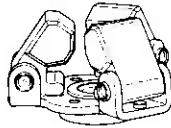

- (2) Replace the governor weight if the contact surface with governor sleeve is extremely worn.
- (3) Replace if there is governor weight support/pin wear or the caulking is loose.
- (4) Replace if the governor weight support stopper is excessively worn.

Inspection of governor sleeve

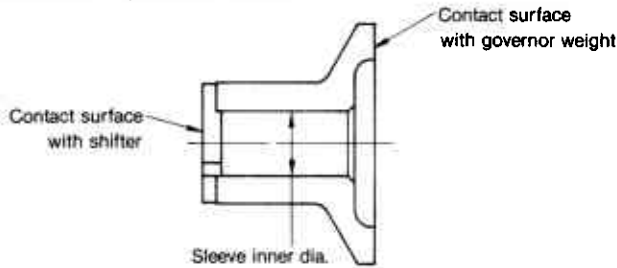

- (1) Replace the governor sleeve if the contact surface with governor weight is worn or there is pitching.
- (2) Replace the governor sleeve if the contact surface with shifter is considerably worn or there is pitching.
- (3) If the governor sleeve does not move smoothly above the cam shaft due to governor sleeve inner dia. wear or other reasons, replace.

Inspection of governor shaft assembly

- (1) Measure the clearance between the governor shaft and bushing, and replace if it exceeds the limit.

mm (in.)			
	Standard Dimension	Standard Clearance	Limit
Governor shaft outer dia.	7.986 ~ 7.995 (0.3144 ~ 0.3147)	0.065 ~ 0.124	0.5 (0.0196)
Bushing inner dia.	8.060 ~ 8.110 (0.3173 ~ 0.3192)	(0.0025 ~ 0.0048)	

- (2) Inspect the shifter contact surface, and replace the shifter (always by removing the pin to disassemble) if it is worn or scorched.
- (3) Disassemble and replace throttle springs that are settled, broken or corroded by pulling the spring pin.
- (4) Check link parts for bends or kinks that will cause malfunctioning, and replace any parts as necessary.

NOTE: 1. Side gap on top of governor lever shaft.

mm (in.)	
Standard side gap	0.4 (0.0157)

2. Replace the governor lever, tension bar, bushing, shifter and throttle spring as an assembly.

(5) Inspection of springs

- 1) Check the governor spring and other springs and replace if they are broken, settled or corroded.
- 2) Measure the free length of the governor spring, and replace if it exceeds the limit.
See service data sheet for free length of governor spring.

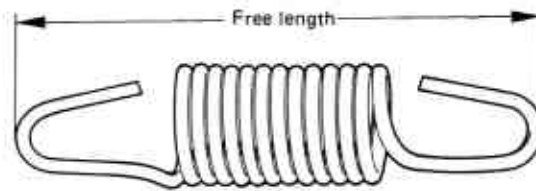

Governor spring spec. table

Engine model	4JHE, 4JH-TE	4JH-HTE, 4JH-DTE
Part No.	129470-61700	129473-61700
Spring constant	kg/mm 0.479	0.431
Free length	mm 54.0	52.5

2-3 Assembling governor

Inspect all parts after disassembly and replace any parts as necessary. Before starting reassembly, clean new parts and parts to be reused, and put them in order. Make sure to readjust the unit after reassembly to obtain the specified performance.

- (1) Insert the governor weight assembly in the taper portion at the end of the fuel pump camshaft, stopping it with the hole in the fuel coupling ring or holding the coupling with a vise, mount the rest, and tighten the governor weight nut.

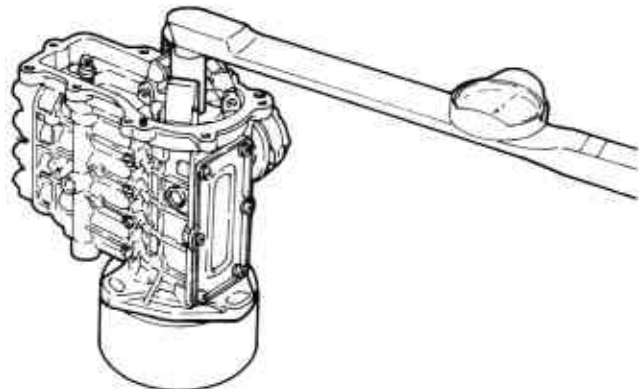

kg-m (ft-lb)	
Governor weight nut tightening torque	4.5 ~ 5.0 (32.54 ~ 36.16)

- (2) Open the governor weight to the outside, and insert the sleeve in the end of the fuel pump camshaft.

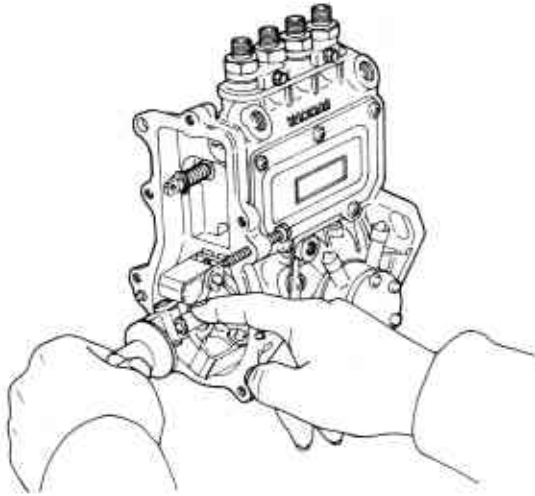

NOTE: Make sure that the sleeve moves smoothly after inserting it.

- (3) When the stop lever has been disassembled, mount the stop lever return spring on the stop lever, tap the stop lever lightly with a wooden hammer to insert it, and tighten the stop lever stop pin.

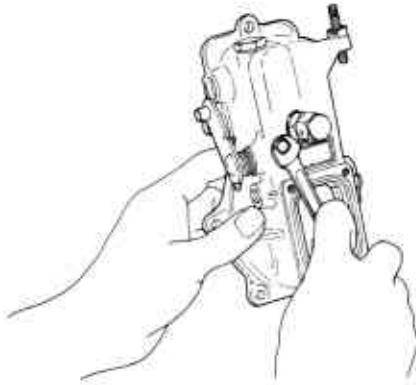

- (4) When the control lever shaft has been removed, lightly tap the control lever shaft and washer from inside the governor case, using an appropriate plate.

- (5) If the governor has been disassembled, tap in the spring pin.

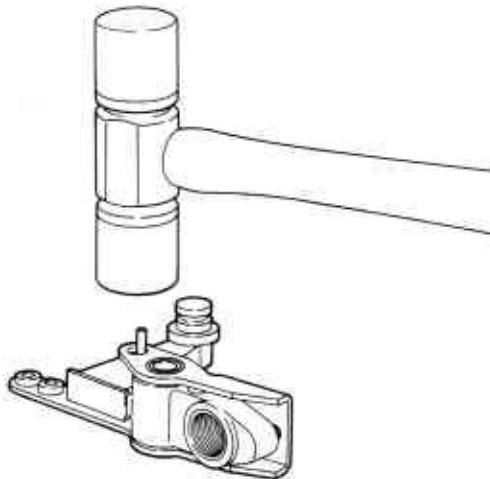

- (6) Mount the governor lever assembly to the governor link.

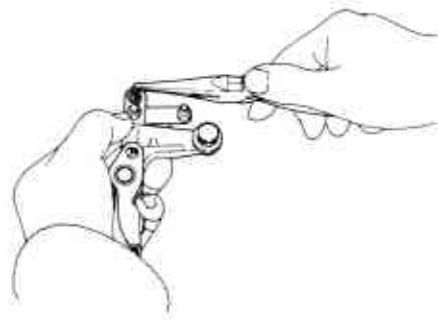

NOTE: 1. Make sure that the correct governor link mounting holes are used, and that it is mounted in the correct direction.

2. Make sure that the governor link moves smoothly.

- (7) Put the governor lever shaft assembly in the governor case, insert the governor lever shaft, and tap it in until the O-ring groove comes out the opposite side of the governor case.

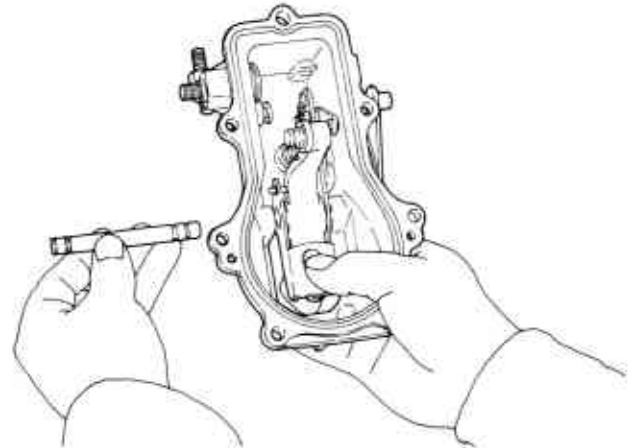

NOTE: 1. Fit the O-ring to the side you have tapped in.

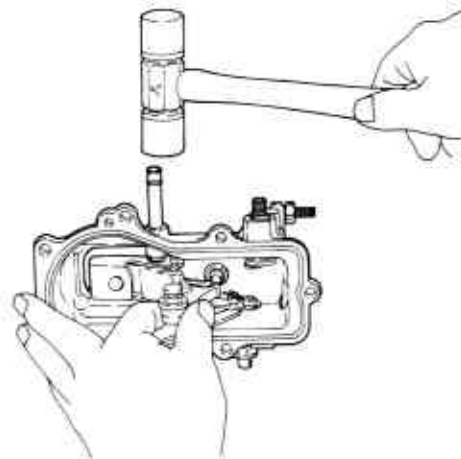

2. Make sure to insert the governor lever shaft in the correct direction.

3. Don't forget to mount the washers to both sides of the governor lever.

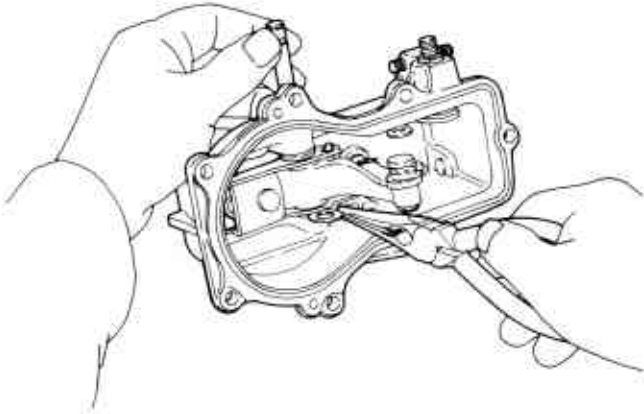

(8) After you have mounted the O-ring, tape the governor lever in the opposite direction, and mount the E-shaped stop rings on the grooves at both ends.

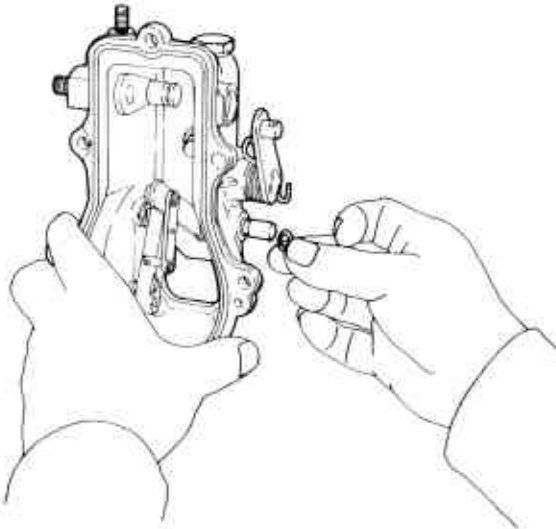

(9) Fit the stop lever return spring to the end of the governor lever shaft.

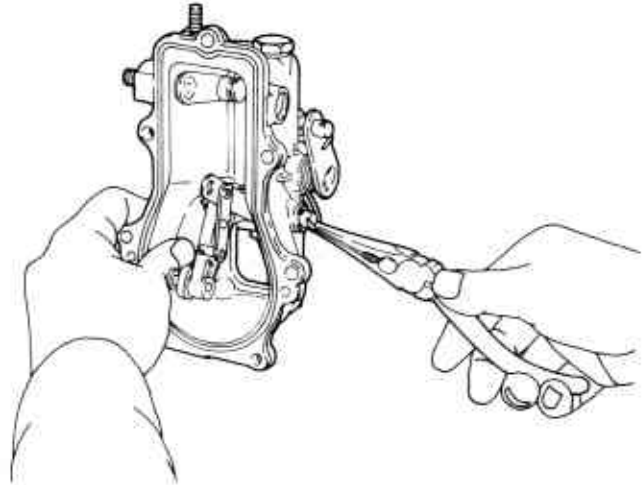

(10) Hook the governor spring on the control lever shaft and tension lever hook with radio pliers.

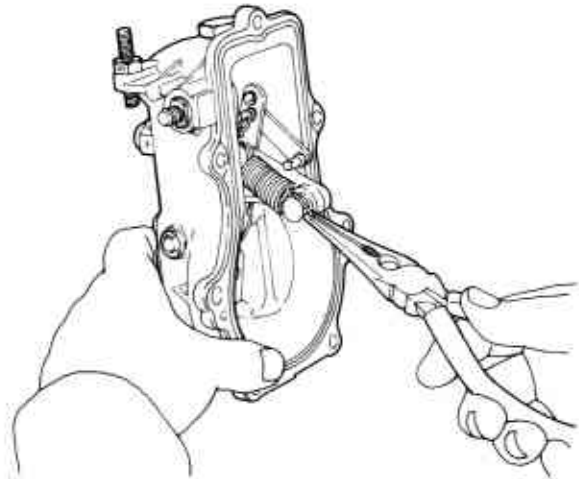

(11) Pull the governor link as far as possible towards the governor case mounting surface, insert the governor link pin in the fuel control rack pin hole and fit the snap pin on it.

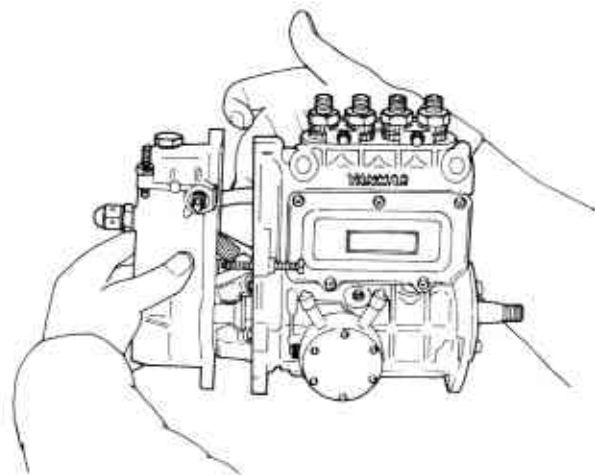
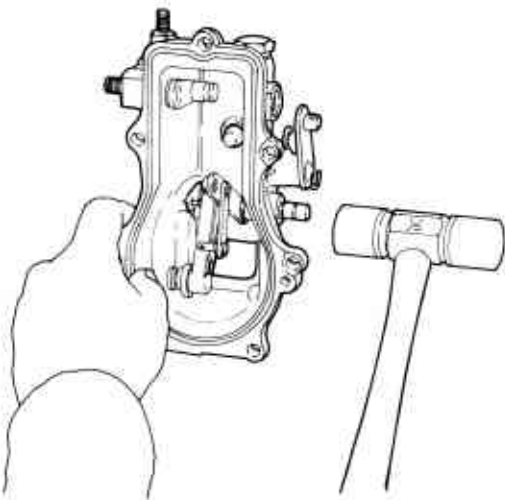

NOTE: After mounting the governor lever assembly, make sure the governor lever assembly moves smoothly.

- (12) Mount the governor case to the fuel pump unit while lightly tapping it with a wooden hammer, and tighten the bolts.
- (13) Place the adjusting spring and adjusting rod on the governor case cover adjusting bolt, and mount the governor case cover.

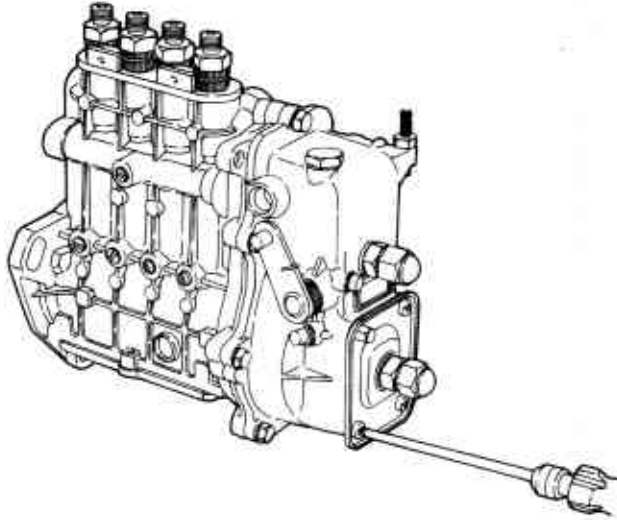

- (14) Insert the control lever in the control lever shaft, and tighten the nut.

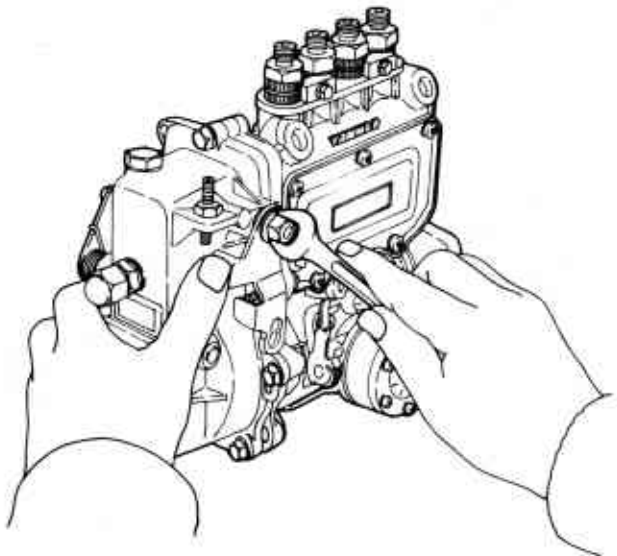

NOTE: Move the control lever back and forth to make sure that the entire link moves smoothly.

3. Disassembly, Reassembly and Inspection of Fuel Injection Pump

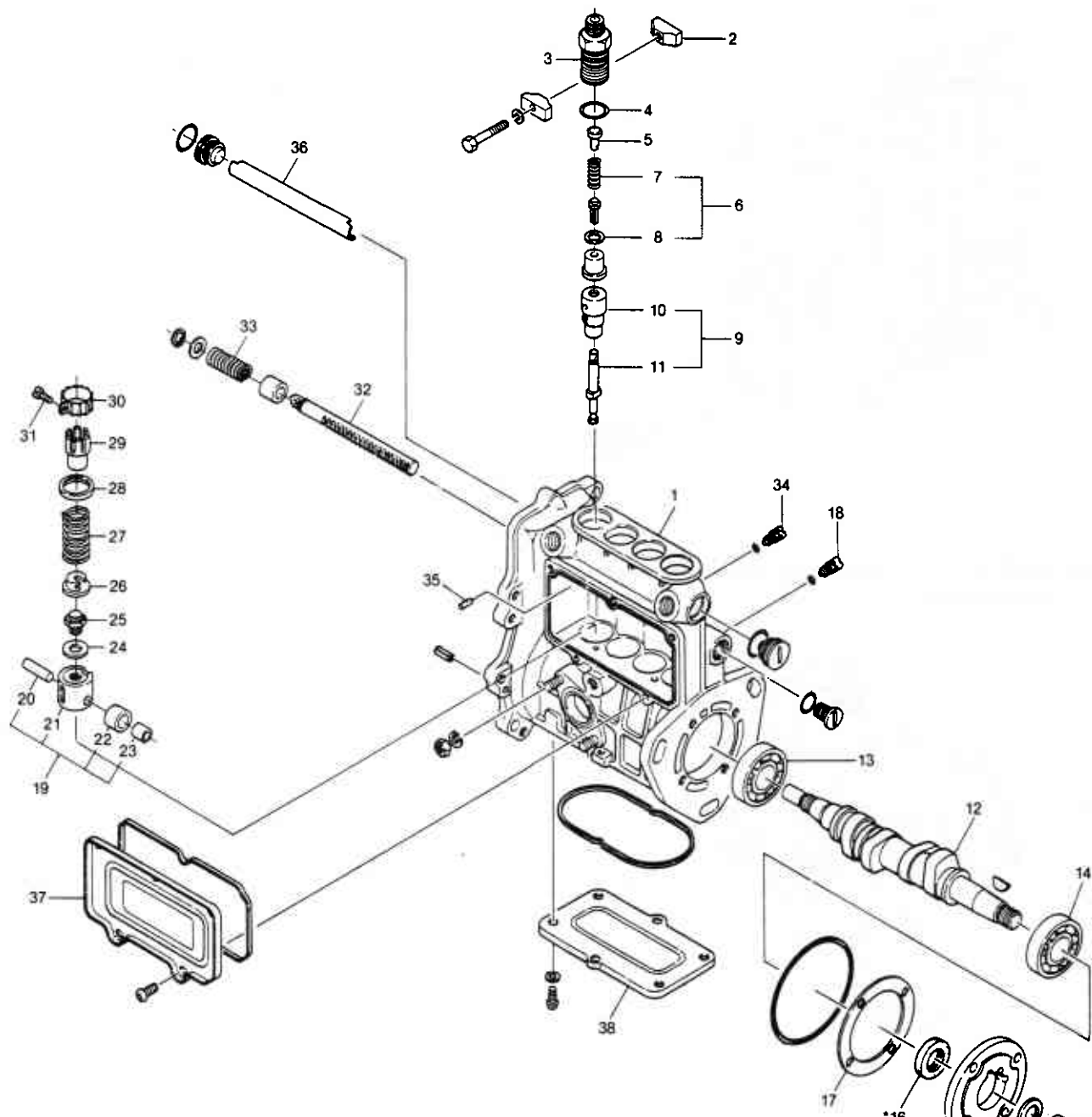

- 1. Fuel pump unit
- 2. Delivery valve retainer stop
- 3. Delivery valve retainer
- 4. Delivery valve stopper
- 5. Delivery valve spring
- 6. Delivery valve assembly
- 7. Delivery valve
- 8. Delivery valve seat
- 9. Plunger assembly
- 10. Plunger barrel
- 11. Plunger
- 12. Fuel pump camshaft
- 13. Bearing
- 14. Bearing
- 15. Bearing holder
- 16. *Oil seal
- 17. Adjusting packing (shim)
- 18. Tappet stopper
- 19. Tappet assembly
- 20. Pin
- 21. Roller guide
- 22. Roller (outer)
- 23. Roller (inner)
- 24. Adjusting shim
- 25. Adjusting bolt
- 26. Plunger spring rest B
- 27. Plunger spring
- 28. Plunger spring rest A
- 29. Control sleeve (reduction ring)
- 30. Control pinion B

- 31. Stop screw
- 32. Aux. spring
- 33. Control rack stopper
- 34. Plunger barrel stopper
- 35. Deflector
- 36. Pump side cover
- 37. Pump bottom cover

NOTE: 1. Some models are equipped with ball bearings and some with taper roller bearings.
 2. *Oil seal: Some models are equipped with oil seals and some are not. The shape of the bearing holder differs for models with and without oil seals.

3-1 Disassembly of fuel injection pump

When disassembling the fuel pump, separate the parts for each cylinder and be careful not to get them mixed up. Be especially careful to keep the plunger/plunger barrel, delivery valve/delivery valve seat and other assemblies separate for each cylinder (the parts of each assembly must be kept with that assembly and put back in the same cylinder).

Preparation

1. Wash off the dirt and grease on the outside of the pump with cleaning oil (kerosene or diesel oil) before disassembly.
2. Perform work in a clean area.
3. Take off the fuel pump bottom cover and remove lubricant oil.
4. Turn the fuel pump upside down to drain fuel oil.

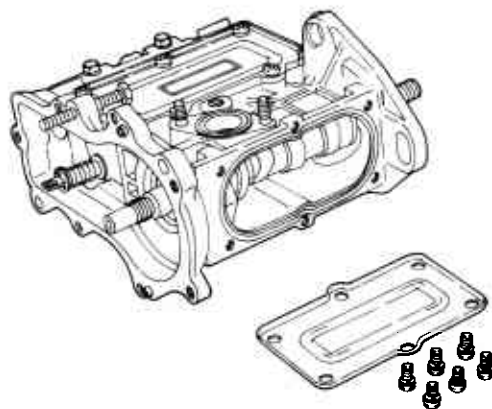

- (1) Loosen the nut with a box spanner and take it off, holding it with the hole in the fuel coupling ring or holding the coupling with a vise and take out the governor weight assembly.

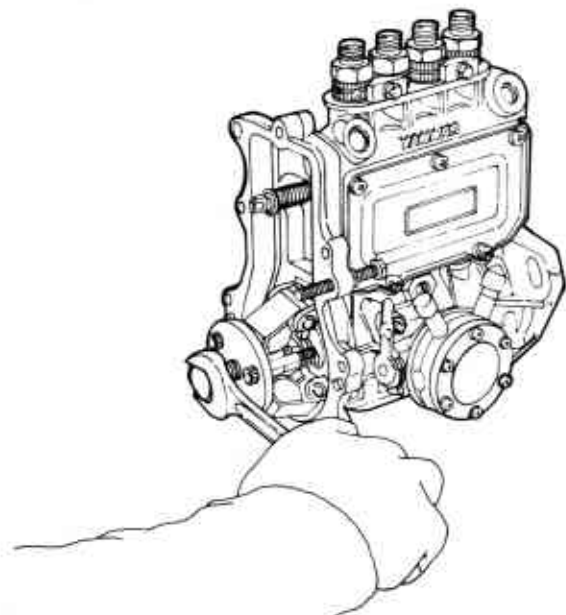

- (2) Remove the fuel feed pump.

NOTE: Do not disassemble the fuel feed pump. See instructions for fuel feed pump for details.

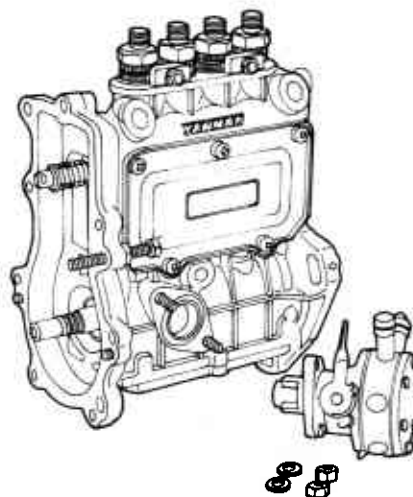
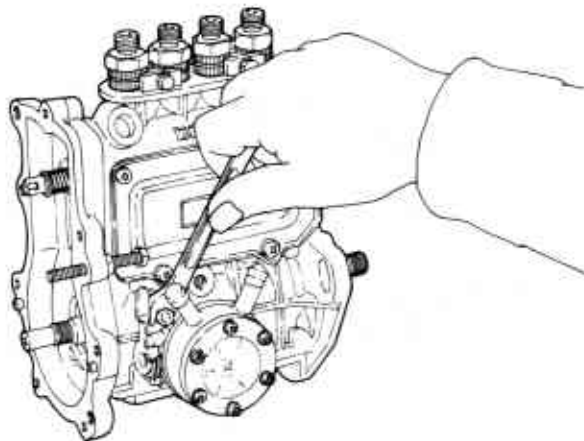

- (3) Remove the fuel pump side cover.

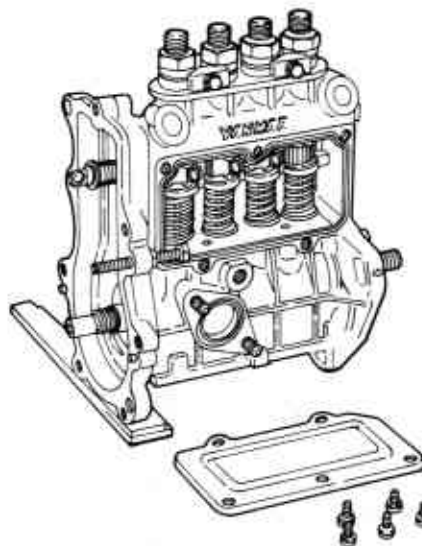

- (4) Turn the camshaft until the roller guide is at the maximum head, and insert the plunger spring support plate in between the plunger spring washer B (lower side) and fuel pump unit.

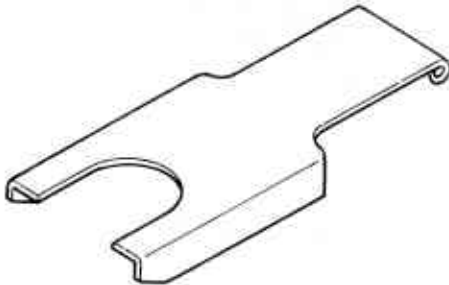
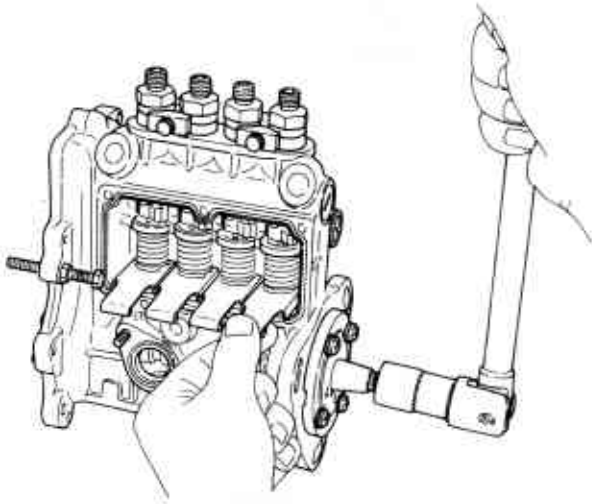

Plunger spring support plate

NOTE: If the camshaft does not turn, put double nuts on the end of the cam shaft or remove the coupling.

- (5) Remove the camshaft wood ruff key.
(6) Put a screwdriver in the two grooves on the camshaft bearing holder mounting surface, and pull out the camshaft bearing holder.

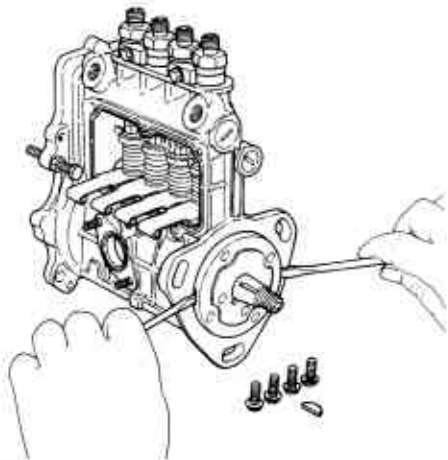

NOTE: 1. Make sure not to damage the oil seal with the threaded part of the camshaft.
2. Be careful not to loose the shims in between the pump and bearing holder.

- (7) Turn the fuel pump upside down, move all the roller guides to the plunger side, and then put the pump on its side. Turn the camshaft to a position so that none of the cylinder cams hit the tappets.
(8) Put a plate against the governor end side of the camshaft and lightly tap it, and pull out the camshaft and drive side bearing.

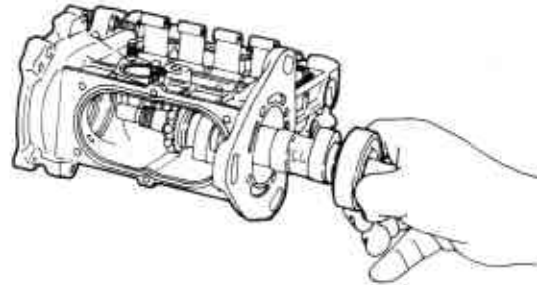

- (9) Remove the roller guide stop.

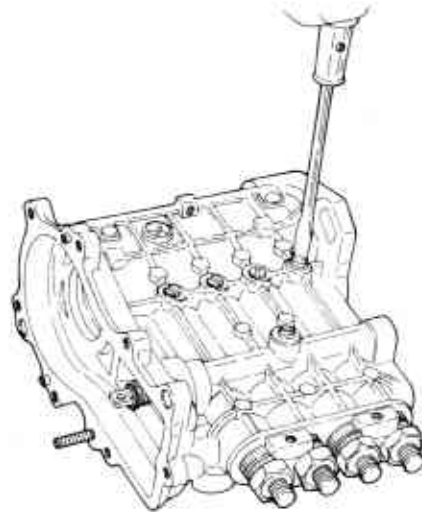

- (10) Use a hammer handle or the like to push up the roller guide from the bottom of the pump, and remove the plunger support plate.

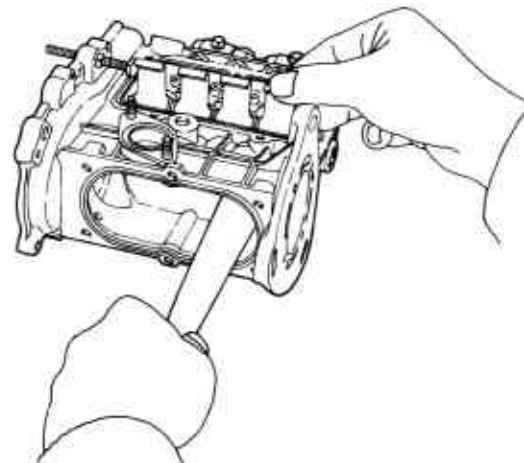

NOTE: The plunger spring may make the roller guide and plunger, etc. fly out when the plunger support plate is removed.

(11) Remove the roller guide.

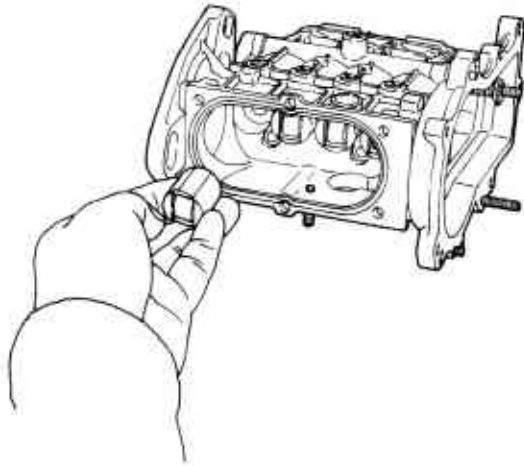

NOTE: When you stand the fuel pump up, all of the roller guides drop out at one time. Therefore, first remove the stop bolt for one cylinder at a time, and then the roller guide for each cylinder—continue this process.

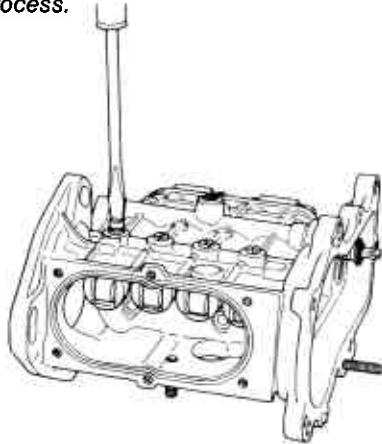

(12) Remove the plunger, plunger spring and lower washer from the lower part of the pump.

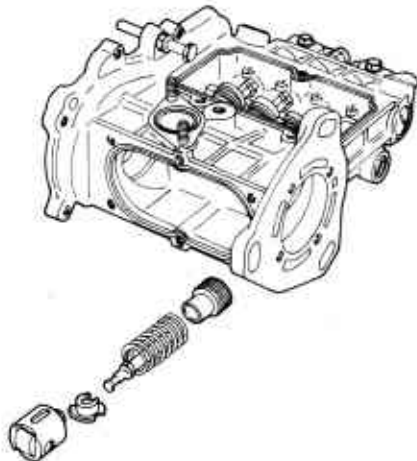

NOTE: Keep the parts separate for each cylinder.

(13) Loosen the small screw on control pinion.

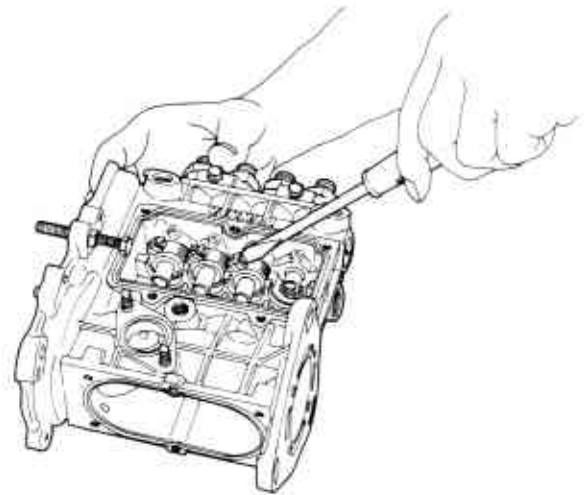

NOTE: 1. Check to make sure the match marks on the pinion/sleeve are correct before loosening the small screw on the control pinion, as the pinion and sleeve come apart when the screw is loosened. If the mark is hard to read or off center, lightly inscribe a new mark. This will serve as a guide when adjusting injection volume later.

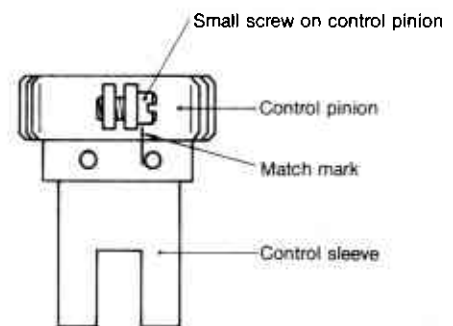

2. Keep parts separate for each cylinder.

(14) Remove the control pinion, sleeve and upper rest.

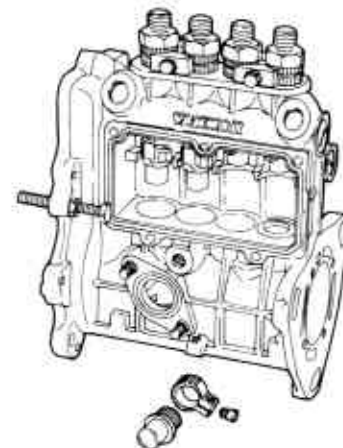

NOTE: Keep parts separate for each cylinder.

- (15) Remove the control rack stop bolt and remove the rack.

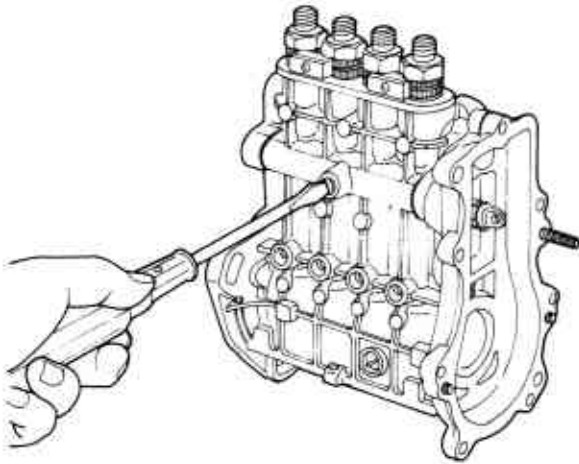

- (17) Remove the delivery valve holder.

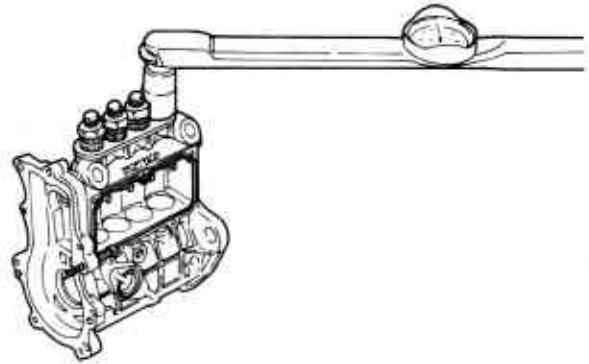

NOTE: Be careful not to lose the spring or rest on the control rack.

- (18) Remove the delivery valve assembly.

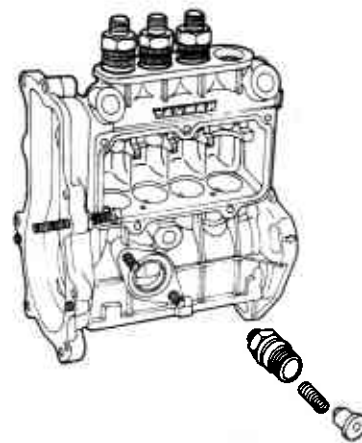
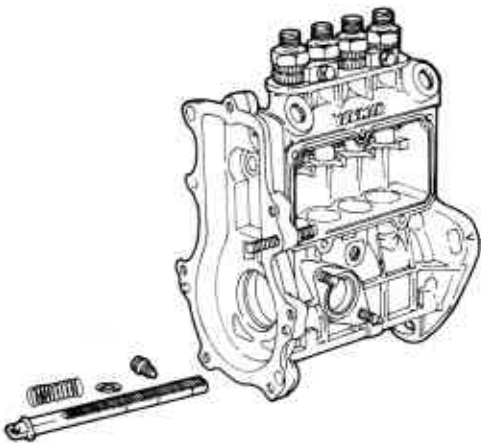

NOTE: 1. Be careful not to lose the delivery valve packing, delivery valve spring, delivery valve stopper or other small parts.
2. Keep the delivery valve assemblies for each cylinder clearly separated.

- (19) Take the plunger barrel out from the top of pump.

- (16) Loosen the delivery valve retainer stop bolt, and remove the delivery valve holder stop.

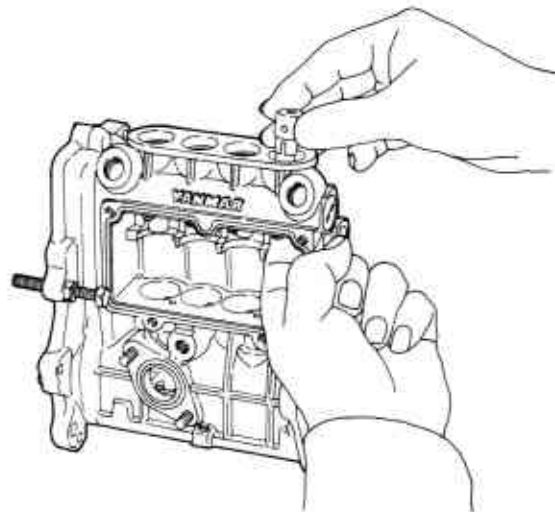
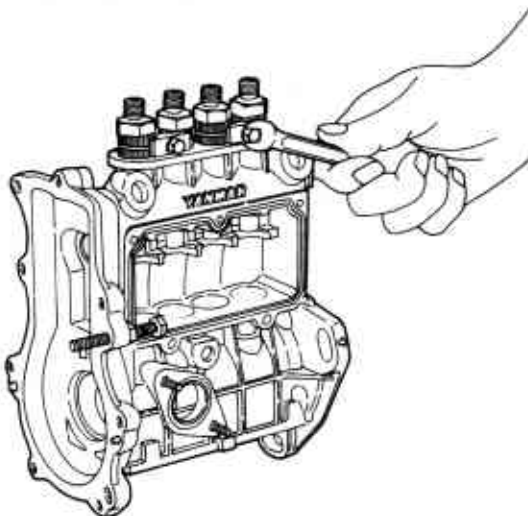

NOTE: Keep it as a set with the plunger that was removed earlier.

3-2 Inspection of fuel injection pump

(1) Inspection of plunger

- 1) Thoroughly wash the plungers, and replace plungers that have scratches on the plunger lead or are discolored.
- 2) The plunger is in good condition if it slides down smoothly when it is tilted about 60°. Repeat this several times while turning the plunger. Repair or replace if it slides down too quickly or if it stops part way.

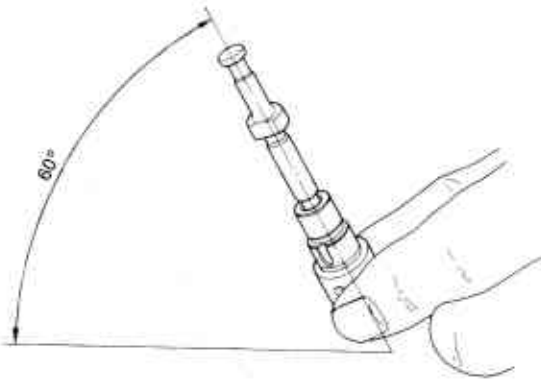

(2) Inspection of delivery valve

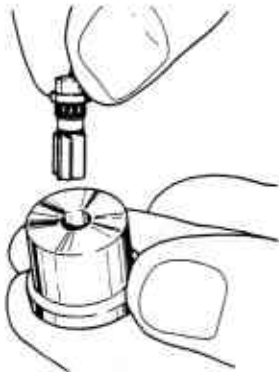

- 1) Replace as a set if the delivery valve suck-back collar or seat are scratched, scored, scuffed, worn, etc.
- 2) The valve is in good condition if it returns when released after being pushed it down with your finger (while the holes in the bottom of the delivery guide seat are covered). Replace if necessary.
- 3) Likewise, the valve should completely close by its own weight when you take your finger off the holes in the bottom of the delivery guide sheet.

NOTE: When fitting new parts, wash with diesel oil and perform the above inspection.

(3) Inspection of pump

- 1) Inspect for extreme wear of roller guide sliding surface. Scratches on the roller pin sliding surface are not a problem.
- 2) Inspect the plunger barrel seat.
If there are burrs or discoloration, repair or replace as this will lead to dilution of the lubricant.
- (4) Inspection of fuel camshaft and bearings
 - 1) Fuel camshaft
Inspect for scratches or wear of camshaft, deformation

of key grooves and deformation of screws on both ends, and replace if necessary.

2) Bearings

Replace if the taper rollers or outer race surface is flaked or worn.

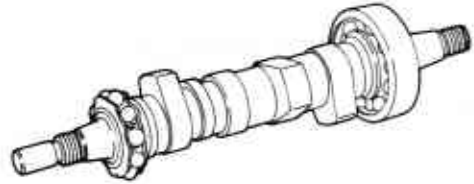

NOTE: Replace fuel camshafts and bearings together.

(5) Inspection of roller guide assembly

1) Roller



Replace if the surface is worn or flaked.

2) Roller Guide

Replace if the outer roller pin hole is extensively worn or there are many scratches.

3) Replace if the play of the roller guide assembly pin/roller is 0.2mm (0.0078in.) or more.

4) Injection timing adjustment bolt

Replace if the surface in contact with the plunger side is unevenly or excessively worn.

(6) Inspection of rack and pinion

1) Rack

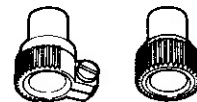

Inspect for bending of rack and wear or deformation of fit with pinion.

2) Pinion

Inspect for wear or deformation of fit with rack.

NOTE: If the tooth surface or sliding surface is not in good working order, rack resistance increases, affecting the condition of the engine (rough rpm, over running, etc.).

(7) Inspection of plunger spring and delivery spring

Inspect springs for scratches, cracks, breakage, uneven wear and rust.

- (8) Inspection of oil seals
Inspect oil seals to see if they are burred or scratched.
- (9) Inspection of roller guide stop
Inspect the side of the tip, replace if excessively worn.
- (10) Inspection of O-rings
Inspect and replace if they are burred or cracked.

3-3 Reassembly of fuel injection pump

Preparation

After inspection, put all parts in order and clean.
See Inspection of Fuel Pump for inspection procedure.

- (1) Put in the plunger barrel from the top of pump.

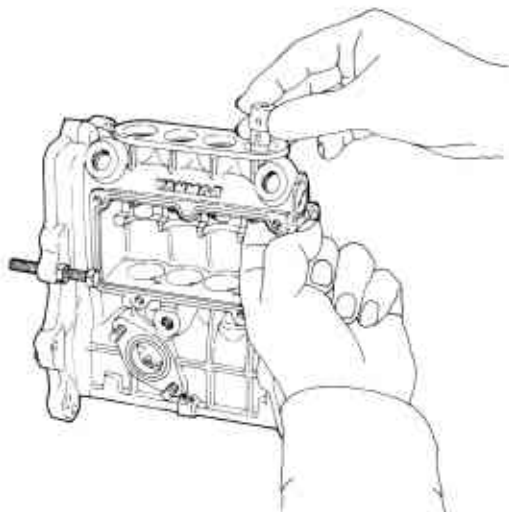

NOTE: Make sure the barrel key groove is fitted properly to the barrel stop pin.

- (2) Place the delivery valve assembly, packing, spring and stopper from the top of the pump, in this order.

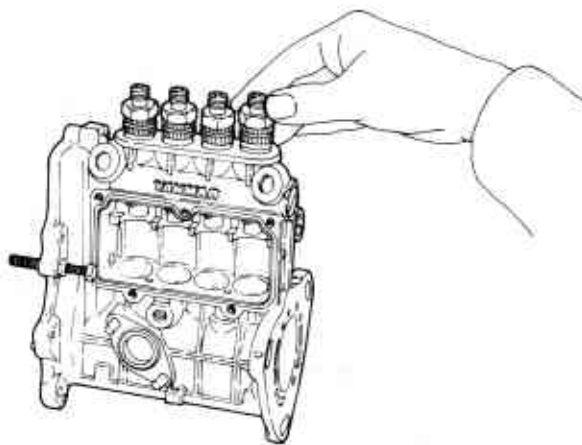

NOTE: Replace the delivery valve packing and O-ring.

- (3) Place the control rack, and tighten the control rack stop bolt.

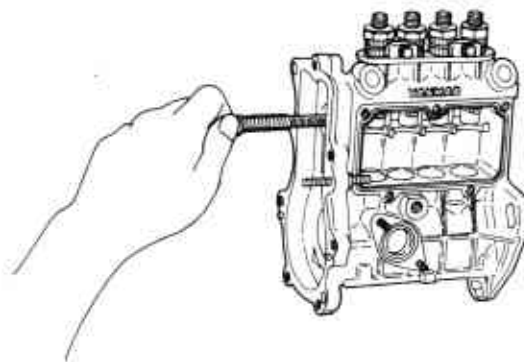

NOTE: 1. Do not forget the rack aux. spring.
2. Make sure the rack moves smoothly through a full cycle.

- (4) Place the rack set screw (using the special tool) in the rack stop bolt screw hole to fix the rack.
- (5) Looking from the bottom of pump, align the match marks on the rack and pinion.

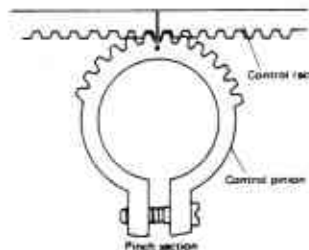

- (6) While holding the pinion with one hand and keeping it aligned with the match mark, fit in the sleeve, and lightly tighten the small pinion screw.

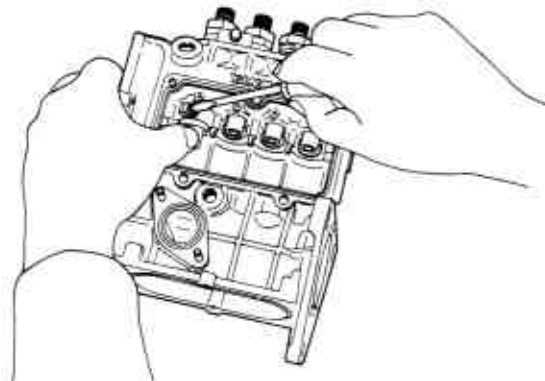

NOTE: Fitting of sleeve; Face towards small pinion screws and align with match mark.

Pinion/sleeve match mark

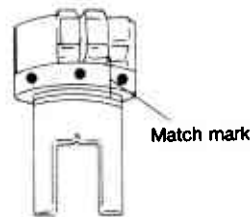

(7) Mount the plunger spring upper rest.

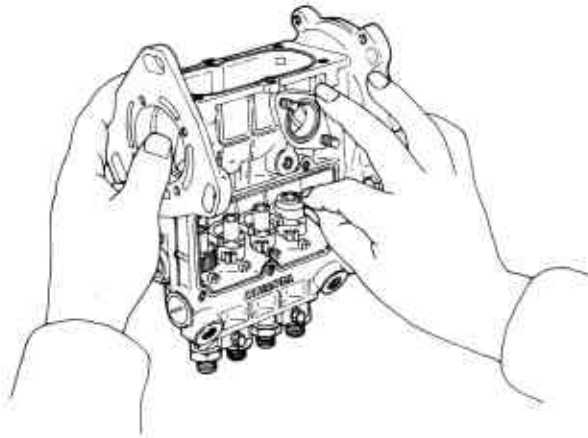

NOTE: 1. Make sure to mount the upper rest with the hollow side facing down.
2. Recheck to make sure that the rack moves easily.

(8) Mount the plunger spring.

(9) Mount the lower rest on the head of the plunger, and fit the plunger in the lower part of pump while aligning the match marks on the plunger flange and the sleeve.

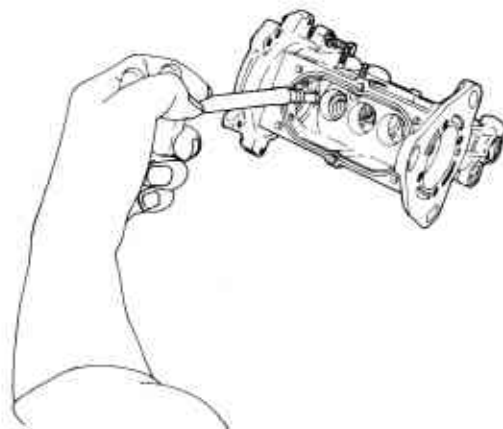

Plunger inserting tool

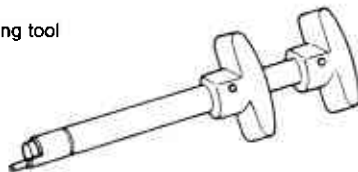

NOTE: If the plunger is mounted in the opposite direction, the injection volume will increase abnormally and cannot be adjusted.

(10) Insert the plunger spring support plate between the plunger spring seat B (lower) and fuel pump, by putting the handle of a hammer in the lower part of pump and pushing the roller guide up.

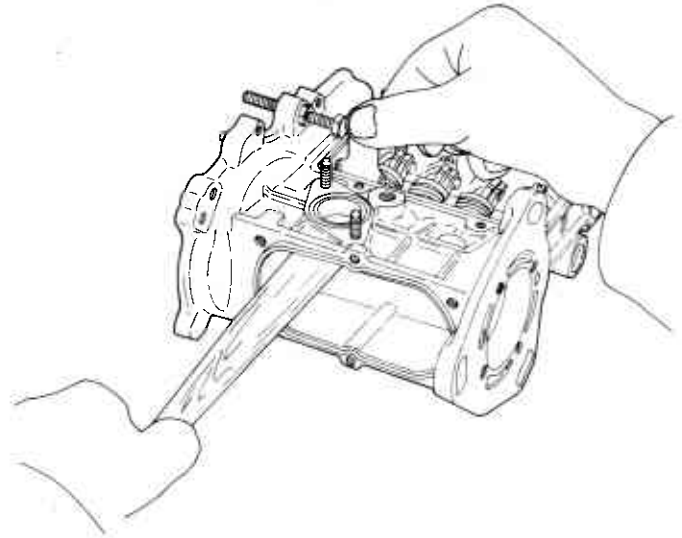

NOTE: 1. Face the roller guide stop groove up, and align with stop screw hole on pump.

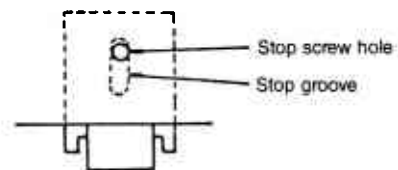

2. Check movement of rack. The plunger spring may be out of place if movement is heavy—insert a screwdriver and bring to correct position.

3. When replacing the roller guide assembly, fit shims and lightly tighten:

Standard shim thickness	1.2 mm (0.0472 in.)
Part code number	129155-51600

(11) Make sure that roller guide stop groove is in correct position, and tighten roller guide stop bolt.

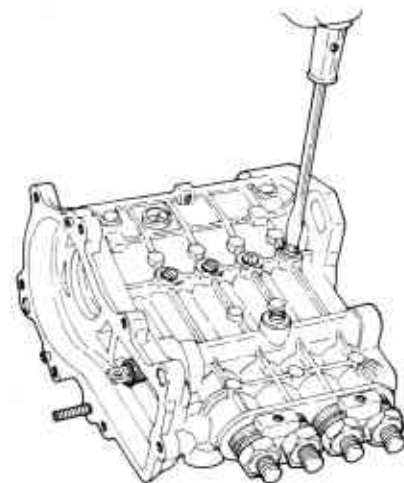

- (12) Fit the bearings to both ends of the camshaft, and insert from drive side by lightly tapping.

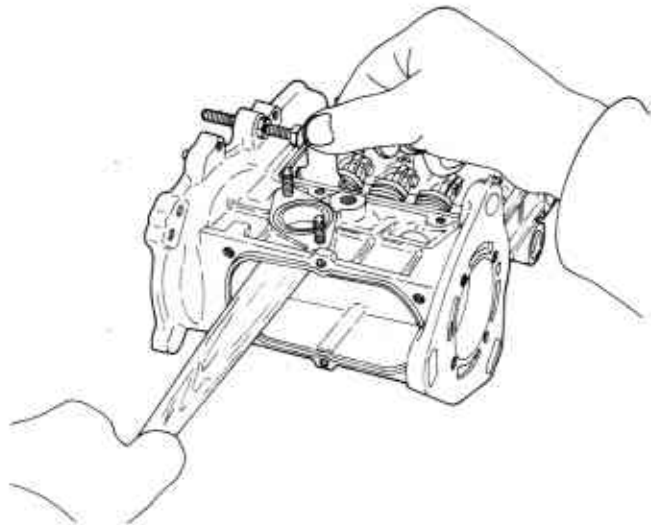
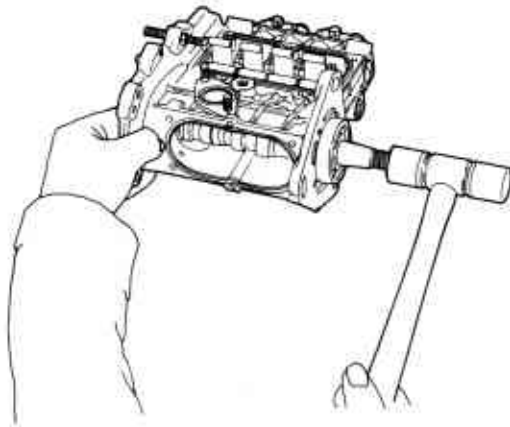

NOTE: Turn pump upside down, and tap camshaft in while moving roller guide to plunger spring side.

- (13) Fit the oil seal on the inside of the bearing retainer and mount the bearing retainer.

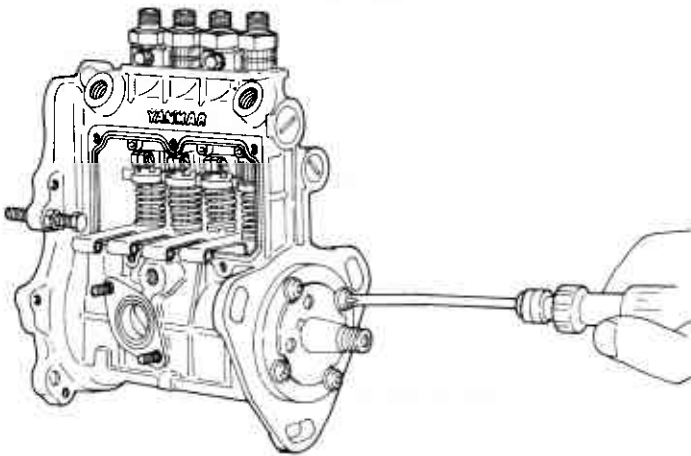

- (15) Mount the fuel pump side cover.
 (16) Tap in the camshaft wood ruff key.
 (17) Turn the camshaft, and pull out the plunger spring support plate.

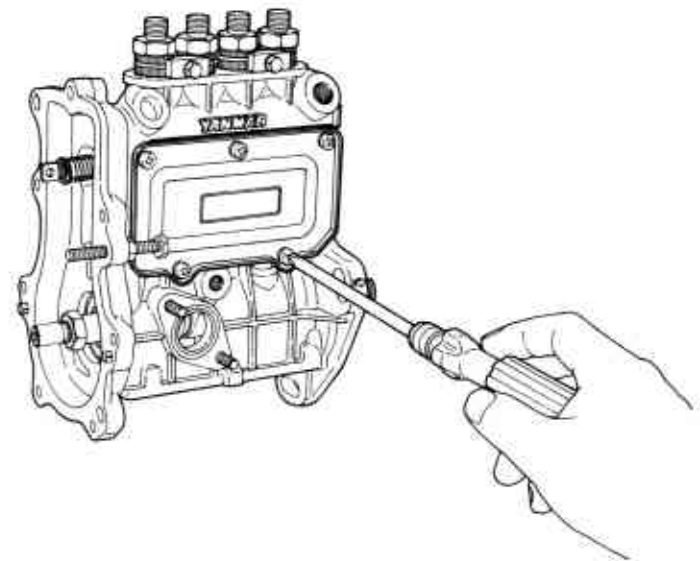

NOTE: Coat the camshaft and oil seal with oil to prevent the oil seal from being scratched.

- (14) Fix the pump, lightly tap both ends of the cam shaft with a wood hammer, and adjust the cam shaft side clearance with the adjustment shims while checking with side clearance gauge.

	mm (in.)
Camshaft side clearance	0.02 ~ 0.05 (0.0007 ~ 0.0019)

Adjusting

Pull out adjusting shims if clearance is too small, and add adjusting shims if it is too large.

	mm (in.)
Adjusting shim thickness	0.50 (0.0196)
	0.40 (0.0157)
	0.30 (0.0118)
	0.15 (0.0059)

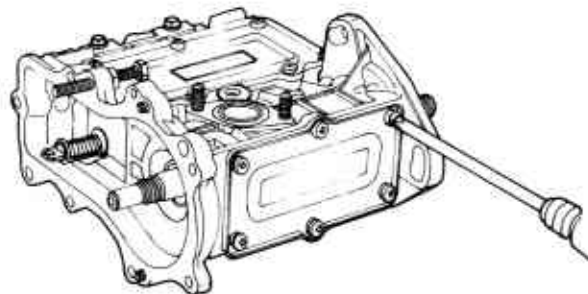

NOTE: Fit double nuts to turn the camshaft.

(18) Tighten delivery valve retainer.

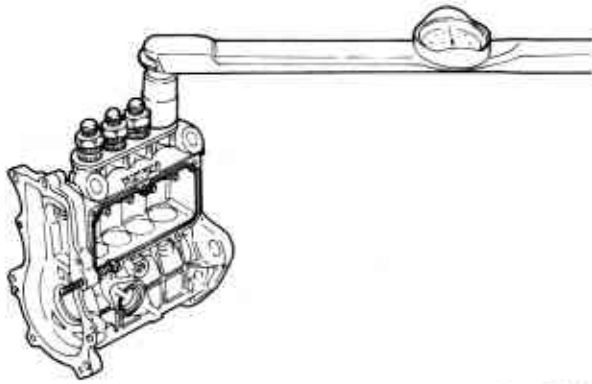

kg-m (ft-lb)

Tightening torque	3.5 ~ 4.0 (25.31 ~ 28.93)
-------------------	---------------------------

NOTE: 1. Tighten the retainer as far as possible by hand— if the bolt gets hard to turn part way, the packing or delivery valve are out of place. Remove, correct, and start tightening again.
2. Overtightening can result in malfunctioning of the rack.

(19) Fit the delivery retainer stop and tighten the stop bolt.

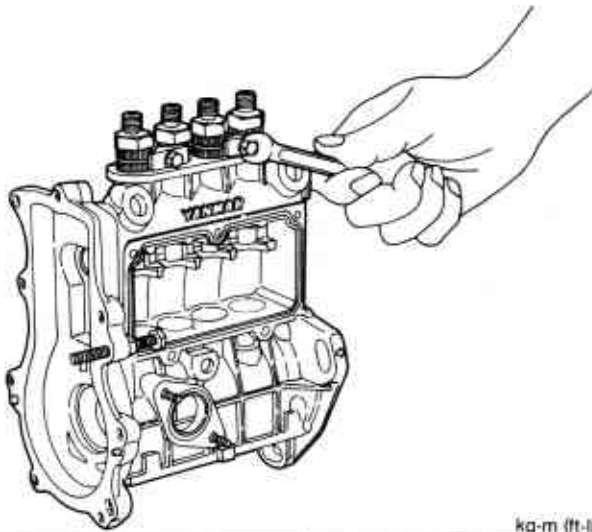

kg-m (ft-lb)

Tightening torque	0.3 (2.16)
-------------------	------------

NOTE: Overtightening can upset the delivery retainer and cause oil leakage.

(20) Mount the fuel feed pump

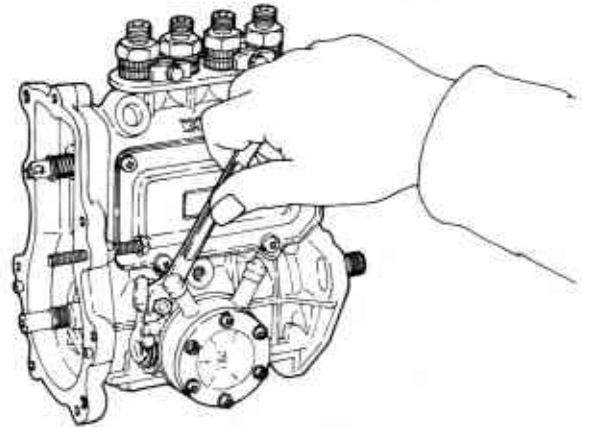

NOTE: See the item explaining reassembly of the fuel feed pump.

4. Adjustment of Fuel Injection Pump and Governor

Adjust the fuel injection pump after you have completed reassembly. The pump itself must be readjusted with a special pump tester when you have replaced major parts such as the plunger assembly, roller guide assembly, fuel camshaft, etc. Procure a pump tester like the one illustrated below.

4-1 Preparations

Prepare for adjustment of the fuel injection pump as follows:

- (1) Adjusting nozzle assembly and inspection of injection starting pressure.

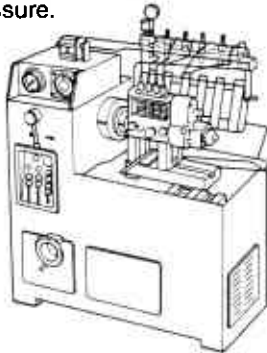

	kg/cm ² (lb/in. ²)
Adjusting nozzle type	YDN-12SD12
Injection starting pressure	165 ~ 175 (2346.85 ~ 2489.08)

- (2) Adjusting injection pipe.

	mm (in.)
Inner dia./outer dia. × length	2.0/6.0 × 600 (0.0787/0.2362 × 23.6220)
Minimum bending radius	25 (0.9842)

- (3) Mount the fuel injection pump on the pump tester platform.

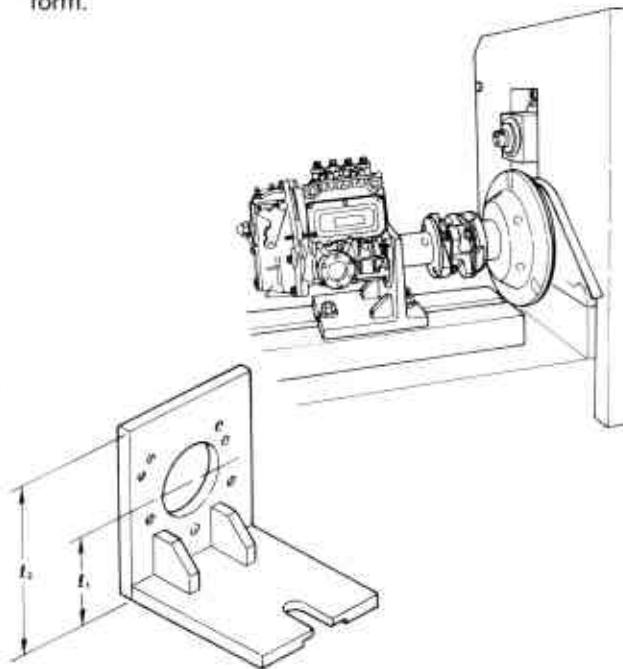

Tester used	l_1	l_2	Part code number
Yanmar	110 (4.3307)	150 (5.9055)	158090-51010
Robert Bosch	125 (4.9212)	165 (6.4960)	158090-51020

- (4) Remove the control rack blind cover and fit the rack indicator.

Next, turn the pinion from the side of the pump until the control rack is at the maximum drive side position, and set it to the rack indicator scale standard position. Then make sure that the control rack and rack indicator slide smoothly.

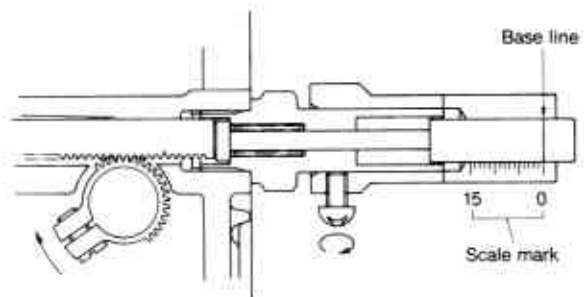
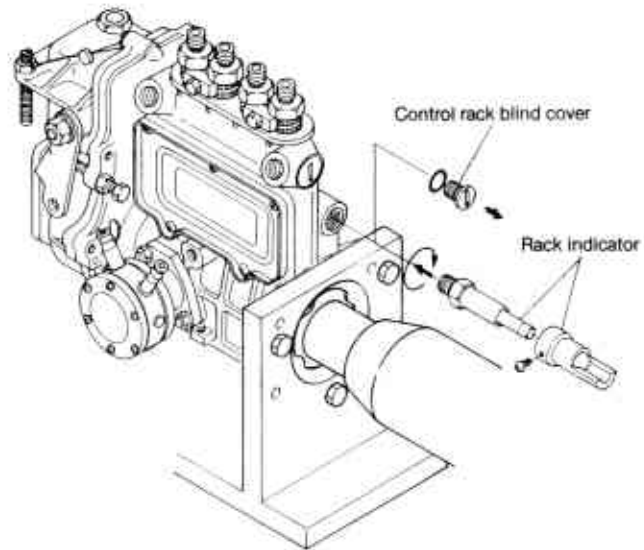
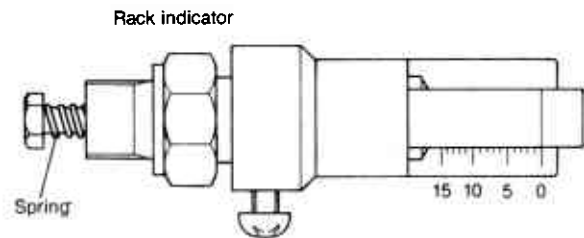

Part code number	158090-51500
------------------	--------------

(5) Check control rack stroke

Make sure the rack position is at 11.5 ~ 12.5mm (0.4527 ~ 0.4921in.) on the indicator scale when the governor control lever is set at the maximum operating position. If it is not at this value, change the link connecting the governor and control rack to adjust it.

NOTE: Links are available in 1mm (0.0394in.) increments.

(6) Remove the plug in the oil fill hole on the top of the governor case, and fill the pump with about 200cc of pump oil or engine oil.

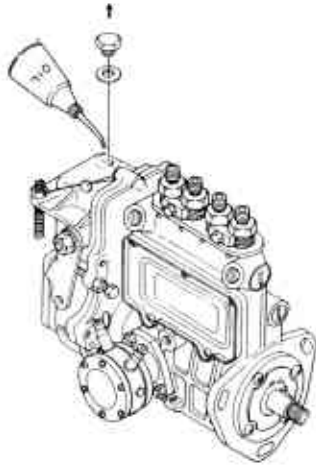

(7) Complete fuel oil piping and operate the pump tester to purge the line of air.

(8) Set the pressure of oil fed from pump tester to injection pump at 0.2 ~ 0.3kg/cm² (2.84 ~ 4.26 lb/in.²).

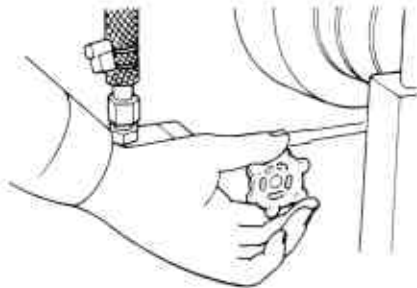

4-2 Adjustment of top clearance

Adjust the top clearance (clearance between top of plunger and top of barrel with cam at top dead point) of each cylinder plunger to bring it to the specified value by changing the thickness of the shims.

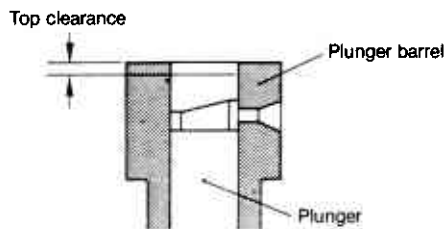

	mm (in.)
Top clearance	0.95-1.05 (0.0374-0.0413)
Pre-stroke	2.5 (0.0984)
Standard shim thickness	1.2 (0.0472)

Relation between top clearance, standard shim thickness and pre-stroke.

Adjusting shim thickness	mm (in.)
	1.0 (0.0394)
	1.2 (0.0472)
	1.3 (0.0512)
	1.4 (0.0551)
	1.5 (0.0591)
	1.6 (0.0630)
Part Code No.	129155-51600

(1) Place the top clearance gauge on a level surface and set the gauge to zero.

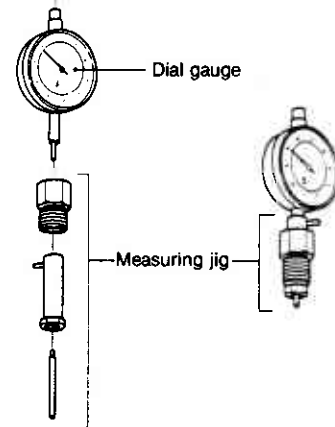
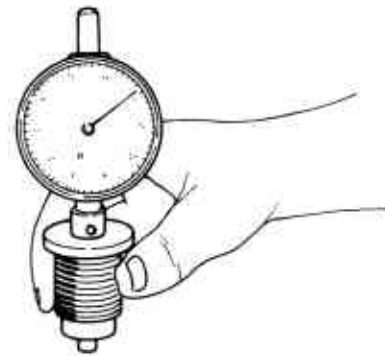

(2) Remove the injection pump delivery retainer, take out the delivery valve assembly, insert the top clearance gauge and tighten by hand.

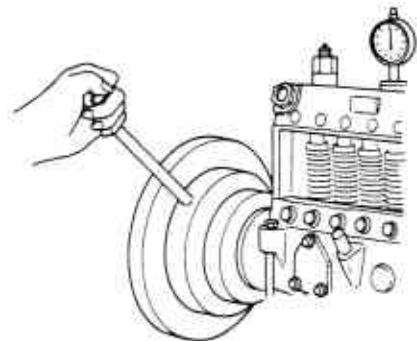

(3) Turn the camshaft, and bring cam to top dead point while watching gauge needle.

- (4) Read the gauge at this position, and adjust until the clearance is at the specified value by changing adjusting shims. Tighten the adjusting screw after completing adjustment.

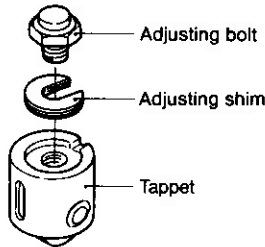

(Greater shim thickness decreases top clearance and smaller shim thickness increases top clearance).



NOTE: Adjust while watching gauge, and then tighten.

- (5) After adjustment is completed, insert the delivery valve assembly and tighten the delivery retainer.

	kg-m (ft-lb)
Delivery retainer tightening torque	3.5 ~ 4.0 (25.31 ~ 28.93)

Repeat the above procedure to adjust the top clearance of each cylinder.

4-3 Adjusting of injection timing

After adjusting the top clearance for all cylinders, check/adjust the injection timing.

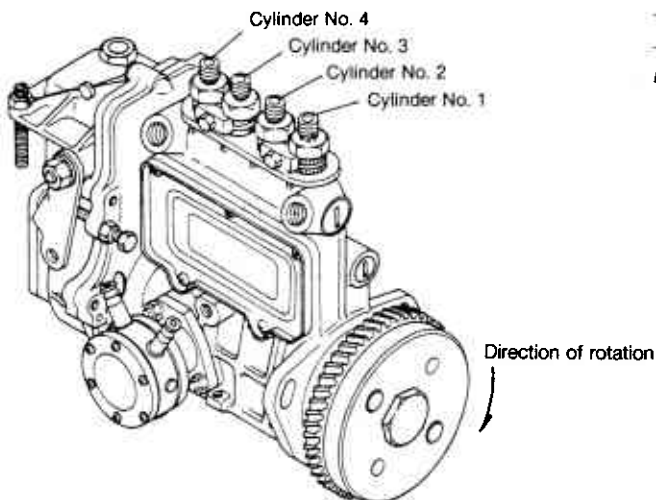

- (1) Set the governor control lever to the operating position and fix (bring plunger to the effective injection range), turn the camshaft clockwise, and check the injection starting time (FID) of cylinder No.1 (start of discharge of fuel from the delivery retainer).

Cylinder no.	Count from the drive side
Direction of rotation	Right looking from drive side

- (2) In the above state, set the tester needle to a position easy to read on the flywheel scale, and check the injection timing several times by reading the flywheel scale, according to the injection order.

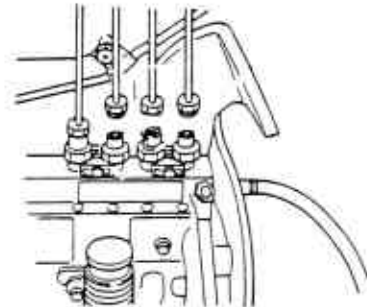

Injection order	1—3—4—2—1
Injection timing	90°
Allowable deviation	±30'

- (3) Readjust the top clearance of cylinders that are not within the allowable deviation (increasing adjusting shim thickness makes injection timing faster, and decreasing makes it slower).

The change in injection timing effected by adjusting shims is as follows:

Change in shim thickness	Change in injection timing	
	Cam angle	Crank angle
0.1mm (0.0039in.)	0.5°	1.0°

- (4) When you have readjusted top clearance, make sure it is within allowable values after completing adjustment.

Allowable top clearance	mm (in.) 0.3 (0.0118)
-------------------------	--------------------------

NOTE: 1. All cylinders must be readjusted if one shows less than the allowable value.

2. If the top clearance is less than the allowable value, the plunger will hit the delivery valve or the plunger flange will hit the plunger barrel.

4-4 Plunger pressure test

- (1) Mount the pressure gauge to the delivery retainer of the cylinder to be tested.

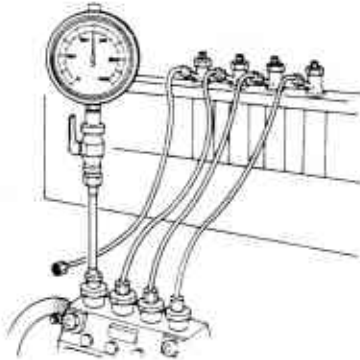

Max. pressure gauge reading	1000 kg/cm ² (14223 lb/in. ²)
Connecting screw dimensions	M12 × 1.5

- (2) Set the governor control lever to the stop position, operate the injection pump at about 200 rpm, and make sure that the pressure gauge reading is 500 kg/cm² (7110 lb/in.²) or more while lightly moving the control pinion gear towards full throttle (drive side) from the pump.

Replace the plunger if the pressure does not reach this value.

- (3) Immediately release the gear after pressure rises to stop injection.

At the same time, check to see that oil is not leaking from the delivery retainer or fuel injection piping, and that there is no extreme drop in pressure.

4-5 Delivery valve pressure test

- (1) Perform the plunger pressure test in the same way, bringing the pressure to about 120 kg/cm² (1706 lb/in.²), and then stopping injection.

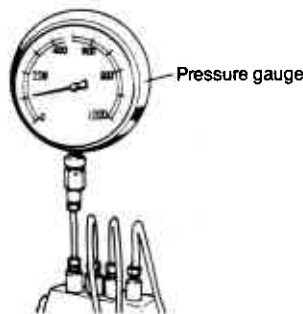

- (2) After pressure rises to the above value, measure the time it takes to drop from 100 ~ 90 kg/cm² (1422 ~ 2702 lb/in.²).

100 → 90 kg/cm ² (1422 ~ 1280 lb/in. ²)	5 seconds (to drop 10 kg/cm ² (142 lb/in. ²))
---	---

If the pressure drops faster than this, wash the delivery valve, and retest. Replace the delivery valve if the pressure continues to drop rapidly.

4-6 Adjusting injection volume (uniformity of each cylinder)

The injection volume is determined by the fuel injection pump rpm and rack position. Check and adjust to bring to specified value.

4-6.1 Measuring injection volume

- (1) Preparation

Set the pump rpm, rack position and measuring stroke to the specified value and measure:

Pump RPM	1800 rpm
Pump rotating direction	Right looking from drive side
Rack indicator scale reading	7mm (0.2756 in)

Remove the rack stop bolt behind the pump and screw in the rack fixing bolt to fix rack.

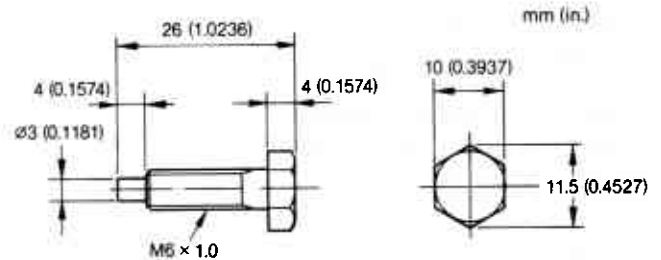
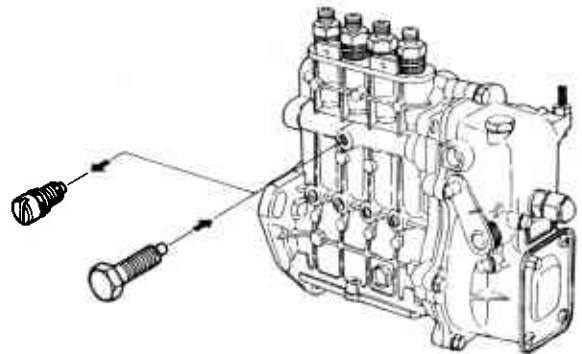

Part Code No.	158090-51510
---------------	--------------

- (2) Measuring injection volume

Measure the injection volume at the standard stroke, and adjust as follows if it is not within the specified value.

Measuring stroke	1,000 st
Specified injection volume at standard rack position	See injection pump service data
Nonuniformity of cylinders	± 3%

4-6.2 Adjustment of injection volume

Compare the injection volume collected in measuring cylinders for each cylinder, and adjust if necessary to obtain specified value.

- (1) Push the control rack all the way to the drive side, stop with rack fixing bolt, and loosen the pinion/sleeve fixing bolt 1/3 revolution.

- (2) Measure the injection volume while lowering the governor control lever to the idling position, and adjust the position of the control lever with the idling adjustment bolt to bring it to specified value.

Measuring stroke	1000 st
Idling injection volume	See injection pump service data

4-7.4 Check injection volume when starting

- (1) Make sure the control rack moves smoothly while gradually reducing idling rpm.
 (2) Next, fix the governor control lever at full load position with the pump at specified rpm (N_4). Make sure that control rack is at maximum rack position (11.05 ~ 12.05).

Measure the injection volume and check to make sure it is within the specified value.

Pump rpm (N_4)	200 rpm
Rack indicator scale	11.5~12.5mm(0.4527~0.4921 in.)
Measuring stroke	1000 st
Injection volume	See injection pump service data

Check injection stop

Drive the pump at rated rpm (N_1) and standard rack position (R_1) with governor control lever at full load position, operate the stop lever on the back of the governor case, and make sure that injection to all cylinders is stopped.

NOTE: Be sure to remove the rack fixing bolt when doing this.

5. Automatic Timer (Automatic Advancing Timer)

5-1 Timer construction

The faster the engine rpm, the larger the crank angle is during ignition delay. This results in a delay in ignition time and thus a decrease in engine output.

When an engine is used from low to high rpm, the injection timing must be changed according to engine rpm to maintain it at the optimum timing.

The automatic timer uses centrifugal force to automatically adjust injection timing.

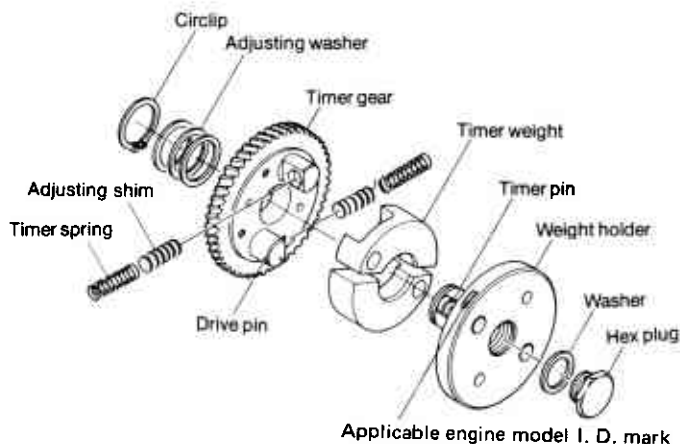

Automatic Timer Ass'y (Automatic Advancing Timer)	Old type	I. D. Mark	Applicable Engine Model & E/#		Advanced angle
		JH-AO	4JHE	E/# 00101 ~ 00574	7°
	JH-A1	4JHE	E/# 01000 and before	5.5°	
	JH-BO	4JH-TE	E/# 11000 and before	3.5°	
	JH-CO	4JH-HTE	E/# 21000 and before	2.5°	
	New type	TN-AO	4JHE	E/# 01001 and after	4°
		JH-CO	4JH-TE	E/# 11001 and after	2.5°
			4JH-HTE	E/# 21001 and after	
	4JH-DTE		E/# 30101 and after		

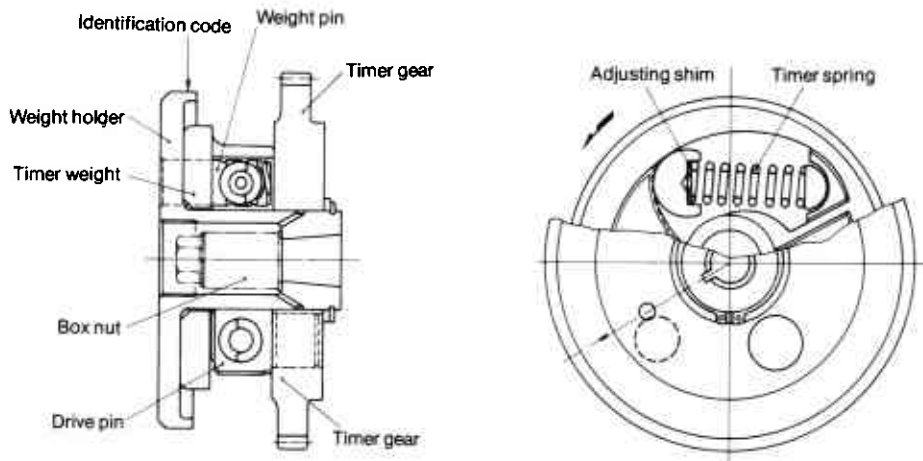

5-2 Functioning and characteristics of timer

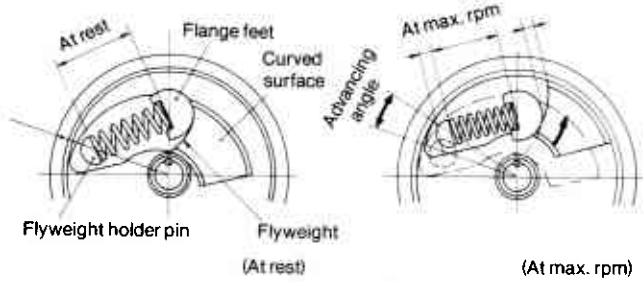

The spring is pressed against the center of the flyweight. As rpm increases, the centrifugal force of the two flyweights increases, compresses the timer spring, and the position of the weight holder and flange changes due to the movement of the curved surface of the weight, changing the injection timing. Accordingly, as the spring is compressed (according to the rise in rpm advancing the timing), the advancing angle remains proportional to rpm.

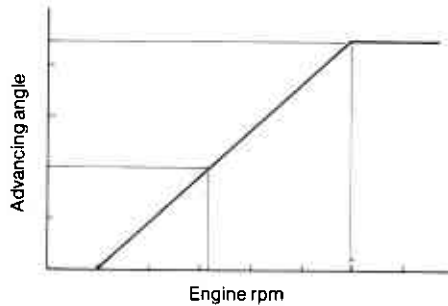

The advancing characteristics can be changed by changing the profile of the side of the weight and the spring constant of the spring.

5-3 Timer disassembly

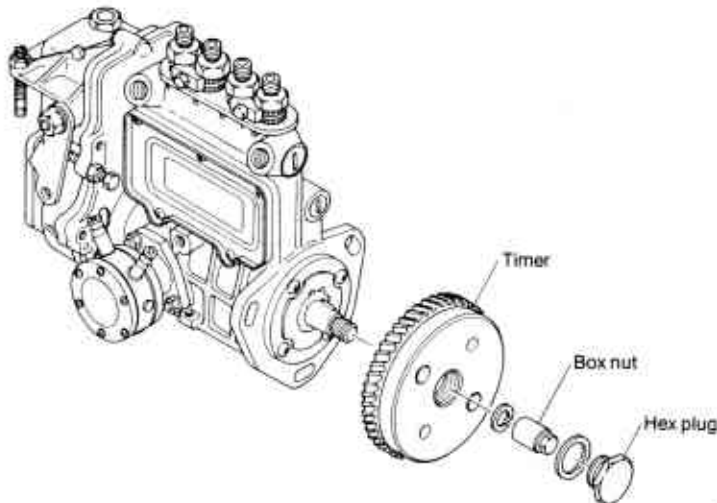

- (1) Remove the hex plugs from both ends of timer.
- (2) Use a box spanner to remove the cam shaft box nut.
- (3) Use a gear pulling tool to remove the timer assembly.
- (4) The spring, shim and weight can be removed when you take off the gear circlip and separate the timer and weight holder.

NOTE: As the advancing angle has been set at the factory, do not disassemble the timer unless necessary.

5-4 Timer inspection

- (1) Inspect the timer ring, and replace if there is excessive settling or corrosion.
- (2) Inspect the curved surface of the timer weight and the portion of drive pin it comes in contact with, and replace if wear is excessive or movement is not smooth.

NOTE: 1. Recheck advancing angle when replacing weight or spring, and readjust as necessary with adjusting shims.

2. If you change weight holders, measure the shaft side clearance, and adjust with washers.

Standard side clearance	0.02 ~ 0.10 (0.0007 ~ 0.0039)
-------------------------	----------------------------------

5-5 Timer reassembly

- (1) Mount the timer assembly on the fuel injection pump camshaft, and tighten the box nut with a box spanner.

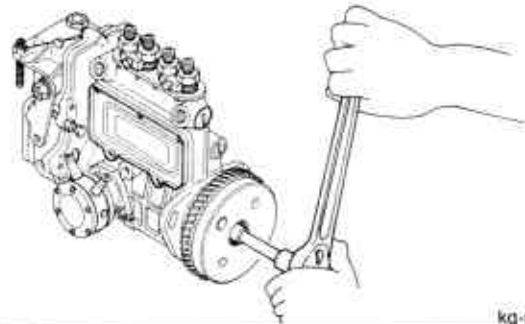

Tightening torque	8 ~ 7 (43.3 ~ 50.6)
-------------------	---------------------

NOTE: The box nut is tightened by turning it right looking from the drive side.

- (2) Apply grease around the box nut, and tighten the hex plug.

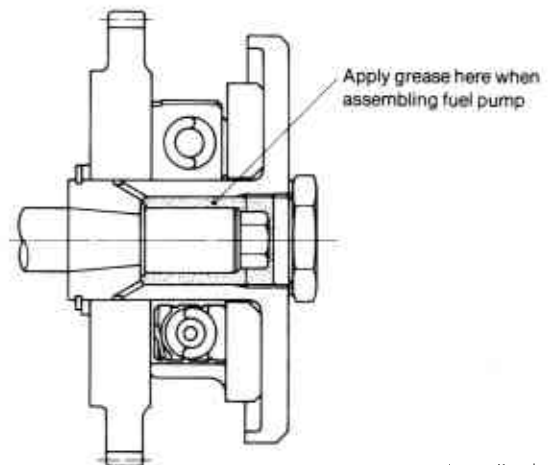

Tightening torque	0.8 ~ 1.20 (1.30 ~ 8.67)
-------------------	--------------------------

6. Fuel Feed Pump

The fuel feed pump pumps fuel from the fuel tank, passes it through the fuel filter element, and supplies it to the fuel injection pump.

The fuel feed pump is mounted on the side of this engine and is driven by the (eccentric) cam of the fuel pump camshaft. It is provided with a manual priming lever so that fuel can be supplied when the engine is stopped.

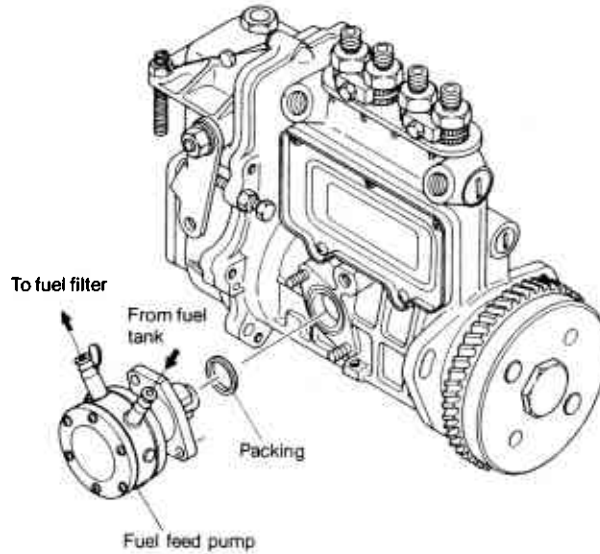

6-1 Construction of fuel feed pump

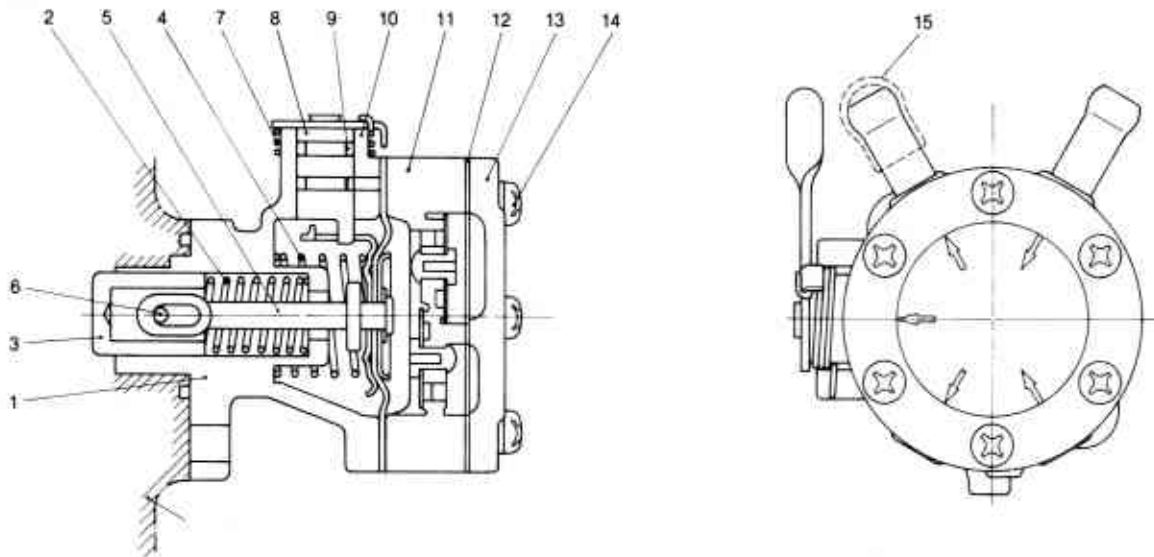

- | | | |
|-----------------------|------------------------|-----------------------|
| 1. Bottom body | 6. Pin | 11. Top body assembly |
| 2. Piston spring | 7. Lever return spring | 12. Packing |
| 3. Piston | 8. Lever assembly | 13. Cover |
| 4. Diaphragm spring | 9. O-ring | 14. Small screw |
| 5. Diaphragm assembly | 10. Stop pin | 15. Cap |

6-2 Fuel feed pump specifications

Head	1m (3.28 ft)
Discharge volume	230 cc/min (14.03 in. ³ /min) at 1500 cam rpm, discharge pressure of 0.2 kg/cm ² (2.84 lb/in. ²)
Closed off pressure	0.3 kg/cm ² (4.26 lb/in. ²) or more (at 400 cam rpm)

6-3 Disassembly and reassembly of fuel feed pump

6-3.1 Disassembly

- (1) Remove the fuel feed pump mounting nut, and take the fuel feed pump off the fuel injection pump.
- (2) Clean the fuel feed pump assembly with fuel oil.
- (3) After checking the orientation of the arrow on the cover, make match marks on the upper body and cover, remove the small screw, and disassemble the cover, upper body and lower body.

6-3.2 Reassembly

- (1) Clean all parts with fuel oil, inspect, and replace any defective parts.
- (2) Replace any packings on parts that have been disassembled.
- (3) Make sure that the intake valve and discharge valve on upper body are mounted in the proper direction, and that you don't forget the valve packing.
- (4) Assemble the diaphragm into the body, making sure the diaphragm mounting holes are lined up (do not force).
- (5) Align the match marks on the upper body of the pump and cover, and tighten the small screws evenly.

	kg-cm (ft-lb)
Tightening torque	15 ~ 25 (1.08 ~ 1.80)

6-4 Fuel feed pump inspection

- (1) Place the fuel feed pump in kerosene, cover the discharge port with your finger, move the priming lever and check for air bubbles (Repair or replace any part which emits air bubbles).

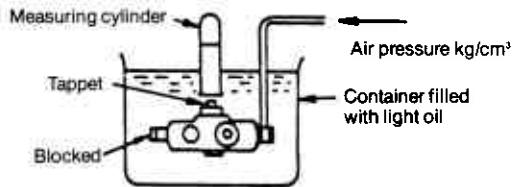

- (2) Attach a vinyl hose to the fuel feed pump intake, keep the pump at the specified depth from the fuel oil surface, move the priming lever by hand and check for sudden spurts of fuel oil from the discharge port. If oil is not spurting out, inspect the diaphragm and diaphragm spring and repair/replace as necessary.
- (3) Diaphragm inspection
Parts of the diaphragm that are repeatedly burned will become thinner or deteriorate over a long period of time. Check diaphragm and replace if necessary.

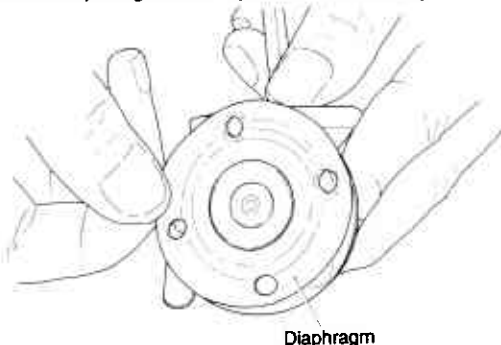

(4) Valve contact/mounting

Clean the valve seat and valve with air to remove any foreign matter.

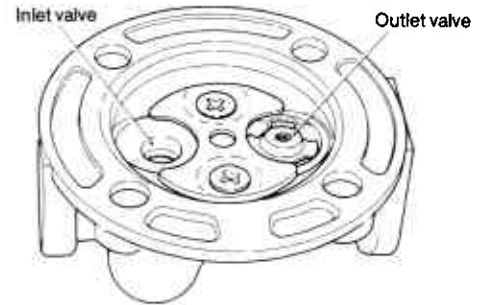

- (5) Inspect the diaphragm spring and piston spring for settling and the piston for wear, and replace as necessary.

NOTE: Replace parts as an assembly.

7. Fuel Injection Nozzle

When fuel oil pumped by the fuel injection pump reaches the injection nozzle, it pushes up the nozzle valve (held down by spring), and is injected into the combustion chamber at high pressure.

The fuel is atomized by the nozzle to mix uniformly with the air in the combustion chamber. How well the fuel is mixed with high temperature air directly affects combustion efficiency, engine performance and fuel economy.

Accordingly, the fuel injection nozzles must be kept in top condition to maintain performance and operating efficiency.

7-1 Functioning of fuel injection nozzle

Fuel from the fuel injection pump passes through the oil port in the nozzle holder, and enters the nozzle body reservoir.

When oil reaches the specified pressure, it pushes up the nozzle valve (held by the nozzle spring), and is injected through the small hole on the tip of the nozzle body.

The nozzle valve is automatically pushed down by the nozzle spring and closed after fuel is injected.

Oil that leaks from between the nozzle valve and nozzle body goes from the hole on top of the nozzle spring through the oil leakage fitting and back into the fuel tank.

Adjustment of injection starting pressure is effected with the adjusting shims.

(1) Hole type fuel injection nozzle

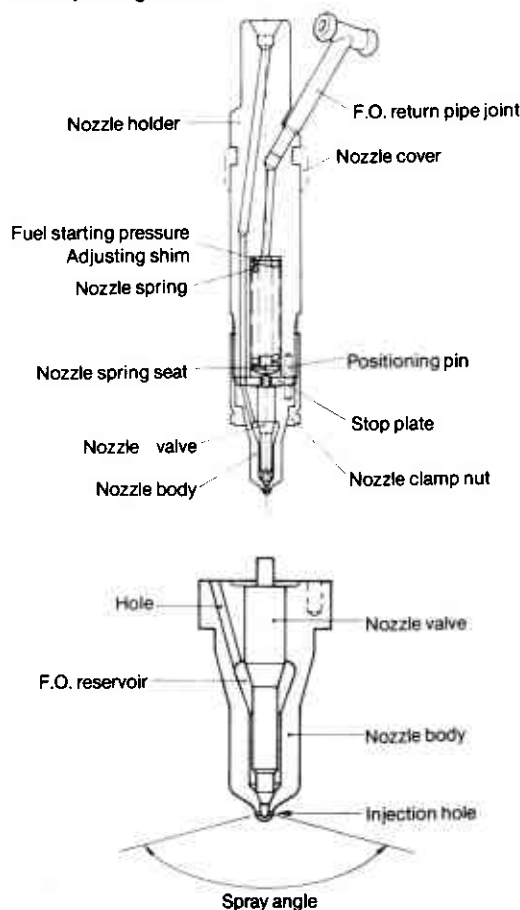
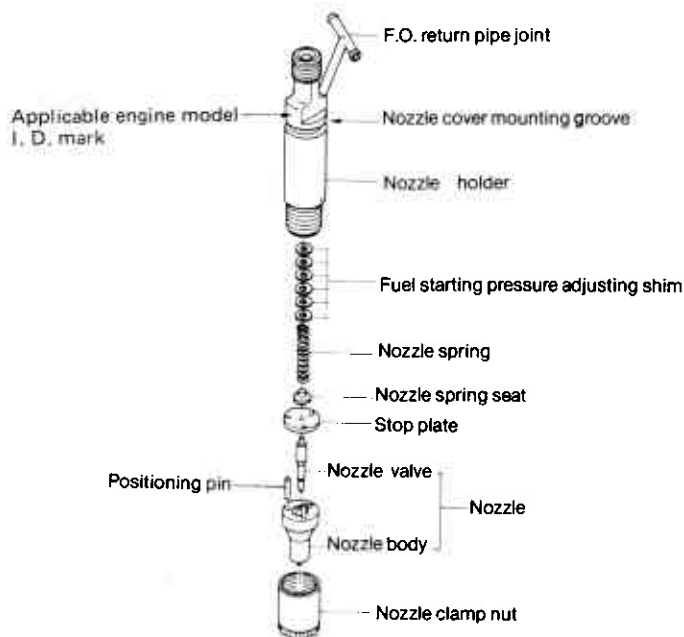

Fuel Injection Nozzle Ass'y I. D. Mark	A	E	B	D	F	G		
Spray angle	150°	155°	150°	145°	155°	140°		
Nozzle opening pressure	195 ~ 205 kg/cm ² (2,773 ~ 2,915 lb/in. ²)							
No. of injection hole x dia	4 x 0.24mm (0.0094 in.)		4 x 0.28mm (0.0110 in.)	5 x 0.26mm (0.0102 in.)	4 x 0.24mm (0.0094 in.)	5 x 0.25mm (0.0098 in.)		
Nozzle I. D. mark	150P244J0	155P244J1	150P284J0	145P265J1	155P265J1	140P255J2		
Applicable engine model	4JHE		4JH-TE	4JH-HTE	4JHE	4JH-TE	4JH-HTE	4JH-DTE
Applicable engine No.	#00101 ~ #00574	#00575 ~ 01000	#00101 ~ 11000	#20101 ~ 21000	#01001 and after	#11001 and after	#21001 and after	#30101 and after

(3) Nozzle body identification number

The type of nozzle can be determined from the number inscribed on the outside of the nozzle body.

1) Hole type fuel injection nozzles

Sample

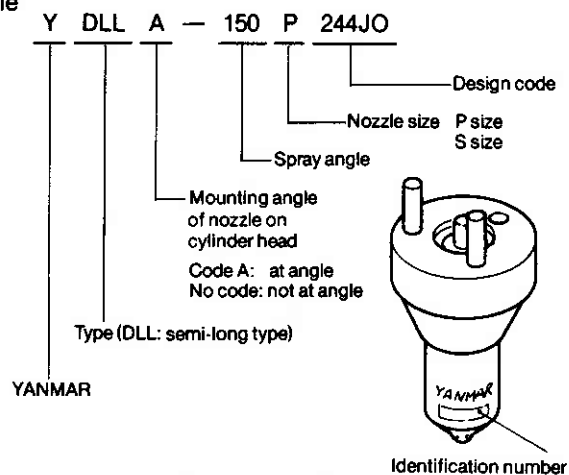

7-3 Fuel injection nozzle disassembly

NOTE: 1. Disassemble fuel injection nozzle in a clean area as for fuel injection pump.

2. When disassembling more than one fuel injection nozzle, keep the parts for each injection nozzle separate for each cylinder (i.e. the nozzle for cylinder 1 must be remounted in cylinder 1).

(1) When removing the injection nozzle from the cylinder head, remove the high pressure fuel pipe, fuel leakage pipe, etc., the injection nozzle retainer nut, and then the fuel injection nozzle.

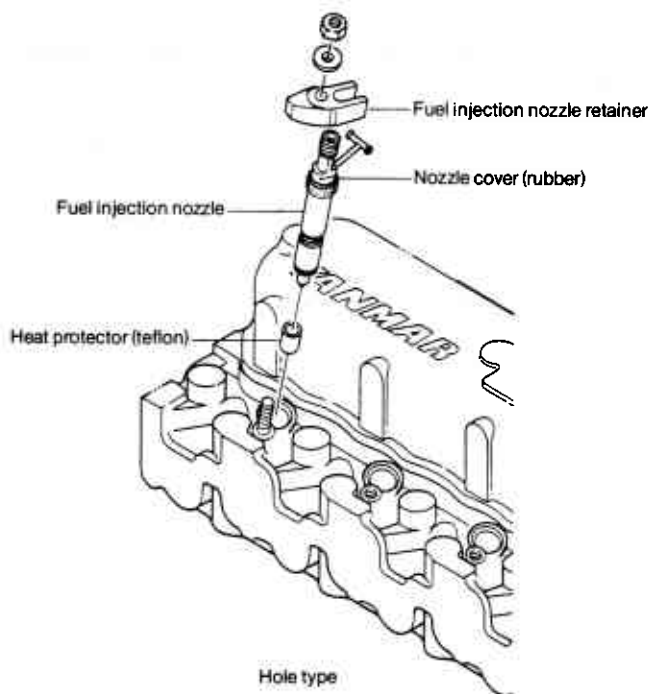

(2) Put the nozzle in a vise

NOTE: Use the special nozzle holder for the hole type injection nozzle so that the high pressure mounting threads are not damaged.

(3) Remove the nozzle nut

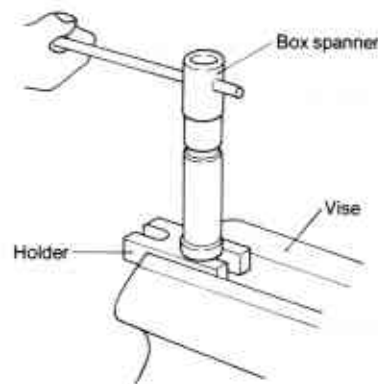

NOTE: Use a special box spanner for the hole type (the thickness of the two nozzle nuts is 15mm (0.5906in.)).

(4) Remove the inner parts

NOTE: Be careful not to loosen the spring seat, adjusting shims or other small parts.

7-4 Fuel injection nozzle inspection

7-4.1 Washing

(1) Make sure to use new diesel oil to wash the fuel injection nozzle parts.
(2) Wash the nozzle in clean diesel oil with the nozzle cleaning kit.



- 1) Diesel Kiki nozzle cleaning kit:
Type NP-8486B No. 5789-001
- 2) Anzen Jidosha Co., Ltd. nozzle cleaning kit:
Type NCK-001

(3) Clean off the carbon on the outside of the nozzle body with a brass brush.

(4) Clean the nozzle seat with cleaning spray.

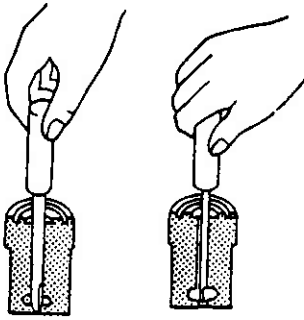

(5) Clean off the carbon on the tip of nozzle with a piece of wood.

(6) Clean hole type nozzles with a nozzle cleaning needle.

Nozzle cleaning needle (piano wire)
0.2mm dia. wire, 22mm long × 5 wires



Part code no.	28210-000010
---------------	--------------

7-4. 2 Nozzle inspection

(1) Inspect for scratches/wear

Inspect oil seals for abnormal scratches or wear and replace nozzle if the nozzle sliding surface or seat are scratched or abnormally worn.

(2) Check nozzle sliding

Wash the nozzle and nozzle body in clean diesel oil, and make sure that when the nozzle is pulled out about half way from the body, it slides down by itself when released.

Rotate the nozzle a little; replace nozzle/nozzle body as a set if there are some places where it does not slide smoothly.

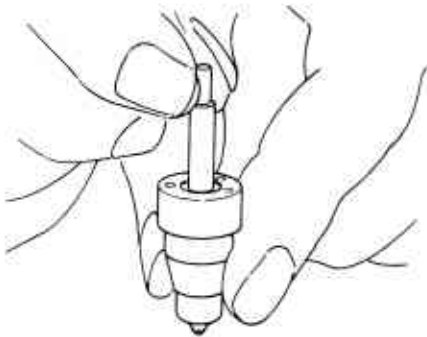

(3) Inspecting stop plate (inter-piece)

Check for scratches/wear in seals on both ends, check for abnormal wear on the surface where it comes in contact with the nozzle; replace if stop plate is excessively worn.

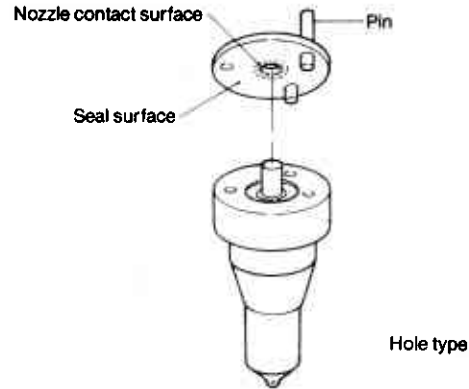

	mm (in.)
Nozzle contact surface wear limit	0.1 (0.0039)

(4) Inspecting nozzle spring

Replace the nozzle spring if it is extremely bent, or the surface is scratched or rusted.

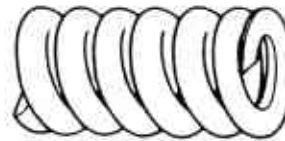

(5) Nozzle holder

Check oil seal surface for scratches/wear; replace if wear is excessive.

7-5 Fuel injection nozzle reassembly

The fuel injection nozzle is reassembled in the opposite order to disassembly.

(1) Insert the adjusting shims, nozzle spring and nozzle spring seat in the nozzle holder, mount the stop plate with the pin, insert the nozzle body/nozzle set and tighten the nut.

(2) Use the special holder when tightening the nut for the hole type nozzle as in disassembly.

	kg-m (ft-lb)
Nozzle nut tightening torque	
Hole type nozzle	4 ~ 4.5 (28.9 ~ 32.5)

7-6 Adjusting fuel injection nozzle

7-6. 1 Adjusting opening pressure

Mount the fuel injection nozzle on the nozzle tester and use the handle to measure injection starting pressure. If it is not at specified pressure, use the adjusting shims to increase/decrease pressure (both hole and pintle types).

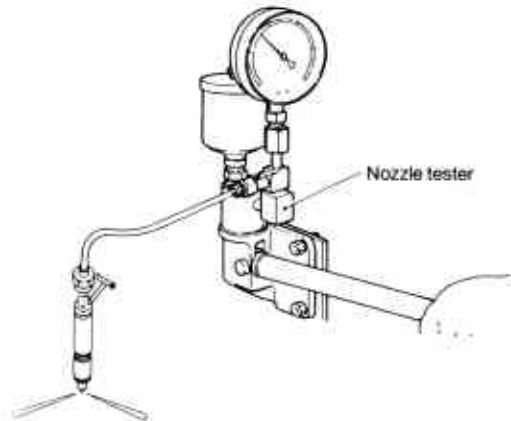

Injection starting pressure

kg/cm² (lb/in.²)

Injection starting pressure	195 ~ 205 (2773 ~ 2915)
-----------------------------	-------------------------

7-6. 2 Injection test

After adjusting the nozzle to the specified starting pressure, check the fuel spray condition and seat oil tightness.

(1) Check seat oil tightness

After two or three injections, gradually increase the pressure up to 20 kg/cm² (284 lb/in.²) before reading the starting pressure, maintain the pressure for 5 seconds, and make sure that no oil is dripping from the tip of the nozzle.

Test the injection with a nozzle tester; retighten and test again if there is excessive oil leakage from the overflow coupling.

Replace the nozzle as a set if oil leakage is still excessive.

(2) Injection spray condition

Operate the nozzle tester lever once to twice a second and check for abnormal injection.

1) Hole type nozzles

Replace hole type nozzles that do not satisfy the following conditions:

- Proper spray angle (θ)
- Correct injection angle (α)
- Complete atomization of fuel
- Prompt starting/stopping of injection

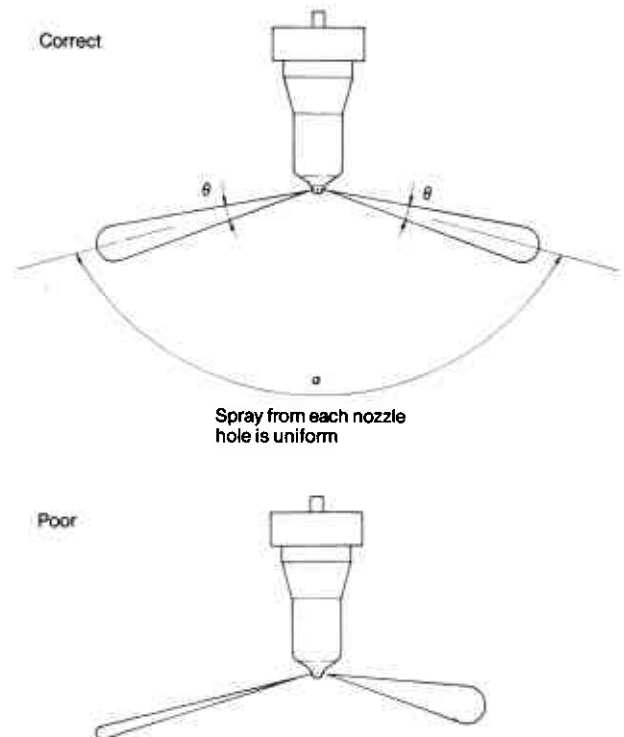

- Excessive difference in spray angle (θ)
- Excessive difference in injection angle (α)
- Incomplete atomization
- Sluggish starting/stopping of injection

8. Troubleshooting

1. Troubleshooting of fuel injection pump

Complete repair means not only replacing defective parts, but finding and eliminating the cause of the trouble as well. The cause of the trouble may not necessarily be in the pump itself, but may be in the engine or the fuel system. If the pump is removed prematurely, the true cause of the trouble may never be known. Before removing the pump from the engine, at least go through the basic check points given here.

Basic check points

- Check for breaks or oil leaks throughout the fuel system, from the fuel tank to the nozzle.
- Check the injection timings for all cylinders. Are they correctly adjusted? Are they too fast or too slow?
- Check the nozzle spray.
- Check the fuel delivery. Is it in good condition? Loosen the fuel pipe connection at the injection pump inlet, and test operate the fuel feed pump.

2. Major faults and troubleshooting

Fault		Cause	Remedy
1. Engine won't start.	Fuel not delivered to injection pump.	(1) No fuel in the fuel tank. (2) Fuel tank cock is closed. (3) Fuel pipe system is clogged. (4) Fuel filter element is clogged. (5) Air is sucked into the fuel due to defective connections in the piping from the fuel tank to the fuel pump. (6) Defective valve contact of feed pump (7) Piston spring of feed pump is broken. (8) Inter-spindle or tappets of feed pump are stuck.	Resupply Open Clean Disassemble and clean, or replace element Repair Repair or replace. Replace Repair or replace
	Fuel delivered to injection pump.	(1) Defective connection of control lever and accel. rod of injection pump. (2) Plunger is worn out or stuck. (3) Delivery valve is stuck. (4) Control rack doesn't move. (5) Injection pump coupling is damaged, or the key is broken.	Repair or adjust Repair or replace Repair or replace Repair or replace Replace
	Nozzle doesn't work.	(1) Nozzle valve doesn't open or close normally. (2) Nozzle seat is defective. (3) Case nut is loose. (4) Injection nozzle starting pressure is too low. (5) Nozzle spring is broken. (6) Fuel oil filter is clogged. (7) Excessive oil leaks from the nozzle sliding area.	Repair or replace Repair or replace Inspect and tighten Adjust Replace Repair or replace Replace the nozzle assembly
	Injection timing is defective.	(1) Injection timing is retarded due to failure of the coupling. (2) Camshaft is excessively worn. (3) Roller guide incorrectly adjusted or excessively worn. (4) Plunger is excessively worn.	Adjust Replace camshaft Adjust or replace Replace plunger assembly
2. Engine starts, but immediately stops.		(1) Fuel pipe is clogged. (2) Fuel filter is clogged. (3) Improper air-tightness of the fuel pipe connection, or pipe is broken and air is being sucked in. (4) Insufficient fuel delivery from the feed pump.	Clean Disassemble and clean, or replace the element. Replace packing; repair pipe Repair or replace

Fault		Cause	Remedy
3. Engine's output is insufficient.	Defective injection timing, and other failures.	(1) Knocking sounds caused by improper (too fast) injection timing. (2) Engine overheats or emits large amount of smoke due to improper (too slow) injection timing. (3) Insufficient fuel delivery from feed pump.	Inspect and adjust Inspect and adjust Repair or replace
	Nozzle movements is defective	(1) Case nut loose. (2) Defective injection nozzle performance. (3) Nozzle spring is broken. (4) Excessive oil leaks from nozzle.	Inspect and retighten Repair or replace nozzle Replace Replace nozzle assembly
	Injection pump is defective.	(1) Max. delivery limit bolt is screwed in too far. (2) Plunger is worn. (3) Injection amount is not uniform. (4) Injection timings are not even. (5) The 1st and 2nd levers of the governor and the control rack of the injection pump are improperly lined up. (6) Delivery stopper is loose. (7) Delivery packing is defective. (8) Delivery valve seat is defective. (9) Delivery spring is broken.	Adjust Replace Adjust Adjust Repair Inspect and retighten Replace packing Repair or replace Replace
4. Idling is rough.	(1) Movement of control rack is defective. 1) Stiff plunger movement or sticking. 2) Rack and pinion fitting is defective. 3) Movement of governor is improper. 4) Delivery stopper is too tight. (2) Uneven injection volume. (3) Injection timing is defective. (4) Plunger is worn and fuel injection adjustment is difficult. (5) Governor spring is too weak. (6) Feed pump can't feed oil at low speeds. (7) Fuel supply is insufficient at low speeds due to clogging of fuel filter.	Repair or replace Repair Repair Inspect and adjust Adjust Adjust Replace Replace Repair or replace Disassemble and clean, or replace element	
5. Engine runs at high speeds, but cuts out at low speeds.	(1) The wire or rod of the accel. is caught. (2) Control rack is caught and can't be moved.	Inspect and repair Inspect and repair	
6. Engine doesn't reach max. rpm.	(1) Governor spring is broken or excessively worn. (2) Injection performance of nozzle is poor.	Replace Repair or replace	
7. Loud knocking.	(1) Injection timing is too fast or too slow. (2) Injection from nozzle is improper. Fuel drips after each injection. (3) Injection nozzle starting pressure is too high. (4) Uneven injection. (5) Engine overheats, or insufficient compression.	Adjust Adjust Adjust Adjust Repair	
8. Engine exhausts too much smoke.	When exhaust smoke is black:	(1) Injection timing is too fast. (2) Air volume intake is insufficient. (3) The amount of injection is uneven. (4) Injection from nozzle is improper.	Adjust Inspect and repair Adjust Repair or replace
	When exhaust smoke is white:	(1) Injection timing is too slow. (2) Water is mixed in fuel. (3) Shortage of lube oil in the engine. (4) Engine is over-cooled.	Adjust Inspect fuel system, and clean Repair Inspect



9. Fuel Injection Pump Service Data



July 18 '85

Adjustment	Item	Engine model		4JHE		4JH-TE		4JH-HTE		4JH-DTE	
		Part No.	I.D. mark	729470 - 51300	729472 - 51300	729474 - 51300	729476 - 51300	729478 - 51300	8364		
	Assemble cord			B300		B303		B306		B364	
	Adjustment specs.			Engine specs.	Calibration specs.	Engine specs.	Calibration specs.	Engine specs.	Calibration specs.	Engine specs.	Calibration specs.
4-1(1)	Nozzle type	I.D. mark	150P244J0/*155P244J1/*155P244J2	DN-12SD12	DN-12SD12	150P284J0/*140P255J2	DN-12SD12	145P265J1/*140P255J2	DN-12SD12	140P255J2	DN-12SD12
	Injection starting pressure	kg/cm ² (lb./in. ²)	195 ~ 205 (2,773 ~ 2,915)	165 ~ 175 (2,346 ~ 2,489)	165 ~ 175 (2,346 ~ 2,489)	195 ~ 205 (2,773 ~ 2,915)	165 ~ 175 (2,346 ~ 2,489)	195 ~ 205 (2,773 ~ 2,915)	165 ~ 175 (2,346 ~ 2,489)	195 ~ 205 (2,773 ~ 2,915)	165 ~ 175 (2,346 ~ 2,489)
4-1(2)	Fuel injection pipe	mm φ / I.D. φ x L	φ 6 / φ 1.8 x 400 (0.2362/0.078 x 15.748)	φ 6 / φ 2 x 600 (0.2362/0.0787 x 23.622)	φ 6 / φ 2 x 600 (0.2362/0.0787 x 23.622)	φ 6 / φ 1.8 x 400 (0.2362/0.078 x 15.748)	φ 6 / φ 2 x 600 (0.2362/0.0787 x 23.622)	φ 6 / φ 2 x 400 (0.2362/0.0787 x 15.748)	φ 6 / φ 2 x 600 (0.2362/0.0787 x 23.622)	φ 6 / φ 2 x 400 (0.2362/0.0787 x 15.748)	φ 6 / φ 2 x 600 (0.2362/0.0787 x 23.622)
4-2	Top clearance /Prestroke	mm (in)	0.95 ~ 1.05/2.5 (0.0374 ~ 0.0413/0.0984)		0.95 ~ 1.05/2.5 (0.0374 ~ 0.0413/0.0984)		0.95 ~ 1.05/2.5 (0.0374 ~ 0.0413/0.0984)		0.95 ~ 1.05/2.5 (0.0374 ~ 0.0413/0.0984)		0.95 ~ 1.05/2.5 (0.0374 ~ 0.0413/0.0984)
4-7-1	Pump rpm: N1	rpm	1,800	1,800	1,800	1,800	1,800	1,800	1,800	1,800	1,800
	Rack position: R1	mm(in.)	7 (0.2756)	7 (0.2756)	7 (0.2756)	7 (0.2756)	7 (0.2756)	7 (0.2756)	7 (0.2756)	7 (0.2756)	7 (0.2756)
	Measuring stroke	St	1,000	1,000	1,000	1,000	1,000	1,000	1,000	1,000	1,000
	Injection volume	cc	25	26.5	**27.5	31	32	**34	33	34	**36.5
	Nonuniformity	%	± 3	± 3	± 3	± 3	± 3	± 3	± 3	± 3	± 3
4-7-2	Pump rpm: N2	rpm	1,950	1,950	1,950	1,950	1,950	1,950	1,950	1,950	1,950
	Rack position: R2	mm(in.)									
4-7-3	Pump rpm: N3	rpm	325	325	325	325	325	325	325	325	325
	Measuring stroke	St	1,000	1,000	1,000	1,000	1,000	1,000	1,000	1,000	1,000
	Injection volume	cc	7 ~ 8	8 ~ 9	8 ~ 9	9 ~ 10	10 ~ 11	10 ~ 11	9 ~ 10	9 ~ 10	10 ~ 11
	Nonuniformity	%	± 10	± 10	± 10	± 10	± 10	± 10	± 10	± 10	± 10
4-7-4	Pump rpm: N4	rpm	200	200	200	200	200	200	200	200	200
	Rack position	mm(in.)	11.5 ~ 12.5 (0.4527 ~ 0.4921)	11.5 ~ 12.5 (0.4527 ~ 0.4921)	11.5 ~ 12.5 (0.4527 ~ 0.4921)	11.5 ~ 12.5 (0.4527 ~ 0.4921)	11.5 ~ 12.5 (0.4527 ~ 0.4921)	11.5 ~ 12.5 (0.4527 ~ 0.4921)	11.5 ~ 12.5 (0.4527 ~ 0.4921)	11.5 ~ 12.5 (0.4527 ~ 0.4921)	11.5 ~ 12.5 (0.4527 ~ 0.4921)
	Measuring stroke	St	1,000	1,000	1,000	1,000	1,000	1,000	1,000	1,000	1,000
	Injection volume	cc	60~70	55~65	**65~75	60~70	55~65	**65~75	60~70	55~65	**65~75

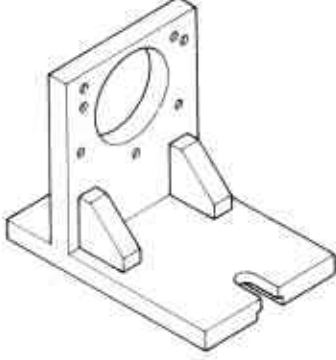
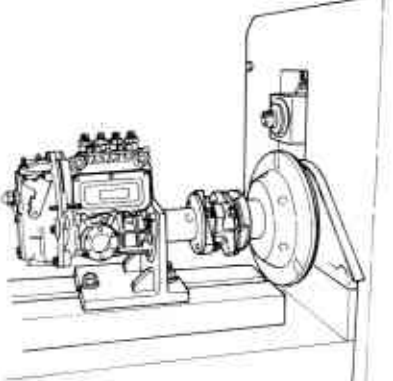
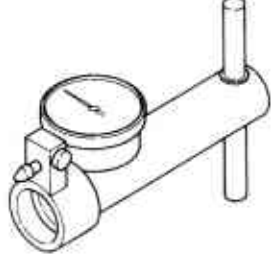
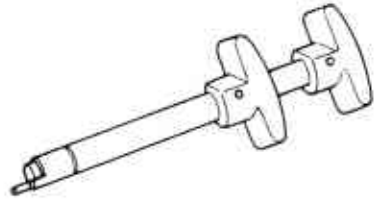
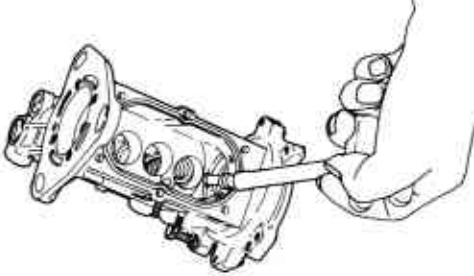
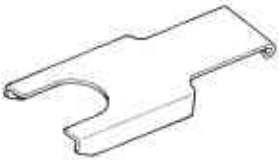
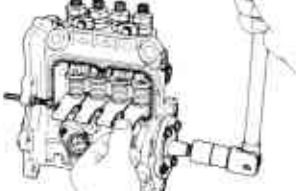
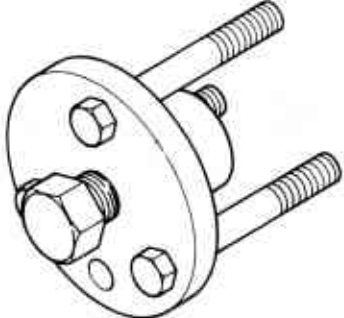
NOTE 1 : * Applicable engine number : # 00575 and after (Engine model 4JHE)
NOTE 2 : ** Applicable engine model and engine number : 4JH-TE # 11001 and after
4JH-HTE # 21001 and after
4JHE # 01001 and after

10. Tools

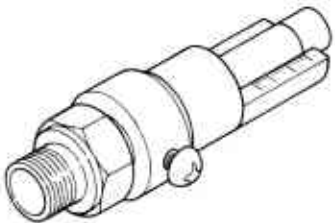
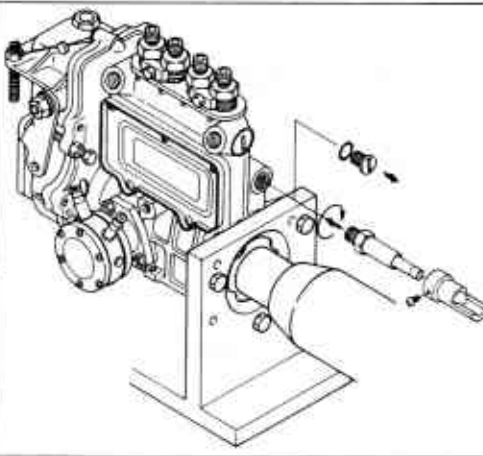
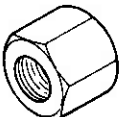
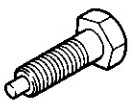
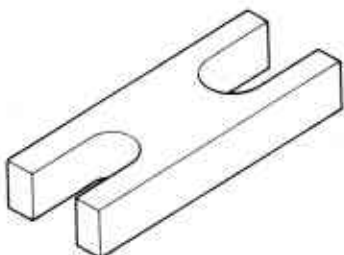
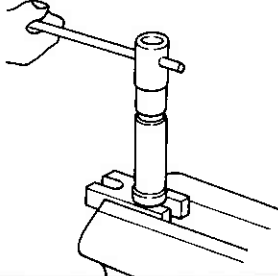
Name of tool	Shape and size	Application
<p>Pump mounting scale for Yanmar tester 158090-51010 for Bosch (tester) 158090-51020</p>		
<p>Measuring device (cam backlash) 158090-51050</p>		
<p>Plunger insert 158090-51100</p>		
<p>Tappet holder 158090-51200</p>		
<p>Weight extractor 158090-51400</p>		

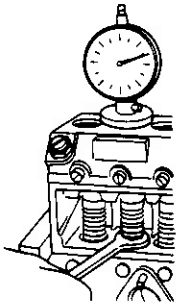
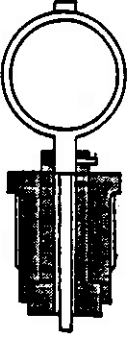
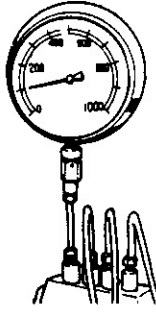
Name of tool	Shape and size	Application
Rack indicator 158090-51500		
Rack lock screw 158090-51010		
Dummy nut 158090-51520		
Nozzle plate 158090-51700		
Plunger gauge 121820-92540		
Top clearance gauge 158090-51300		
Timer extraction tool		

11. Fuel Filter

The fuel filter is installed between the fuel feed pump and fuel injection pump, and removes dirt/foreign matter from the fuel pumped from the fuel tank.

The fuel filter element must be changed periodically. The fuel pumped by the fuel feed pump goes around the element, is fed through the pores in the filter and discharged from the center of the cover. Dirt and foreign matter in the fuel is deposited in the element.

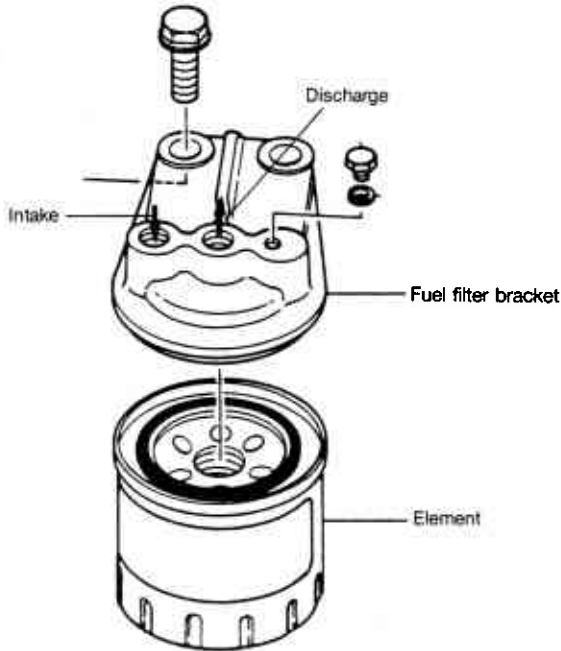

11-1 Fuel filter specifications

Filtering method	filter paper
Filtering area	840cm ² (130.20in. ²)
Maximum flow	0.25 l/min (15.25 in. ³ /min)
Pressure loss	100mm (3.9370in.) Hg or less
Max. dia. of unfiltered particle	5μ

11-2 Fuel filter inspection

The fuel strainer must be cleaned occasionally. If there is water or foreign matter in the strainer bowl, disassemble the strainer and wash with clean fuel oil to completely remove foreign matter. Replace the element every 300 hours of operation.

Replace the filter prior to this if the filter is very dirty, deformed or damaged.

Element changes	every 300 hours
Element part code number	129470-55700

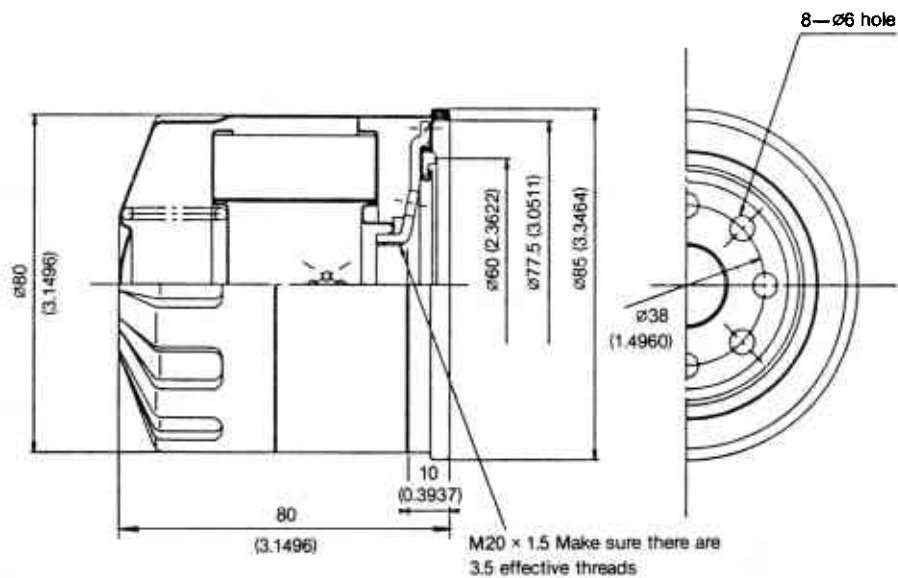

12. Fuel Tank

A triangular 30 liter fuel tank with a 2000mm (78.7402in.) rubber fuel hose to fit all models is available as an option. A fuel return connection is provided on top of the tank to which a rubber hose can be connected to return fuel from the fuel nozzles.

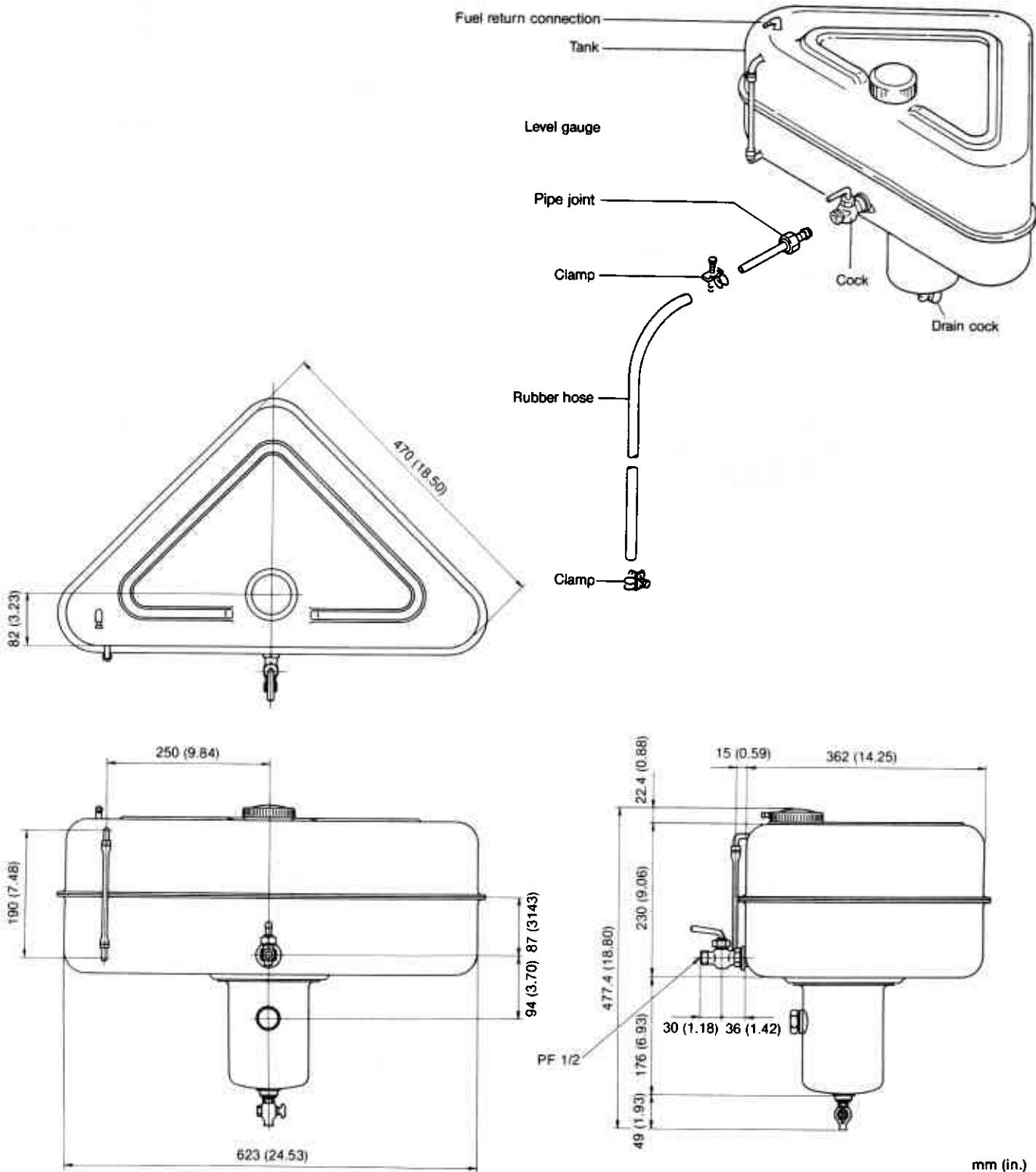

mm (in.)

13. Design Change of Fuel Piping Line

To facility easy servicing, following design modifications will be made on the marine diesel engine model 4JH-series. Through the change of fuel piping line, air-bleeding will be done more easily.

13-1 Modification of fuel piping line.

OLD FUEL PIPING LINE

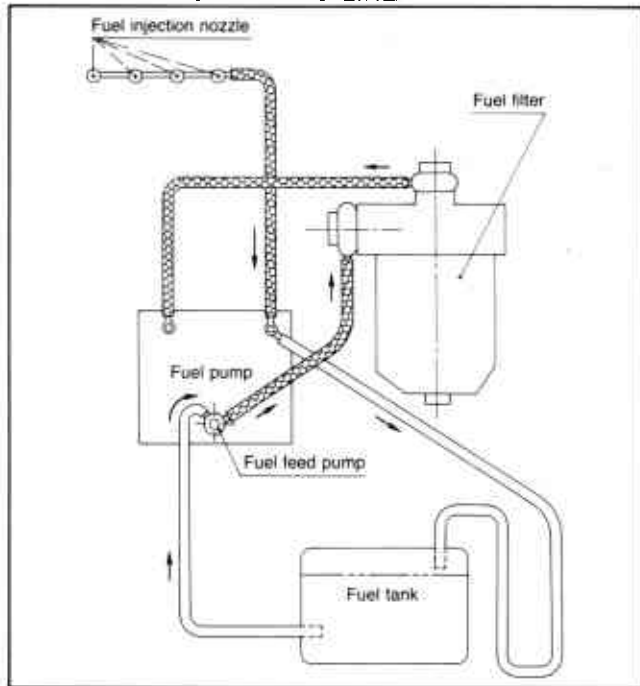

NEW FUEL PIPING LINE

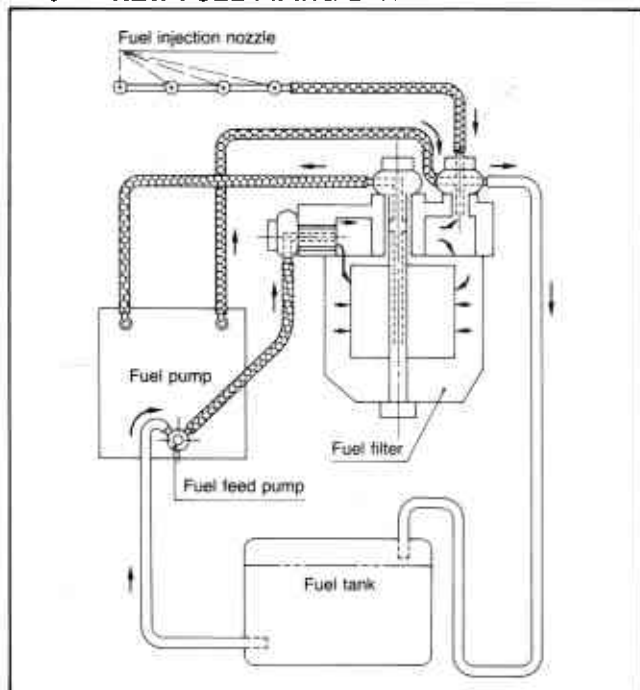

13-2 Applicable engine models and serial numbers.

Engine Model	Serial Number	Plant Production
4JH(B)E	#01179 and thereafter	From Dec., 1985
4JH-T(B)E	#11201 and thereafter	
4JH-HT(B)E	#21226 and thereafter	
4JH-DT(B)E	#30312 and thereafter	

NOTE: Air-bleeding of the following engines with the modified fuel piping require the equivalent procedure as in the engine with the former fuel piping.

Engine Model	Serial Number
4JH(B)E	#01109 - 01178
4JH-T(B)E	#11143 - 11200
4JH-HT(B)E	#21180 - 21225
4JH-DT(B)E	#30256 - 30311