

CHAPTER 5

LUBRICATION SYSTEM

<u>1</u>	<u>Lubrication System</u>	<u>5-1</u>
<u>2</u>	<u>Lube Oil Pump</u>	<u>5-3</u>
<u>3</u>	<u>Lube Oil Filter</u>	<u>5-6</u>
<u>4</u>	<u>Oil Pressure Control Valve</u>	<u>5-8</u>
<u>5</u>	<u>Lube Oil Cooler</u>	<u>5-9</u>
<u>6</u>	<u>Piston Cooling Nozzle</u>	<u>5-11</u>
<u>7</u>	<u>Rotary Waste Oil Pump (Optional)</u>	<u>5-12</u>

1. Lubrication System

The lube oil in the oil pan is pumped up through the intake filter and intake piping by the lube oil pump, through the holes in the cylinder body and on to the discharge filter.

The lube oil which flows from the holes in the cylinder body through the bracket to the oil element is filtered and sent to the oil cooler. It returns from the oil cooler to the bracket, the pressure is regulated, and it is fed back to main gallery in cylinder body.

The lube oil which flows in the main gallery goes to the crankshaft journal, lubricates the crank pin from the crankshaft journal, and a portion of the oil is fed to the camshaft bearings.

Oil is sent from the gear case camshaft bearings through

the holes in the cylinder body and cylinder head to the valve arm shaft to lubricate the valve arm and valves.

Oil is also sent from the main gallery to the piston cooling nozzle to cool the piston surface, and is sent through the intermediate gear bearing (oil) holes to lubricate the intermediate gear bearings and respective gears.

Lube oil for the fuel injection pump is sent by pipe from the main gallery to the fuel injection pump.

Part of the lube oil is sent from the oil cooler discharge to the supercharger in engines fitted with one, and is then piped back from the supercharger to the oil pan.

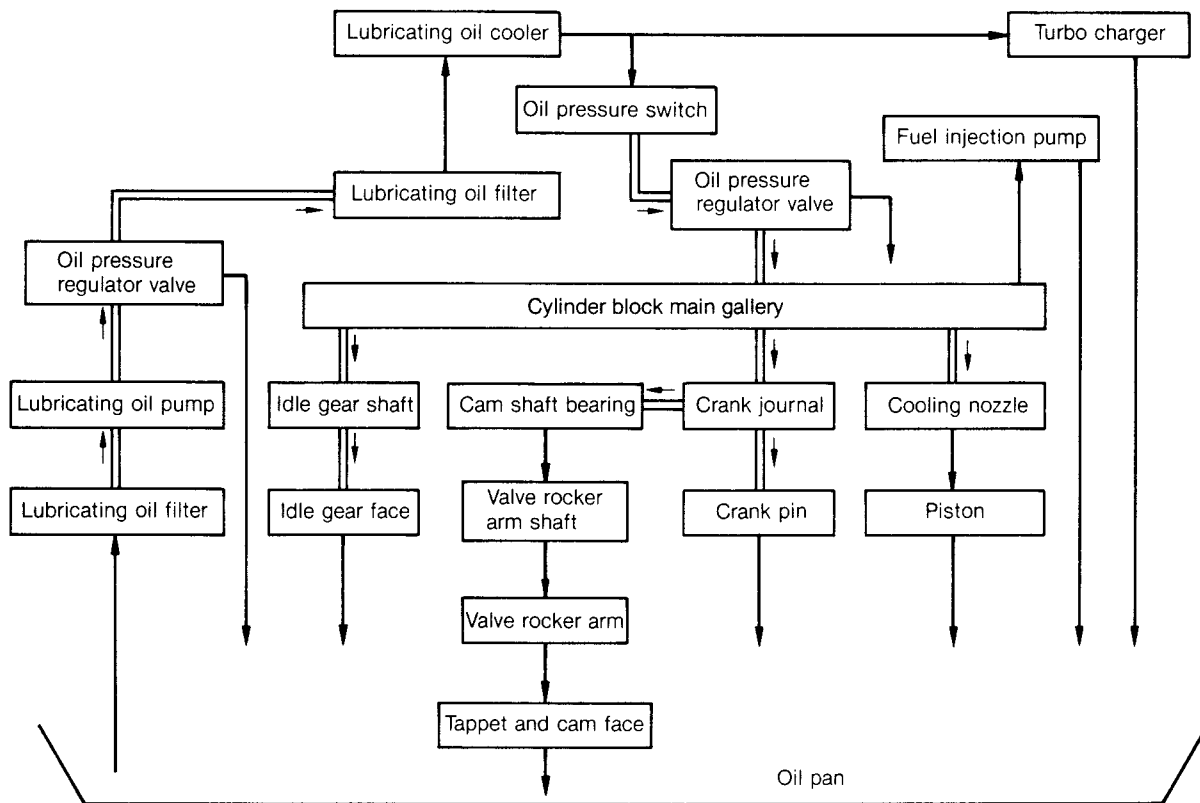

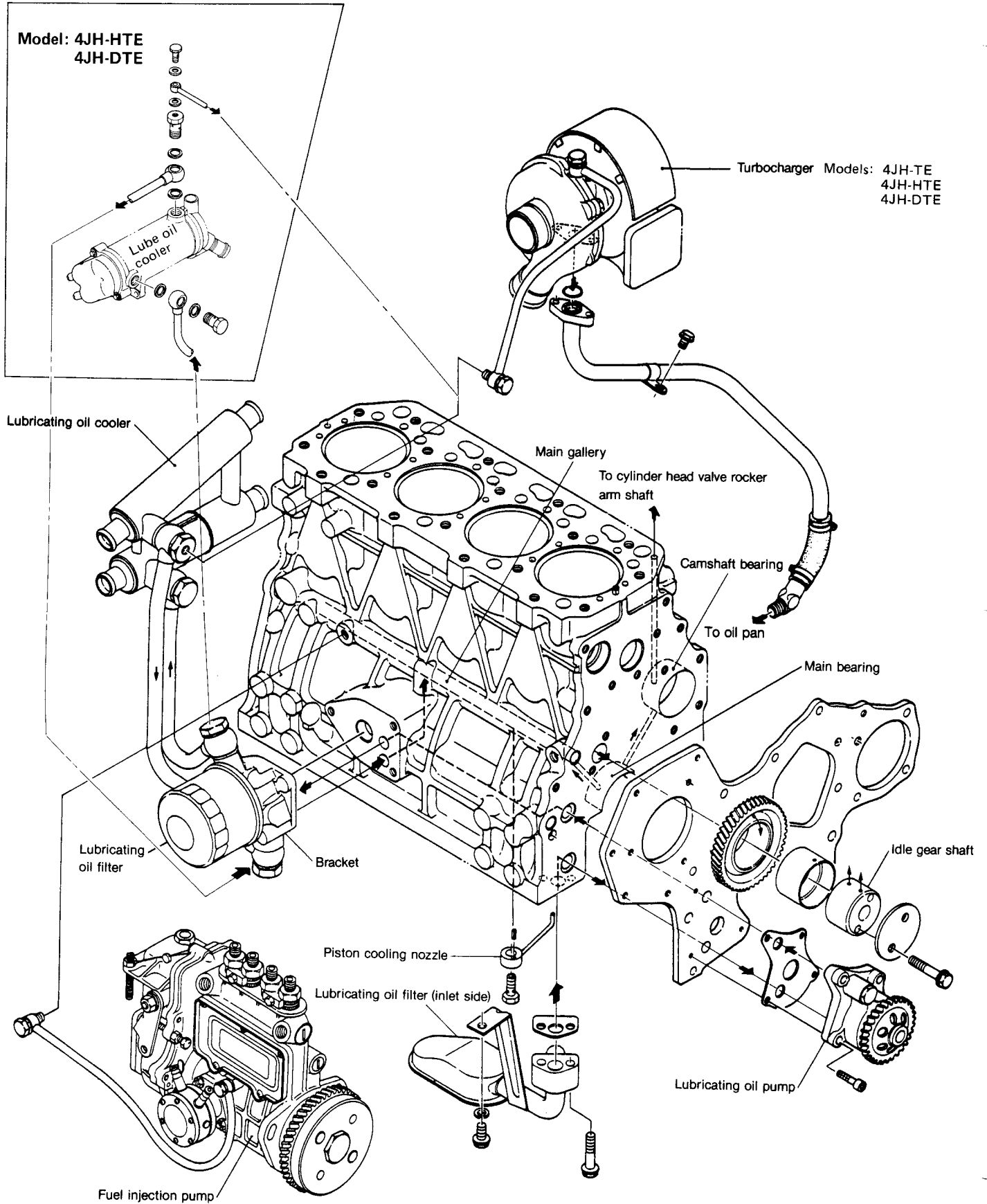

2. Lube Oil Pump

2-1 Lube oil pump construction

The trochoid type lube oil pump is mounted on the gear case side engine plate, and the rotor shaft gear is driven by the crankshaft gear.

The lube oil flows from the intake filter mounted on the bottom of the cylinder body through the holes in the cylinder body and engine plate, and out from the holes in the engine plate and cylinder body to the discharge filter.

The lube oil pump is fitted with a pressure regulating valve which maintains the discharge pressure at 3kg/cm².

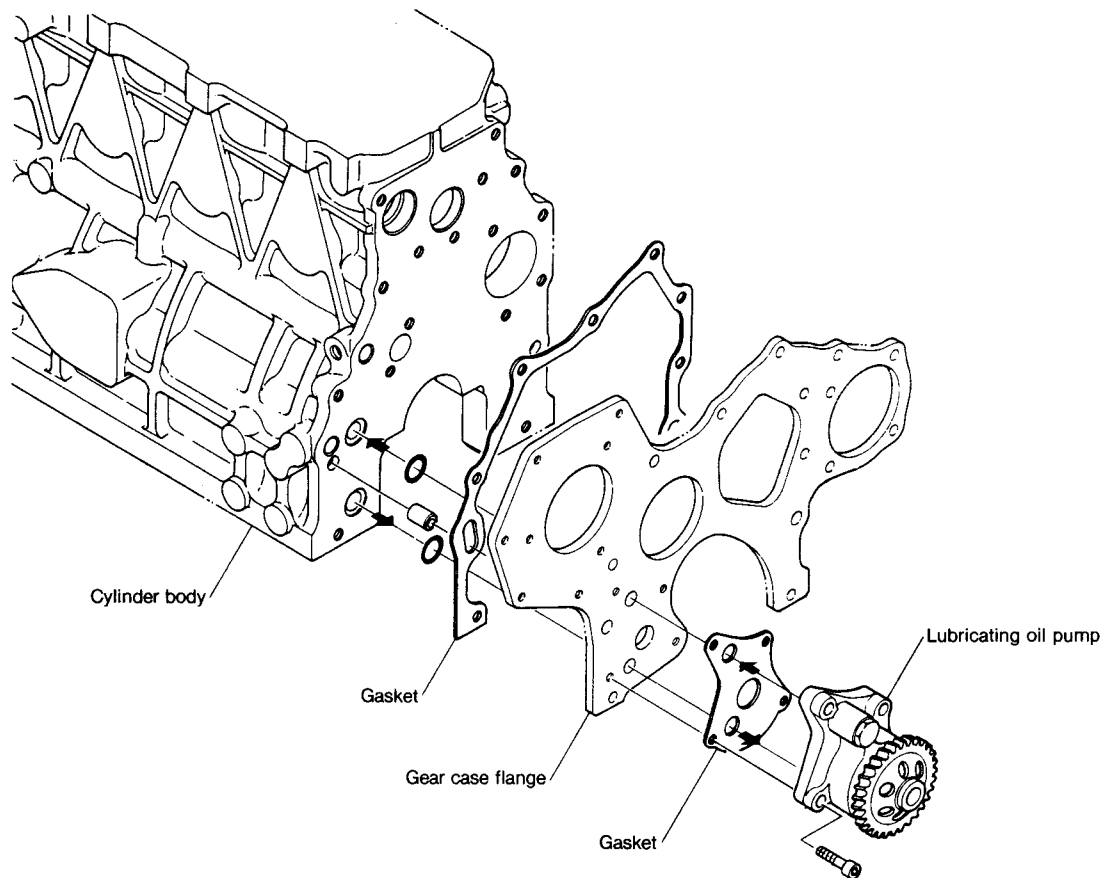
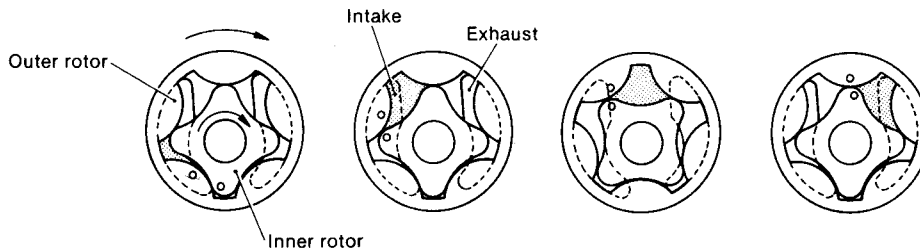

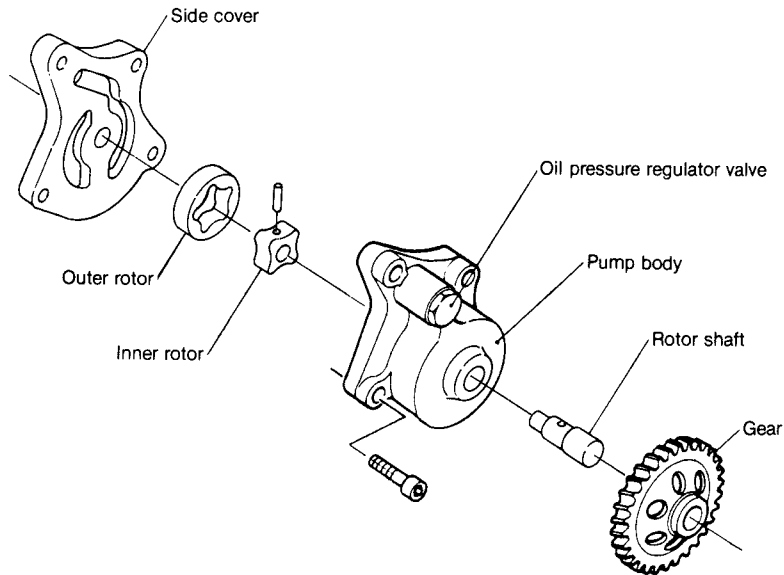
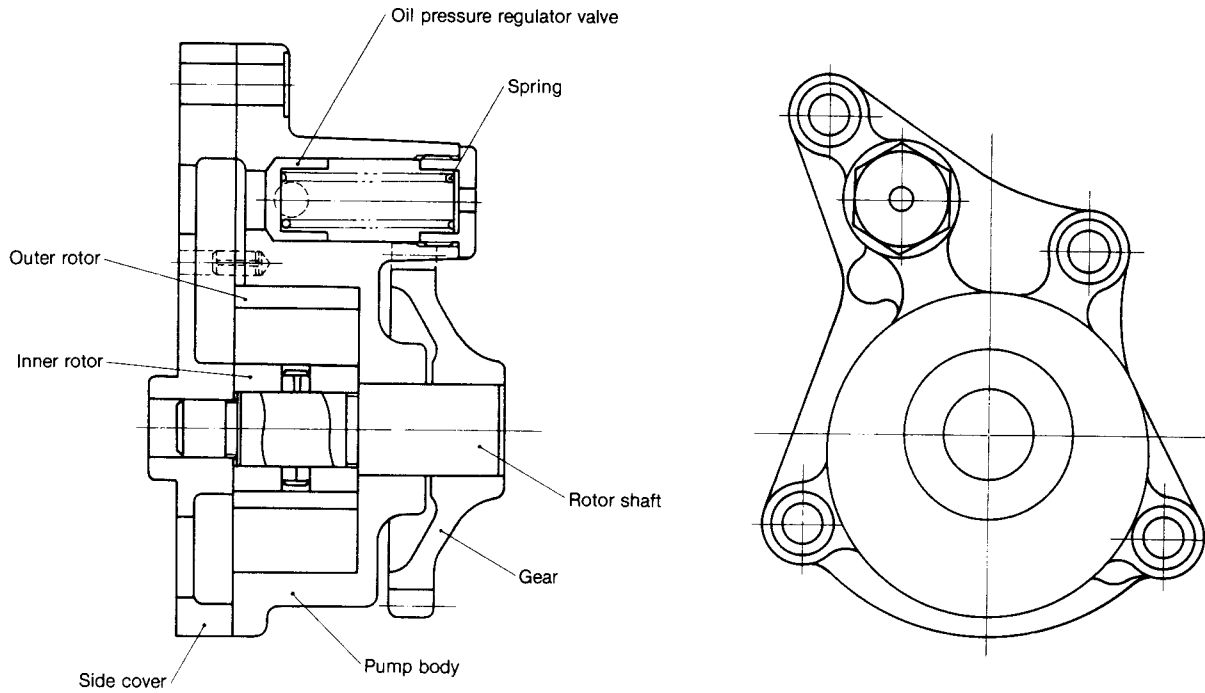

2-2 Specifications of lube oil pump

Engine speed	3600 rpm
Gear ratio (crank gear/pump gear)	28/29
Pump speed	3477 rpm
Discharge volume	36 l/min (2196 in. ³ /min)
Discharge pressure	3 kg/cm ² (42.66 lb/in. ²)

2-3 Lube oil pump disassembly

- (1) Remove the lube oil pump assembly from the engine plate.
- (2) The lube oil pump cover may be disassembled, but do not disassemble the rotor, rotor shaft or drive gear. The oil pressure regulating valve plug is coated with adhesive and screwed in, so it cannot be disassembled. These parts cannot be reused after disassembly. Replace if necessary as an assembly.

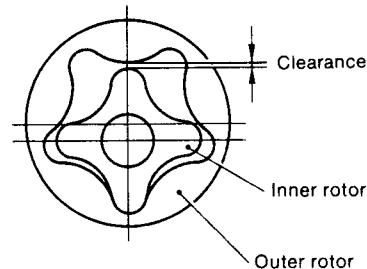

2-4 Lube oil pump inspection

- (1) Clearance between outer rotor and pump body
Insert a feeler gauge between the outer rotor and pump body to measure the clearance, and replace if it exceeds the limit.

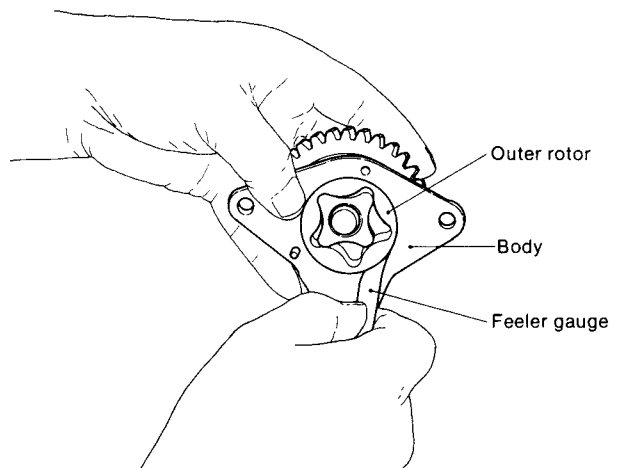

	mm (in.)	
	Standard	Wear limit
Outer rotor and pump body clearance	0.100 ~ 0.170 (0.0039 ~ 0.0066)	0.25 (0.0098)

- (2) Clearance between outer rotor and inner rotor
To measure clearance, insert a feeler gauge between the top of the inner rotor tooth and the top of the outer rotor tooth, and replace if it exceeds the limit.

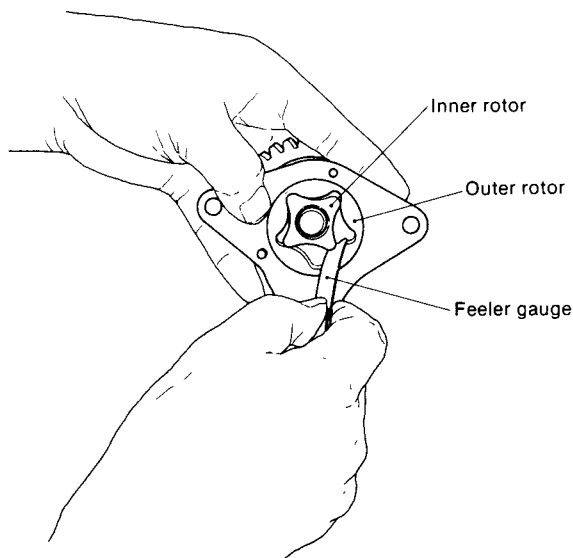

	mm (in.)	
	Standard	Wear limit
Outer rotor and inner rotor clearance	0.050 ~ 0.105 (0.0019 ~ 0.0041)	0.15 (0.0059)

- (3) Clearance between pump body and inner rotor side of outer rotor
Place a straight-edge against the end of the pump body and insert a feeler gauge between the straight-edge and the rotor to measure side clearance. Replace the assembly if the clearance exceeds the limit.

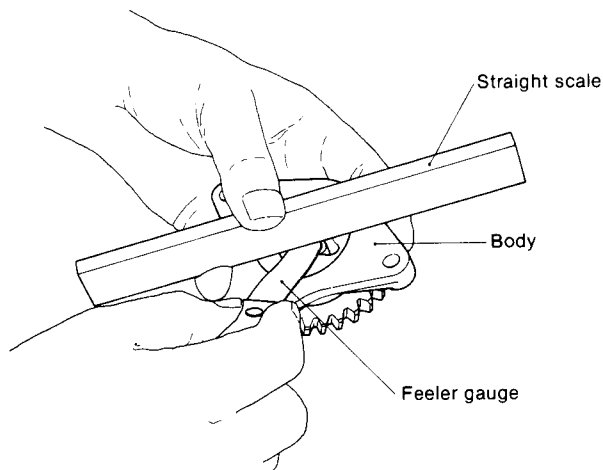

	mm (in.)	
	Standard	Wear limit
Pump body and inner rotor, outer rotor clearance	0.03 ~ 0.09 (0.0011 ~ 0.0035)	0.13 (0.0051)

- (4) Clearance between rotor shaft and side cover
Measure the rotor shaft outer diameter and the side cover hole diameter, and replace the entire assembly if the clearance exceeds the limit.

	mm (in.)	
	Standard	Wear limit
Rotor shaft and body clearance	0.013 ~ 0.043 (0.0005 ~ 0.0016)	0.2 (0.0078)

- (5) Check for looseness of driver gear/rotor shaft fitting, and replace the entire assembly if loose or wobbly.
- (6) Push the oil pressure regulating valve piston from the oil hole side, and replace the assembly if the piston does not return due to spring breakage, etc.
- (7) Make sure that the rotor shaft rotates smoothly and easily when the drive gear is rotated.

Turning torque	less than 1.5 kg-cm (0.108 ft-lb)
----------------	-----------------------------------

3. Lube Oil Filter

3-1 Lube oil filter construction

The lube oil filter is a full-flow paper element type, mounted to the side of the cylinder body with the filter bracket. It is an easy to remove cartridge type filter.

To prevent seizure in the event of the filter clogging up, a bypass circuit is provided in the oil filter. The bypass valve in the filter element opens when the difference in pressure in front and behind the paper element reaches 0.8 ~ 1.2 kg/cm² (11.38 ~ 17.06 lb/in.²).

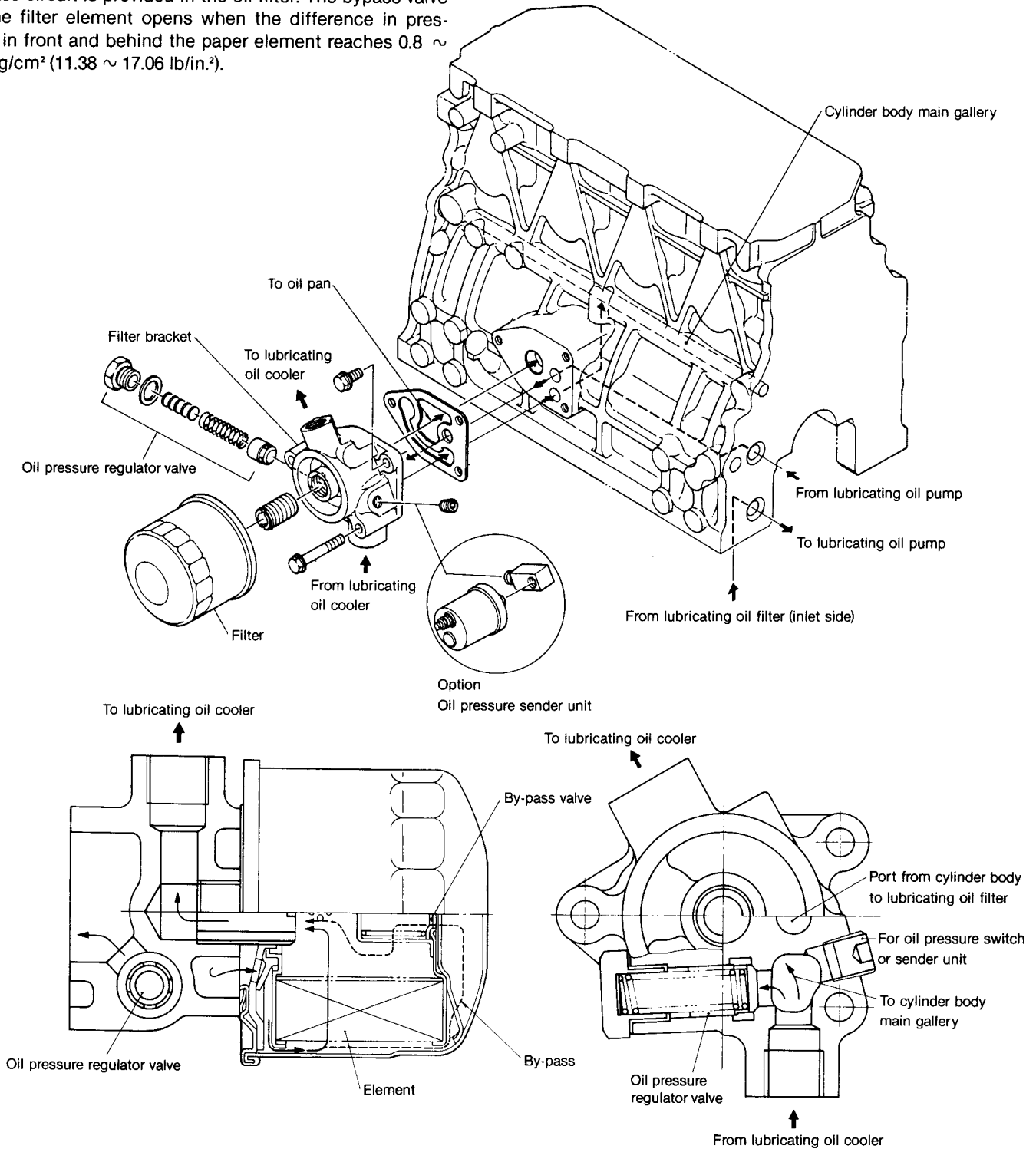

Type	Full flow, paper element
Filtration area	0.10m ² (155 in. ²)
Discharge volume	30 l/min (1830 in. ³ /min)
Pressure loss	0.3 ~ 0.5 kg/cm ² (4.26 ~ 7.11 lb/in. ²)
By-pass valve regulating pressure	0.8 ~ 1.2 kg/cm ² (11.37 ~ 17.06 lb/in. ²)

3-2 Lube oil filter replacement

(1) Period

The paper element will get clogged up with dirt after long hours of usage, and eventually unfiltered oil will be fed to the engine through the bypass circuit. Replace the filter according to the following standard, as the dirt in unfiltered oil will of course have a detrimental affect on the engine.

Oil filter replacement period	Every 300 hours of engine operation
-------------------------------	-------------------------------------

(2) Replacement

- 1) Remove the lube oil filter with the special tool.
- 2) Clean the filter mounting surface on the filter bracket and mounting screws.
- 3) Coat the filter rubber packing with lube oil.
- 4) Screw in the filter until the rubber packing comes in contact with the bracket mounting surface, and then 2 ~ 3 turns more.
- 5) Run the engine after mounting the filter, and make sure that there is no oil leakage.

4. Oil Pressure Control Valve

4-1 Oil pressure control valve construction

The oil pressure control valve built into the oil filter bracket controls the oil pressure from the time the lube oil leaves the filter and is cooled in the lube oil cooler until just before it enters the cylinder body main gallery.

When the pressure of lube oil entering the cylinder body main gallery exceeds the setting, the control valve piston opens the bypass hole and lube oil flows back into the oil pan.

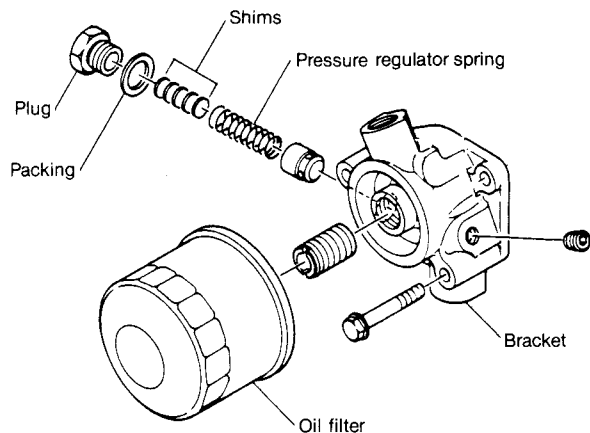

Regulating pressure	3.5 ~ 4.5 kg/cm ² (49.78 ~ 64.00 lb/in. ²)
---------------------	--

4-2 Oil pressure control valve replacement

The control valve has been adjusted and assembled at the factory, so it should not be disassembled without good reason.

If the oil pressure control valve is disassembled due to spring trouble, etc., mount a pressure gauge on the oil pressure sender unit mounting washer, and adjust the pressure with adjustment shims until it is at the specified value.

Shim thickness	Shim part No.
0.2mm (0.0078 in.)	121850-35210
0.5mm (0.0196 in.)	121850-35220
1.0mm (0.0393 in.)	121850-35230

4-3 Vibration preventing damper

The filter bracket hydraulic (oil pressure) sender unit mount is constructed so that a vibration preventing damper can be mounted on it.

The hydraulic sender unit is mounted on the damper.

5. Lube Oil Cooler [Applicable Engine Model 4JHE & 4JH-TE]

5-1 Lube oil cooler construction

The spiral thread of the inner pipe is in contact with the inner surface of the outer pipe. This forms a spiral passageway.

The lube oil flows through this passageway and is cooled by the cooling water (sea water) flowing through the inner pipe.

There are two such pipes, connected side by side, designed so that the lube oil and sea water flow in the opposite directions.

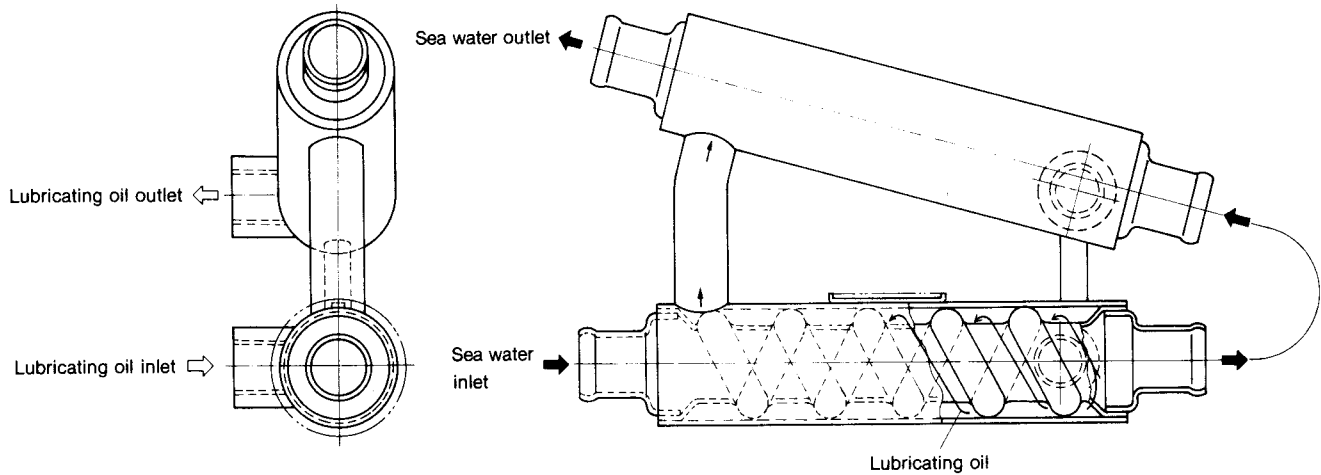

Cooling area	0.0192m ² (29.76 in. ²)
Cooling water discharge volume	3773 l/hr (230228 in. ³ /h)
Lubricating oil discharge volume	2160 l/hr (131803 in. ³ /h)
Lubricating oil temperature at 40°C room air	Model 4JHE: 110°C or below Model 4JH-TE: 115°C or below

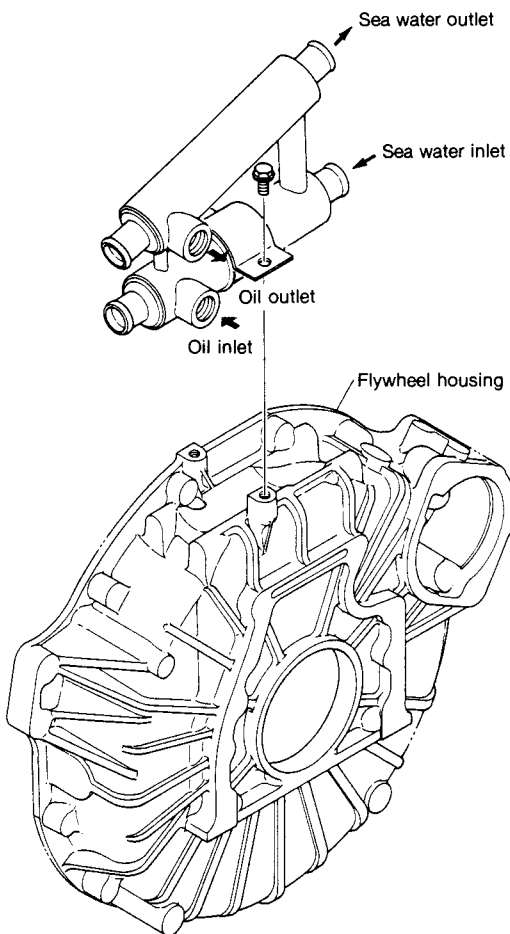

5-2 Inspecting the lube oil cooler

- (1) Clean the inside of the sea water pipes with a wire brush to prevent the build-up of scale.
- (2) If the rubber hose connection or welds are corroded, repair or replace the cooler.
- (3) Apply the following water pressures to the sea water and lube oil lines to check for any leakage. Repair or replace the cooler if there are any leaks.

	Test pressure
Lubricating oil circuit	8 kg/cm ² (113.78 lb/in. ²)
Sea water circuit	4 kg/cm ² (56.89 lb/in. ²)

Lube Oil Cooler [Applicable Engine Model 4JH-HTE & 4JH-DTE]

5-1 Lube oil cooler construction

The lube oil cooler is comprised of 36 cooling pipes and 9 internal baffle plates.

The lube oil flows through this passageway and is cooled by the cooling water (sea water) flowing through the inner pipe.

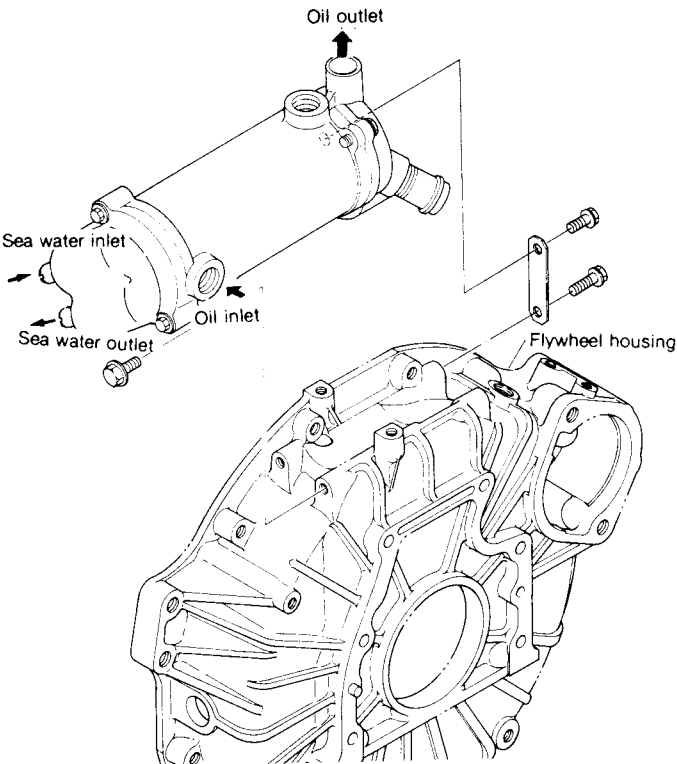
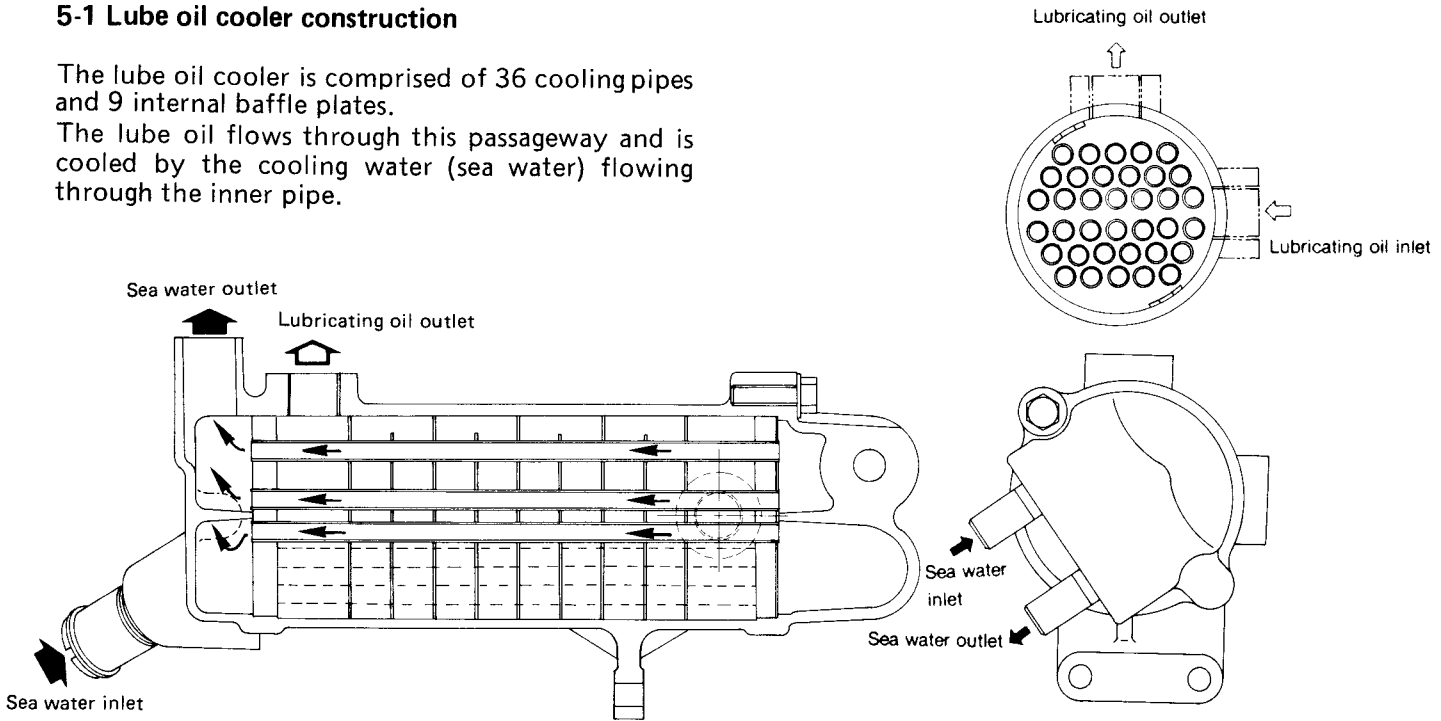

Cooling area	0.165m ² (255.75 in. ²)
Cooling water discharge volume	3500ℓ/hr (213570 in. ³ /h)
Lubricating oil discharge volume	2160 ℓ/hr (131803 in. ³ /h)
Lubricating oil temperature at 40°C room temperature	100°C or below

5-2 Inspecting the lube oil cooler

- (1) Clean the inside of the sea water pipes with a wire brush to prevent the build-up of scale.
- (2) If the rubber hose connection or welds are corroded, repair or replace the cooler.
- (3) Apply the following water pressures to the sea water and lube oil lines to check for any leakage. Repair or replace the cooler if there are any leaks.

	Test pressure
Lubricating oil circuit	15kg/cm ² (213.30 lb/in. ²)
Sea water circuit	4 kg/cm ² (56.89 lb/in. ²)

6. Piston Cooling Nozzle

6-1 Piston cooling nozzle construction

A nozzle made from steel piping is mounted on the lower part of cylinder body main gallery. Lube oil from the main gallery is sprayed out in a jet from the steel tip ($\varnothing 1.77\text{mm}$ (0.0697in.)) of this pipe.

This jet spray cools the piston surface when the piston goes down.

6-2 Inspection of piston cooling nozzle

- (1) Check the nozzle tip hole to see if it is clogged up with dirt or other foreign matter, and clean.
- (2) Inspect the pipe mounting to see if it is or may become loose or come off due to vibration, etc., and replace if necessary.

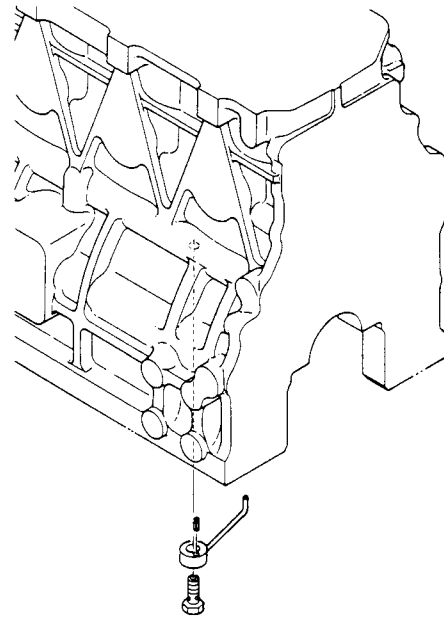
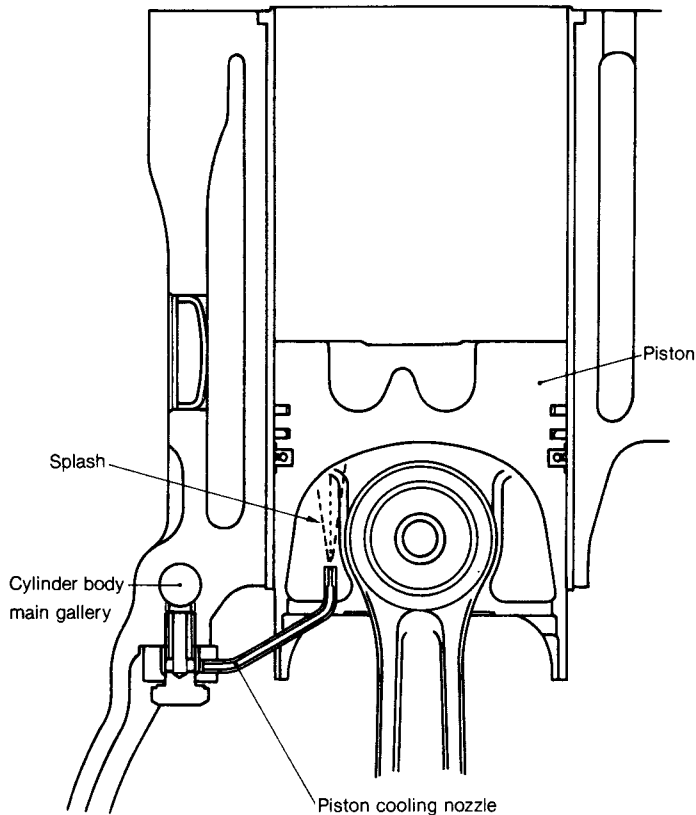

Oil injection volume	1.3 ℓ/min . (79.32 $\text{in.}^3/\text{min}$)
Oil injection pressure	3.5 kg/cm^2 (49.78 $\text{lb}/\text{in.}^2$)

7. Rotary Waste Oil Pump (Optional)

A rotary waste oil pump to pump out waste oil during oil changing is available as an option.

This is a vane type pump. Turning the handle rotates the vanes and pumps out lube oil.

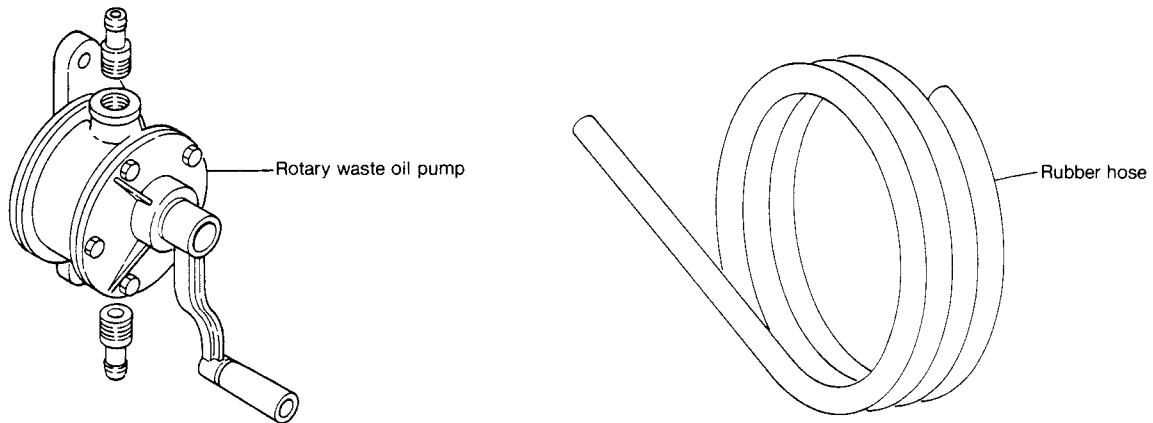

7-1 Construction

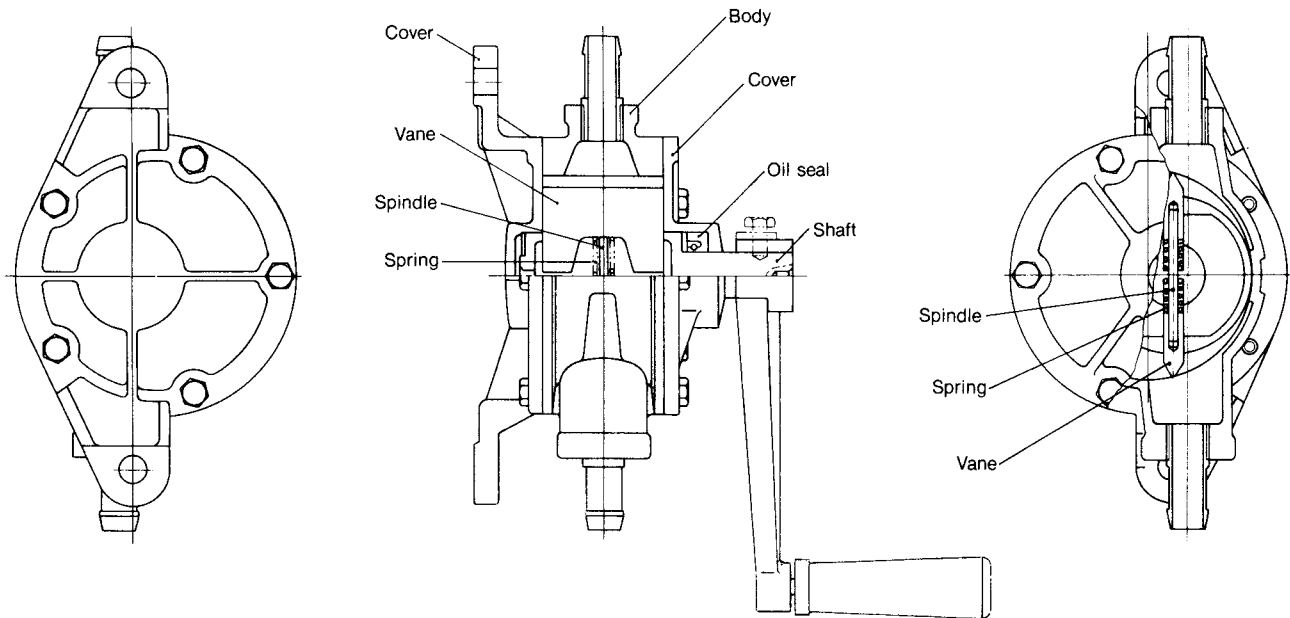

Rotary waste oil pump

Delivery capacity of one stroke	0.13l (7.93 in. ³)
Delivery pressure	1.5 kg/cm ² (21.33 lb/in. ²) or below
Suction head	less than 1m (39.37 in.)
Part No.	43600-002311

Rubber hose

Inner dia. × length	∅12 × 1000mm (0.4724 × 39.37 in.)
Part No. of rubber hose	43720-001220

7-2 Inspecting the waste oil pump

- (1) Disassemble the waste oil pump and check for spring breakage or vane damage when there is an extreme drop in discharge volume, and replace if necessary.
- (2) Replace the oil seal if there is excessive oil leakage from the handle shaft.
- (3) Replace the impeller if there is an excessive gap between the impeller and the covers on both sides of casing. This will cause a drop in discharge volume.
- (4) The hose coupling is coated with adhesive and screwed in. It therefore cannot be disassembled.