

CHAPTER 8

REMOTE CONTROL (OPTIONAL)

<u>1</u>	<u>Remote Control System</u>	<u>8-1</u>
<u>2</u>	<u>Remote Control Installation</u>	<u>8-2</u>
<u>3</u>	<u>Remote Control Inspection</u>	<u>8.5</u>
<u>4</u>	<u>Remote Control Adjustment</u>	<u>8-6</u>

1. Remote Control System

1-1 Construction of remote control system

The remote control permits one handed control of the engine speed, changing from forward to reverse, and stopping.

Fittings which allow for easy connection of the remote control cables with the fuel injection pump and transmission are provided with the remote control set.

The use of Morse remote control cables, clamps and a remote control head, are also provided for. The device to stop the engine is electric and will be explained under the section on electrical equipment.

1-2 Remote control device components

	Morse description	Yanmar Part No.
Remote control head	Morse MT2 top mounting single lever	41730-000680
	Morse MV side mounting single lever	128170-86500
Remote control cable	Morse 33C x 4m (13.12ft.)	41710-000360
	Morse 33C x 7m (23.00ft.)	129470-86500
Engine stop cable	Yanmar 4m (13.12ft)	129470-67550
	Yanmar 7m (22.96ft)	129470-67560

(1) Remote control handle

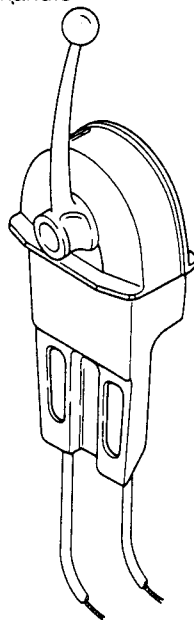

MT-2 Type

The model MT-2 remote control has been designed so that operation of the clutch (shift) and governor (throttle) can be effected with one lever.

Two cables are required for the MT-2 single, one for the clutch and the other for the governor.

When warming up the engine, to freely control the governor separately from the clutch put the lever in neutral, the central position, and pull the knob in the center of the control lever. When the lever is returned to the neutral position, the knob automatically returns to its original position, and the clutch is free. The governor can then be freely operated.

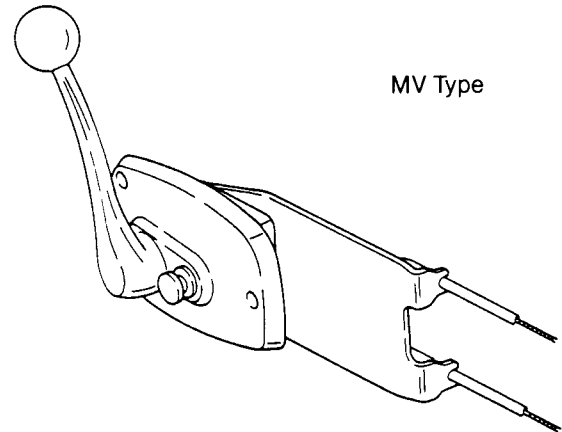

MV Type

The MV type controller has been designed so that operation of the clutch and throttle can be effected with one lever. When the button next to the control lever is pulled out with the lever in the central position, it holds the clutch in the neutral position so that the throttle can be opened all the way and warm up the engine.

When the engine is warmed up, return the handle to the central position and push the button back in. Control of the clutch and throttle is thus effected with one handle.

(2) Remote control cable

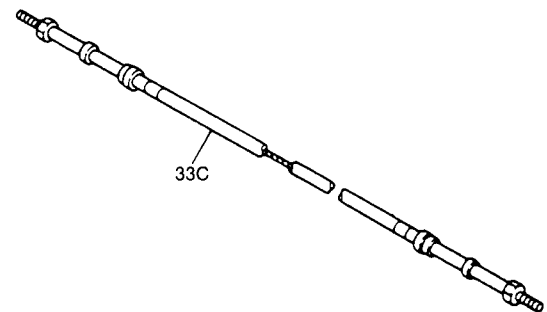

33C

Use only Super-Responsive Morse Control Cables. These are designed specifically for use with Morse control heads. This engineered system of Morse cables, control head and engine connection kits ensures dependable, smooth operation with an absolute minimum of backlash.

(3) Engine stop cable

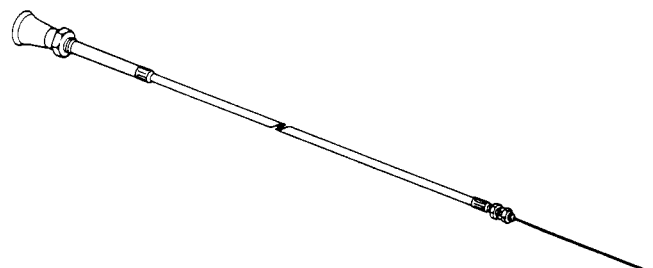

2. Remote Control Installation

2-1 Speed control

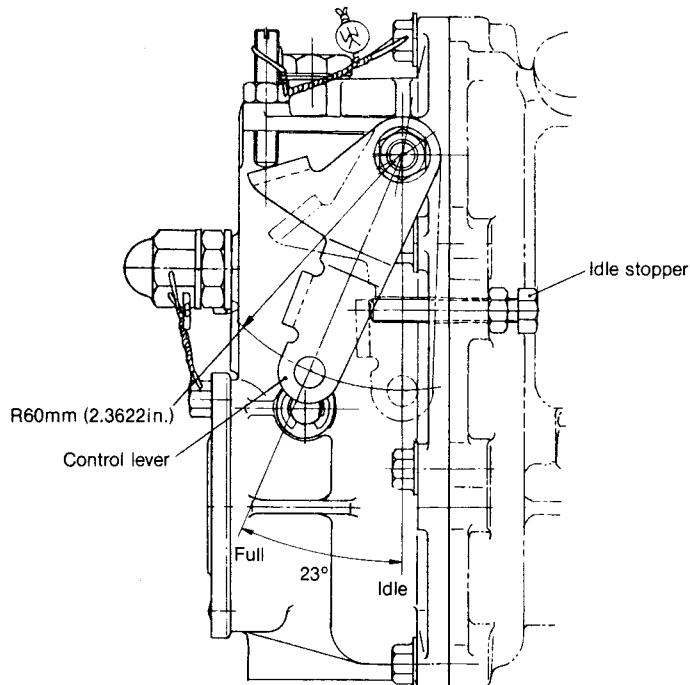
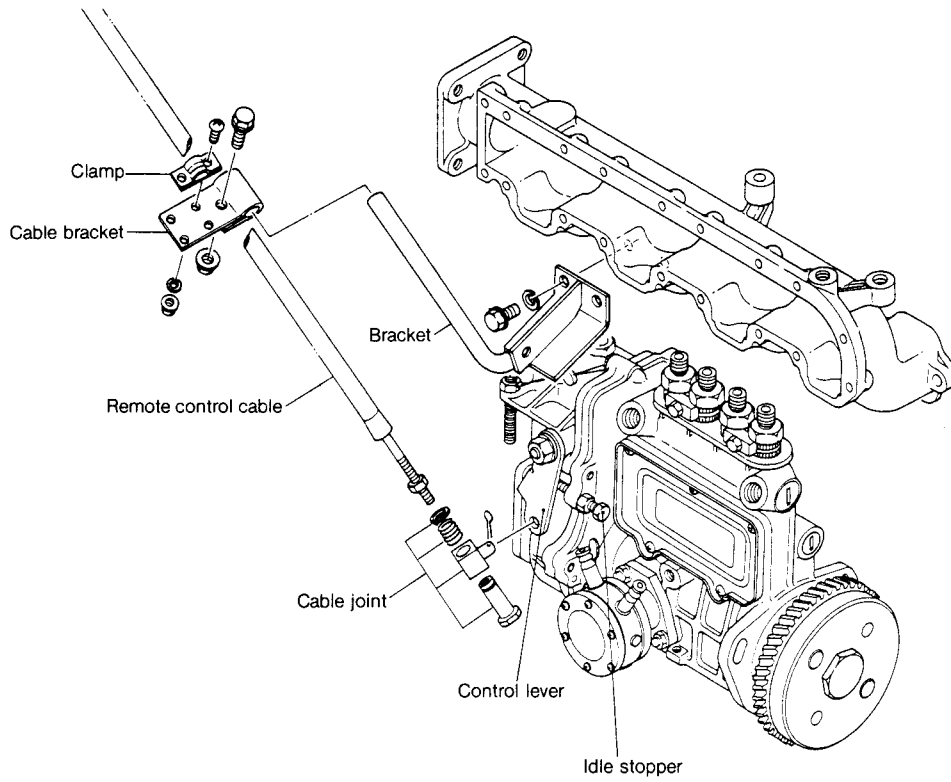

2-2 Clutch control

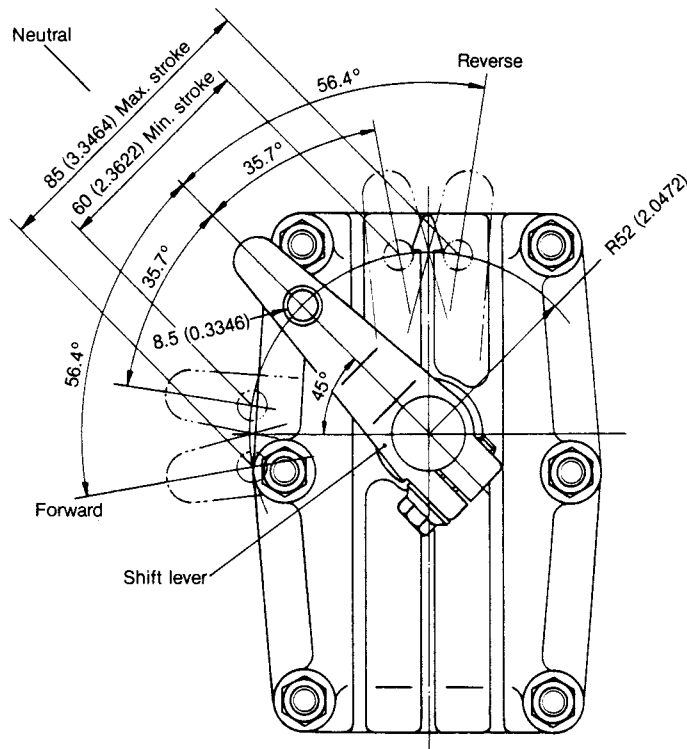
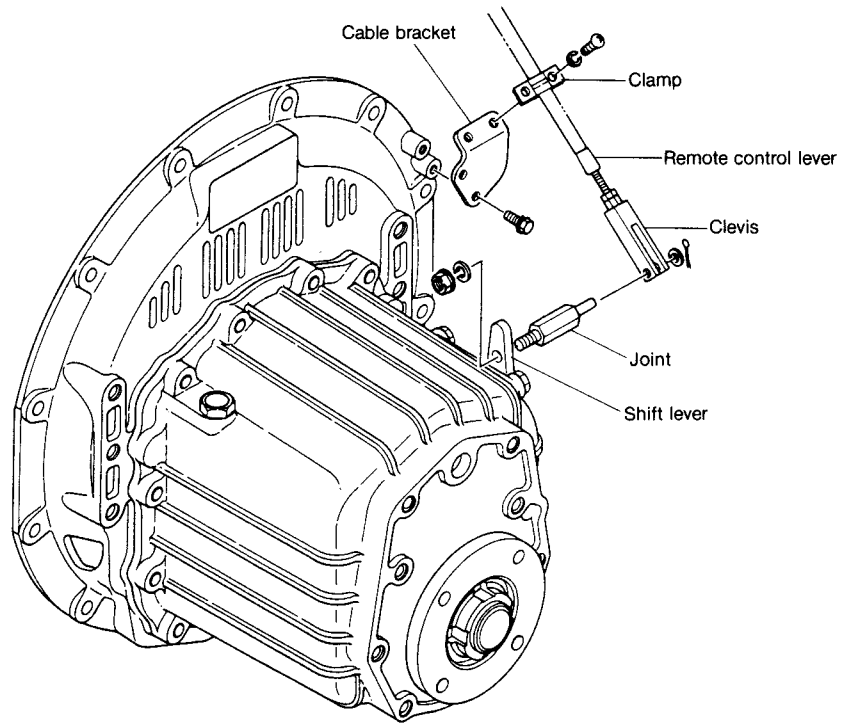

mm (in.)

2-3 Engine stop

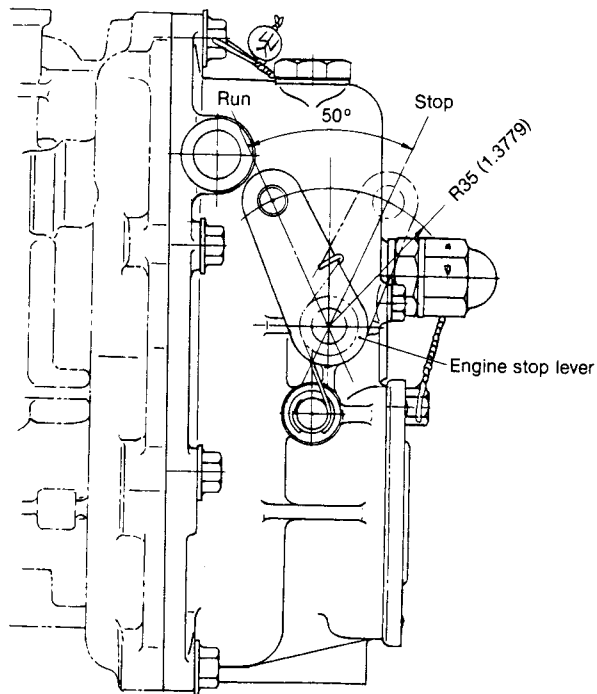
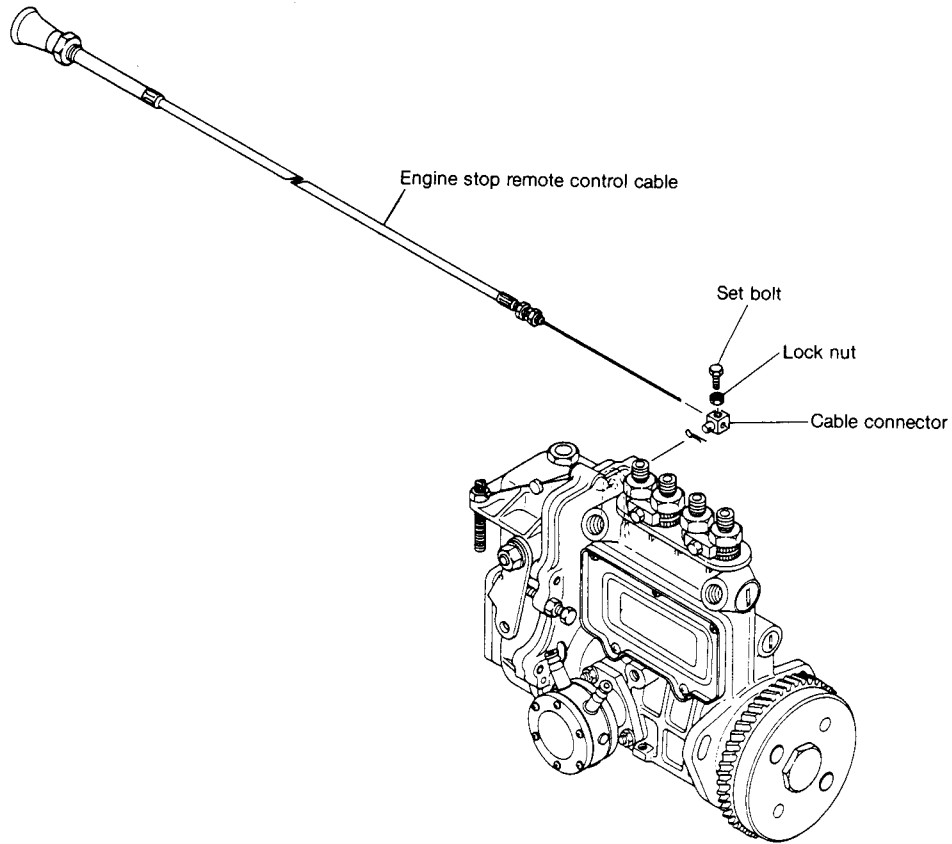

mm (in.)

3. Remote Control Inspection

- (1) When the control lever movement does not coincide with operation of the engine, check the cable end stop nut to see whether or not it is loose, and readjust/ retighten when necessary.

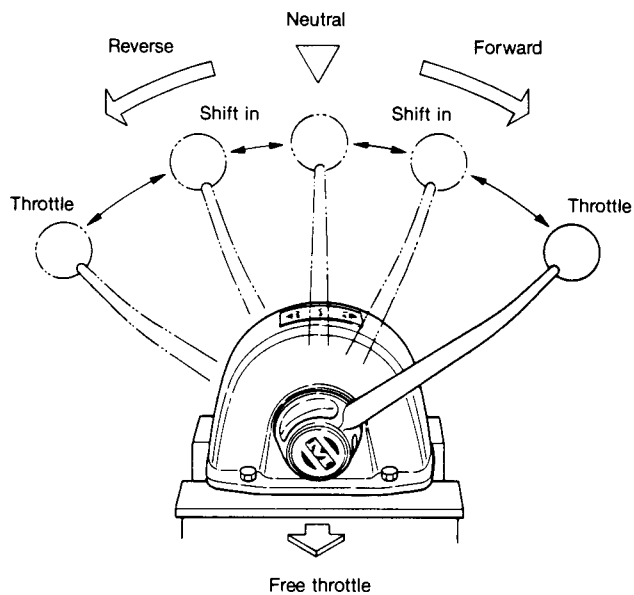

- (2) To many bends (turns) in the cable or bends at too extreme an angle will make it difficult to turn the handle. Reroute the cable to reduce the number of bends or enlarge the bending radius as much as possible (to 200mm or more).
- (3) Check for loose cable bracket/clamp bolts or nuts and retighten as necessary.
- (4) Check cable connection screwheads, cable sleeves and other metal parts for rust or corrosion. Clean off minor rust and wax or grease the parts. Replace if the parts are heavily rusted or corroded.

4. Remote Control Adjustment

(1) Shift lever adjustment

Move the lever several times—the movement of the clutch lever on the engine from forward, neutral and reverse must coincide with the forward, neutral and reverse on the control lever. If they do not coincide, adjust the fittings as necessary (first engine side, then controller side).

(2) Throttle lever adjustment

Move the control lever all the way to full throttle several times, and then return. The throttle lever on the engine must lightly push against the idle switch when it is returned. If it is properly adjusted, the knob can be easily pulled out when the lever is in the neutral position, and will automatically return when the control lever is brought back to the neutral position. If the control lever presses too hard against the knob, it may not return automatically, in which case the cable end must be adjusted as explained for the clutch. The knob cannot be pulled out when the lever is not in the neutral (central) position.

